

XP-30

64 VOICE EXPANDABLE SYNTHESIZER

"Session," "Orchestral" and "Techno Collection" onboard
2x EXPANSION

OWNER'S MANUAL

Thank you, and congratulations on your choice of the Roland XP-30 64 Voice Expandable Synthesizer.

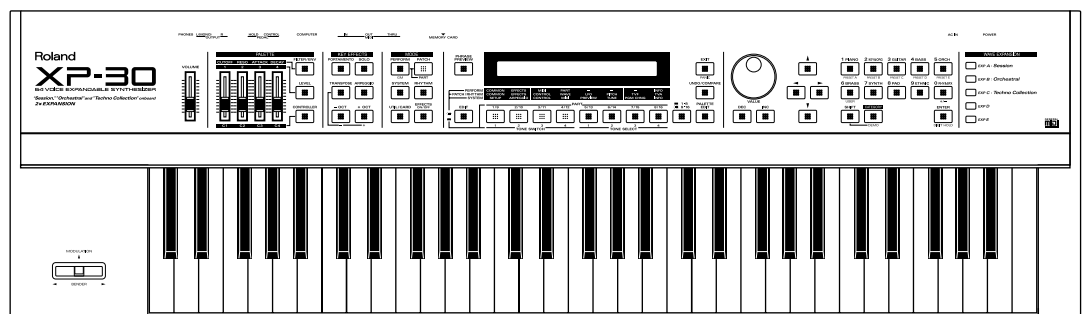

Before using this unit, carefully read the sections entitled: "IMPORTANT SAFETY INSTRUCTIONS" (p. 2), "USING THE UNIT SAFELY" (p. 3), and "IMPORTANT NOTES" (p. 5). These sections provide important information concerning the proper operation of the unit. Additionally, in order to feel assured that you have gained a good grasp of every feature provided by your new unit, Owner's manual should be read in its entirety. The manual should be saved and kept on hand as a convenient reference.



- * Apple is a registered trademark of Apple Computer, Inc.
- * Macintosh is a registered trademark of Apple Computer, Inc.
- * IBM is a registered trademark of International Business Machines Corporation.
- * IBM PC is a registered trademark of International Business Machines Corporation.
- * SmartMedia is a trademark of Toshiba Corporation.

Copyright © 1999 ROLAND CORPORATION

All rights reserved. No part of this publication may be reproduced in any form without the written permission of ROLAND CORPORATION.

	CAUTION RISK OF ELECTRIC SHOCK DO NOT OPEN	
ATTENTION: RISQUE DE CHOC ELECTRIQUE NE PAS OUVRIR		
CAUTION: TO REDUCE THE RISK OF ELECTRIC SHOCK, DO NOT REMOVE COVER (OR BACK). NO USER-SERVICEABLE PARTS INSIDE. REFER SERVICING TO QUALIFIED SERVICE PERSONNEL.		



The lightning flash with arrowhead symbol, within an equilateral triangle, is intended to alert the user to the presence of uninsulated "dangerous voltage" within the product's enclosure that may be of sufficient magnitude to constitute a risk of electric shock to persons.



The exclamation point within an equilateral triangle is intended to alert the user to the presence of important operating and maintenance (servicing) instructions in the literature accompanying the product.

INSTRUCTIONS PERTAINING TO A RISK OF FIRE, ELECTRIC SHOCK, OR INJURY TO PERSONS.

IMPORTANT SAFETY INSTRUCTIONS SAVE THESE INSTRUCTIONS

WARNING - When using electric products, basic precautions should always be followed, including the following:

1. Read these instructions.
2. Keep these instructions.
3. Heed all warnings.
4. Follow all instructions.
5. Do not use this apparatus near water.
6. Clean only with a dry cloth.
7. Do not block any of the ventilation openings. Install in accordance with the manufacturers instructions.
8. Do not install near any heat sources such as radiators, heat registers, stoves, or other apparatus (including amplifiers) that produce heat.
9. Do not defeat the safety purpose of the polarized or grounding-type plug. A polarized plug has two blades with one wider than the other. A grounding type plug has two blades and a third grounding prong. The wide blade or the third prong are provided for your safety. When the provided plug does not fit into your outlet, consult an electrician for replacement of the obsolete outlet.
10. Protect the power cord from being walked on or pinched particularly at plugs, convenience receptacles, and the point where they exit from the apparatus.
11. Only use attachments/accessories specified by the manufacturer.
12. Never use with a cart, stand, tripod, bracket, or table except as specified by the manufacturer, or sold with the apparatus. When a cart is used, use caution when moving the cart/apparatus combination to avoid injury from tip-over.
13. Unplug this apparatus during lightning storms or when unused for long periods of time.
14. Refer all servicing to qualified service personnel. Servicing is required when the apparatus has been damaged in any way, such as power-supply cord or plug is damaged, liquid has been spilled or objects have fallen into the apparatus, the apparatus has been exposed to rain or moisture, does not operate normally, or has been dropped.



For the U.K.

IMPORTANT: THE WIRES IN THIS MAINS LEAD ARE COLOURED IN ACCORDANCE WITH THE FOLLOWING CODE.

BLUE: NEUTRAL
BROWN: LIVE



As the colours of the wires in the mains lead of this apparatus may not correspond with the coloured markings identifying the terminals in your plug, proceed as follows:
The wire which is coloured BLUE must be connected to the terminal which is marked with the letter N or coloured BLACK.
The wire which is coloured BROWN must be connected to the terminal which is marked with the letter L or coloured RED.
Under no circumstances must either of the above wires be connected to the earth terminal of a three pin plug.

CAUTION: Danger of explosion if battery is incorrectly replaced.
Replace only with same or equivalent type.







USING THE UNIT SAFELY

INSTRUCTIONS FOR THE PREVENTION OF FIRE, ELECTRIC SHOCK, OR INJURY TO PERSONS

About  WARNING and  CAUTION Notices

 WARNING	Used for instructions intended to alert the user to the risk of death or severe injury should the unit be used improperly.
 CAUTION	Used for instructions intended to alert the user to the risk of injury or material damage should the unit be used improperly. * Material damage refers to damage or other adverse effects caused with respect to the home and all its furnishings, as well to domestic animals or pets.







About the Symbols





	The  symbol alerts the user to important instructions or warnings. The specific meaning of the symbol is determined by the design contained within the triangle. In the case of the symbol at left, it is used for general cautions, warnings, or alerts to danger.
	The  symbol alerts the user to items that must never be carried out (are forbidden). The specific thing that must not be done is indicated by the design contained within the circle. In the case of the symbol at left, it means that the unit must never be disassembled.
	The  symbol alerts the user to things that must be carried out. The specific thing that must be done is indicated by the design contained within the circle. In the case of the symbol at left, it means that the power-cord plug must be unplugged from the outlet.

ALWAYS OBSERVE THE FOLLOWING

WARNING









WARNING

- Before using this unit, make sure to read the instructions below, and the Owner's Manual. 
- Do not open or perform any internal modifications on the unit. (The only exception would be where this manual provides specific instructions which should be followed in order to put in place user-installable options; see p. 17, 21.) 
- When using the unit with a rack or stand recommended by Roland, the rack or stand must be carefully placed so it is level and sure to remain stable. If not using a rack or stand, you still need to make sure that any location you choose for placing the unit provides a level surface that will properly support the unit, and keep it from wobbling. 
- Use only the attached power-supply cord. 
- Avoid damaging the power cord. Do not bend it excessively, step on it, place heavy objects on it, etc. A damaged cord can easily become a shock or fire hazard. Never use a power cord after it has been damaged. 
- In households with small children, an adult should provide supervision until the child is capable of following all the rules essential for the safe operation of the unit. 
- Protect the unit from strong impact. (Do not drop it!) 

- Do not force the unit's power-supply cord to share an outlet with an unreasonable number of other devices. Be especially careful when using extension cords—the total power used by all devices you have connected to the extension cord's outlet must never exceed the power rating (watts/ amperes) for the extension cord. Excessive loads can cause the insulation on the cord to heat up and eventually melt through. 
- Before using the unit in a foreign country, consult with your retailer, the nearest Roland Service Center, or an authorized Roland distributor, as listed on the "Information" page. 
- Always turn the unit off and unplug the power cord before attempting installation of the circuit board (SR-JV80 series). 
- DO NOT play a CD-ROM disc on a conventional audio CD player. The resulting sound may be of a level that could cause permanent hearing loss. Damage to speakers or other system components may result. 

USING THE UNIT SAFELY

CAUTION

- Always grasp only the plug on the power-supply cord when plugging into, or unplugging from, an outlet or this unit. 
- Try to prevent cords and cables from becoming entangled. Also, all cords and cables should be placed so they are out of the reach of children. 
- Never climb on top of, nor place heavy objects on the unit. 
- Never handle the power cord or its plugs with wet hands when plugging into, or unplugging from, an outlet or this unit. 
- Before moving the unit, disconnect the power plug from the outlet, and pull out all cords from external devices. 
- Before cleaning the unit, turn off the power and unplug the power cord from the outlet. 
- Whenever you suspect the possibility of lightning in your area, pull the plug on the power cord out of the outlet. 
- Install only the specified circuit board(s) (SR-JV80 series). Remove only the specified screws (p. 17, 21). 

Important Notes

In addition to the items listed under “IMPORTANT SAFETY INSTRUCTIONS” and “USING THE UNIT SAFELY” on pages 2 and 3, please read and observe the following:

Power Supply

- Do not use this unit on the same power circuit with any device that will generate line noise (such as an electric motor or variable lighting system).
- Before connecting this unit to other devices, turn off the power to all units. This will help prevent malfunctions and/or damage to speakers or other devices.

Placement

- Using the unit near power amplifiers (or other equipment containing large power transformers) may induce hum. To alleviate the problem, change the orientation of this unit; or move it farther away from the source of interference.
- This device may interfere with radio and television reception. Do not use this device in the vicinity of such receivers.
- Do not expose the unit to direct sunlight, place it near devices that radiate heat, leave it inside an enclosed vehicle, or otherwise subject it to temperature extremes. Excessive heat can deform or discolor the unit.
- To avoid possible breakdown, do not use the unit in a wet area, such as an area exposed to rain or other moisture.

Maintenance

- For everyday cleaning wipe the unit with a soft, dry cloth or one that has been slightly dampened with water. To remove stubborn dirt, use a cloth impregnated with a mild, non-abrasive detergent. Afterwards, be sure to wipe the unit thoroughly with a soft, dry cloth.
- Never use benzine, thinners, alcohol or solvents of any kind, to avoid the possibility of discoloration and/or deformation.

Repairs and Data

- Please be aware that all data contained in the unit’s memory may be lost when the unit is sent for repairs. Important data should always be backed up memory card, or written down on paper (when possible). During repairs, due care is taken to avoid the loss of data. However, in certain cases (such as when circuitry related to memory itself is out of order), we regret that it may not be possible to restore the data, and Roland assumes no liability concerning such loss of data.

Memory Backup

- This unit contains a battery which powers the unit’s memory circuits while the main power is off. When this battery becomes weak, the message shown below will appear in the display. Once you see this message, have the battery replaced with a fresh one as soon as possible to avoid the loss of all data in memory. To have the battery replaced, consult with your retailer, the nearest Roland Service Center, or an authorized Roland distributor, as listed on the “Information” page.

“Battery Low”

Additional Precautions

- Please be aware that the contents of memory can be irretrievably lost as a result of a malfunction, or the improper operation of the unit. To protect yourself against the risk of losing important data, we recommend that you periodically save a backup copy of important data you have stored in the unit’s memory on a memory card.
- Unfortunately, it may be impossible to restore the contents of data that was stored in the unit’s memory, a memory card or another MIDI device (e.g., a sequencer) once it has been lost. Roland Corporation assumes no liability concerning such loss of data.
- Use a reasonable amount of care when using the unit’s buttons, sliders, or other controls; and when using its jacks and connectors. Rough handling can lead to malfunctions.
- Never strike or apply strong pressure to the display.
- When connecting / disconnecting all cables, grasp the connector itself—never pull on the cable. This way you will avoid causing shorts, or damage to the cable’s internal elements.
- A small amount of heat will radiate from the unit during normal operation.
- To avoid disturbing your neighbors, try to keep the unit’s volume at reasonable levels. You may prefer to use headphones, so you do not need to be concerned about those around you (especially when it is late at night).
- When you need to transport the unit, package it in the box (including padding) that it came in, if possible. Otherwise, you will need to use equivalent packaging materials.
- Use only the specified expression pedal (EV-5; sold separately). By connecting any other expression pedals, you risk causing malfunction and/or damage to the unit.

Before Using Memory Cards

Using Memory Cards

- Carefully insert the Memory card all the way in—until it is firmly in place.

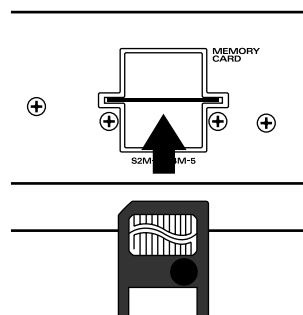

- Never touch the terminals of the Memory card. Also, avoid getting the terminals dirty.

Handling CD-ROMs

- Avoid touching or scratching the shiny underside (encoded surface) of the disc. Damaged or dirty CD-ROM discs may not be read properly. Keep your discs clean using a commercially available CD cleaner.

How to Read This Owner's Manual

This owner's manual is organized as follows.

Quick Start

This section is intended for those using the XP-30 for the first time, and explains how to use various functions in a simple way. Please read **Quick Start** and follow along by actually operating the XP-30. This will help you understand most of what you need to know for basic operations. More advanced ways of using the XP-30 or details of other operations are explained in the **Advanced Use** section.

Advanced Use

The **Advanced Use** section is divided into 6 chapters. But before you start reading it, we'd like to suggest going through the **Quick Start** section.

Chapter 1. Overview of the XP-30

This chapter covers XP-30 sound source section configurations, as well as basic operation. Please be sure to read this chapter in order to fully understand the XP-30.

Chapter 2. Playing

This chapter explains how to use the XP-30 in Patch, Performance and Rhythm Set modes. Reading it is essential for understanding XP-30 operational procedures.

Chapter 3. Creating Your Own Sounds

This chapter covers creating sounds, the parameters that make up a Patch, Performance, or Rhythm Set, and the System parameters that determine global XP-30 operation, as well as their functions. Comprehending the information in the chapter is an essential prerequisite before creating your own sounds.

Chapter 4. Memory Settings (Utility/Card Mode)

This chapter goes over the various Utility functions such as storing Patch, Performance or Rhythm Set data, clearing the internal memory, etc. Being familiar with these will streamline operation procedures.

Chapter 5. Using the XP-30 as the GM Sound Module

This chapter explains needed procedures and parameters for using the XP-30 as a General MIDI System-compatible sound source. Read this chapter before attempting to play back commercial General MIDI System score data.

Chapter 6. Getting the Full Potential of the XP-30

This chapter includes various techniques that expand the XP-30's operational scope. It includes use with external MIDI devices, live performance applications and others.

Appendices

This chapter contains a troubleshooting section for use when the XP-30 is not functioning as expected. There is also a list of error messages that you can refer to if an error message appears on the display. A list of parameters and MIDI implementation chart are also provided.

■ Notation Used in This Owner's Manual

To make operation procedures easy to understand, the following notation system is adopted:

Characters and numbers in square brackets [] indicate buttons on the front panel. For example, [PATCH] represents the PATCH button and [ENTER] the ENTER button.

An asterisk (*) at the beginning of a paragraph indicates a note or precaution. These should not be ignored. In the Quick Start section, such material is indicated by (NOTE).

(p. **) refers to pages within the manual.

In this manual, when any particular parameter is referred to, the name of the parameter is given, and this is then followed (in parenthesis) by information detailing its mode, display group, and display. For example: Key Mode parameter (PERFORM/COMMON/PERFORM COMMON).

* *The display screens printed in this owner's manual are based on the factory settings. However, please be aware that in some cases they may differ from the actual factory settings.*

Contents

Main Features	11
Front and Rear Panel	12
Quick Start	15
Getting Ready	16
Installing the Wave Expansion Board	16
Cautions When Installing an Wave Expansion Board.....	16
Installation de la carte d'extension Wave (French language for Canadian Safety Standard).....	20
Precautions lors de l'installation de la carte d'extension Wave	20
Making Connections	24
Turning On the Power	26
Turning Off the Power	26
Reset to Default Factory Settings (Factory Reset)	27
Listening to the Demo Song	28
Profile of the Composer	29
Playing the Sounds	30
Selecting Patches and Playing the Sounds.....	30
Selecting Wave Expansion Patches	31
Selecting Patches by Category (Patch Search Function)	32
Auditioning the Patches (Phrase Preview)	33
Try Out Performance Functions	34
Velocity/Aftertouch	34
Pitch Bend/Modulation Lever	34
C1-C4 Slider.....	34
Hold Pedal.....	35
Expression Pedal	35
Solo	35
Portamento	35
Sound Palette	36
Play Arpeggios (Arpeggiator)	36
Play Percussion Sounds from the Keyboard	38
Advanced Use	39
Chapter 1. Overview of the XP-30	40
XP-30 Configuration.....	40
Basic Configuration.....	40
Classification of XP-30 Sound Types.....	40
Number of Simultaneous Voices	42
Basic Operation.....	42
Switching Modes.....	42
About the Function Buttons	43
About the Cursor Buttons.....	44
Modifying a Value	45
Assigning a Name.....	46

Chapter 2. Playing.....	47
Playing in Patch Mode.....	47
Selecting a Patch.....	47
Using Phrase Preview to Play Patches.....	49
Making a Patch Sound Thick or Thin (Turning a Tone On/Off).....	50
Playing Single Notes (Solo)	50
Creating Smooth Pitch Changes (Portamento).....	50
Using the Sliders to Modify the Sound in Realtime (Sound Palette Function).....	50
Playing in Performance Mode.....	51
Selecting a Performance	51
Playing Fatter and Richer Sounds by Combining Patches (Layer).....	52
Splitting the Keyboard to Play Separate Patches in Different Sections (Split).....	52
Playing Along with a Song Playback (XP-30 Used as a Multitimbral Sound Source).....	53
Assigning a Different Patch to a Part.....	54
Using the Sliders to Modify the Sound in Realtime (Sound Palette Function).....	54
Playing in Rhythm Set Mode.....	55
Selecting a Rhythm Set.....	55
Playing Percussion Instruments	56
Playing an Arpeggio	56
Playing an Arpeggio Over a Preset Keyboard Area	57
Holding an Arpeggio.....	58
Simulating a Guitar Cutting Technique.....	58
Playing an Arpeggio from an External MIDI Device.....	58
Creating an Arpeggio Pattern	58
Convenient Functions for Performance	59
Transposing the Keyboard in Octave Units (Octave Shift).....	59
Transposing the Keyboard in Semitone Steps (Transpose)	60
If “Stuck” Notes Occur or a Note Does Not Sound (Panic).....	60
 Chapter 3. Creating Your Own Sounds.....	 61
Regarding Effects.....	61
How Effects Units Work in Different Modes.....	61
Turning Effects On/Off.....	62
Sound Editing Procedures.....	62
Editing a Patch.....	62
Editing a Performance	65
Editing a Rhythm Set.....	66
Keeping Edited Sound.....	67
Memory and Data Storage.....	67
Storing a Sound You Modify into User Memory	68
Functions of Patch Parameters	68
Settings Common to the Entire Patch (COMMON).....	68
Setting Effects for a Patch (EFFECTS)	71
Using Controllers to Change How Sounds Are Played (CONTROL).....	73
Modifying Waveform (WAVE).....	76
Modulating Sounds (LFO).....	78
Modifying Pitch (PITCH).....	79
Modifying the Brightness of Sound with a Filter (TVF).....	80
Changing the Sound’s Volume and Stereo Location (TVA)	81
Functions of Performance Parameters.....	83
Settings Common to the Entire Performance (COMMON).....	83
Setting Effects for a Performance (EFFECTS)	84
Making MIDI Settings for a Part (MIDI).....	86
Making Settings for Each Part (PART).....	87
Confirming MIDI Information for Each Part (INFO)	87
Functions of Rhythm Set Parameters	88
Naming a Rhythm Set (COMMON).....	88

Setting Effects for a Rhythm Tone (EFFECTS).....	88
Controlling How a Rhythm Tone will Sound with Controllers (CONTROL)	90
Modifying Waveform of a Rhythm Tone (WAVE).....	90
Modifying Pitch of a Rhythm Tone (PITCH).....	91
Changing the Tone (Filter) of a Rhythm Tone (TVF).....	91
Changing the Volume and Stereo Location of a Rhythm Tone (TVA).....	92
Multi-Effects Types (EFX Parameter)	93
XP-30 Operating Environment Setup (System Parameters and Their Functions).....	108
Display Screen Contrast and Clock Settings (SETUP).....	108
Arpeggio Settings (ARPEGGIO).....	108
Keyboard and Controllers Settings (CONTROL).....	110
MIDI Settings (MIDI).....	112
Phrase Preview Settings (PREVIEW)	113
Adjusting Tuning (TUNE).....	113
Program Change (PGM CHNG).....	114
Checking Things Such as the Installation Status of Wave Expansion Boards (INFO).....	114
Chapter 4. Memory Settings (Utility/Card Mode)	115
About Utility/Card Mode.....	115
Basic Procedure in Utility/Card Mode	115
Storing Sound Data in User Memory (WRITE).....	116
Performance Write	116
Patch Write.....	116
Rhythm Set Write	116
Copying Sound Source Settings (COPY)	117
Performance Copy	117
Patch Copy	117
Rhythm Set Copy	118
Initializing Sound Source Settings (INIT)	119
Performance Initialize.....	119
Patch Initialize	119
Rhythm Set Initialize	119
Transmitting Sound Settings (XFER).....	119
Transmitting Data to an External MIDI Device.....	119
Transmitting Data to User Memory	120
Preventing User Memory Writing Operation (PROTECT)	121
Memory Card-Related Settings (CARD).....	121
Formatting the Memory Card for the XP-30 (FORMAT).....	122
Renaming a File (RENAME).....	122
Deleting Unwanted Files (DELETE).....	122
Checking the Contents Memory Card (INFO).....	122
Loading a File from Memory Card into the XP-30 (LOAD).....	122
Saving Data to Memory Card (SAVE).....	122
Recalling Factory Default Settings (FACTORY RESET)	123
Chapter 5. Using the XP-30 as the GM Sound Module	124
Entering GM Mode.....	124
Initializing the Sound Source for GM System Basic Settings	124
Playing Back a GM Score	124
Modifying GM Mode Settings.....	125
Making Effects Settings in GM Mode (EFFECTS).....	125
Setting a Part (PART).....	127
Confirming MIDI Information of Each Part (INFO)	127
Convenient Functions in GM Mode (GM Utility)	127
Copying Effects Settings (COPY).....	128
Initializing GM Mode (INIT)	128
Transmitting GM Mode Settings (XFER).....	128

Chapter 6. Getting the Full Potential of the XP-30 129

- Techniques for Using Patches..... 129
 - Reinforcing Filter Characteristics 129
 - Making the Up-Beat Note Sound at the Same Time You Play a Down-Beat Note 129
 - Holding a Note with Modulation Retained 129
 - Syncing the LFO Cycle to System Tempo 129
 - Modifying Multi-Effects to Match the System’s Tempo..... 130
 - Using a Pedal Switch to Modify the Rotary Speed of the Rotary Effect 130
 - Playing Phrase Loops at a System’s Tempo 130
 - Using the Slider to Pan Sounds in Real Time 131
- Using the XP-30 to Play Live 131
 - Changing Multiple Sounds of an External MIDI Device Simultaneously 131
 - Changing Sounds with a Pedal Switch..... 131
- Using External MIDI Devices 132
 - Using the XP-30 to Control External MIDI Devices..... 132
 - Playing the XP-30’s Sound Source from an External MIDI Device 132
 - Selecting XP-30 Sounds from an External MIDI Device..... 132
- Enjoying Desktop Music 134
 - Connecting to Your Computer..... 134
 - Disconnecting the Keyboard from the Internal Sound Source (Local OFF) 137

Appendices..... 139

- Troubleshooting..... 140**
- Error Messages 142**
- Quick Reference of Procedures 143**
- Parameter List 147**
- Waveform List 160**
- Patch List..... 168**
- Rhythm Set List..... 177**
- Performance List..... 181**
- Arpeggio Style List 182**
- MIDI Implementation 183**
- Specifications..... 207**
- Computer Cable Wiring Diagrams..... 208**
- Index..... 209**

Main Features

■ High-Performance Synthesizer Sound Source

64-Voice Polyphony and 16-Part Multitimbrality

The XP-30 is a 16-part multitimbral sound source that produces up to 64 simultaneous polyphonic notes. Effectively used with an external sequencer or computer, the XP-30's true creative potential for music production becomes apparent (p. 41).

Powerful Onboard Effects

Advanced DSP (Digital Signal Processor) technology provides a wide array of studio quality effects. In addition to the Multi-Effects (EFX) section that features 40 different types of effects, the XP-30 also features an independent chorus unit and reverb unit (p. 61).

Extensive Tone Structure Range

Ten different Structures are available for combining basic sound elements for more flexible sound making. A ring modulator and booster enhance creating sounds (p. 70).

An Array of Arpeggio and Cutting Options

With the [ARPEGGIO] on, you can create various arpeggios and simulate cutting techniques simply by pressing a chord. You can even specify the rhythmical "feel" you want (p. 56).

General MIDI System Compatibility

The XP-30 provides a mode compatible with the General MIDI System, the standard format for desktop music (DTM) systems, and can play back commercially available General MIDI System compatible song data (p. 124).

General MIDI System

The General MIDI system is a set of recommendations which seeks to provide a way to go beyond the limitations of proprietary designs, and standardize the MIDI capabilities of sound generating devices. Sound generating devices and music files that meets the General MIDI standard bears the General MIDI logo () . Music files bearing the General MIDI logo can be played back using any General MIDI sound generating unit to produce essentially the same musical performance.

■ Expandability

Allows Two Wave Expansion Boards to be Installed at the Same Time

Up to two SR-JV80 series Wave Expansion Boards can be installed simultaneously, allowing you to expand the range of available sounds (p. 16, 20).

Data from Popular Wave Expansion Boards Already Onboard

The data of the three popular Wave Expansion Boards, the SR-JV80-02 "Orchestral," SR-JV80-09 "Session," and SR-JV80-11 "Techno Collection" is onboard.

This means that for practical purposes, you can have simultaneous access to the sounds of up to five Wave Expansion Boards, and can draw on a vast quantity of waveform data as material for creating your sounds.

■ Quick and Intuitive Operation

Enhanced Operational Ease

Dedicated buttons are provided for each function to simplify operation. The group of function buttons located below the display allow intuitive editing (p. 43).

Featuring the Patch Search and Phrase Preview Functions that were Popular on the JV-2080

The Patch Search function (p. 32, 48) lets you rapidly find the patch you want simply by specifying a patch category. By pressing [PHRASE PREVIEW], you can then hear the selected patch play a phrase suitable for that type of patch. (Phrase Preview function, p. 33, 49)

Use the Sound Palette Sliders to Make Quick Changes in the Sound

The four sliders in the PALETTE section let you make realtime changes in tone and volume while you play (p. 36, 50, 54).

■ Computer Interface Connector

A special computer cable makes it easy for you to connect the XP-30 to your computer, so that you can enjoy ensemble playing (p. 134).

Front and Rear Panel

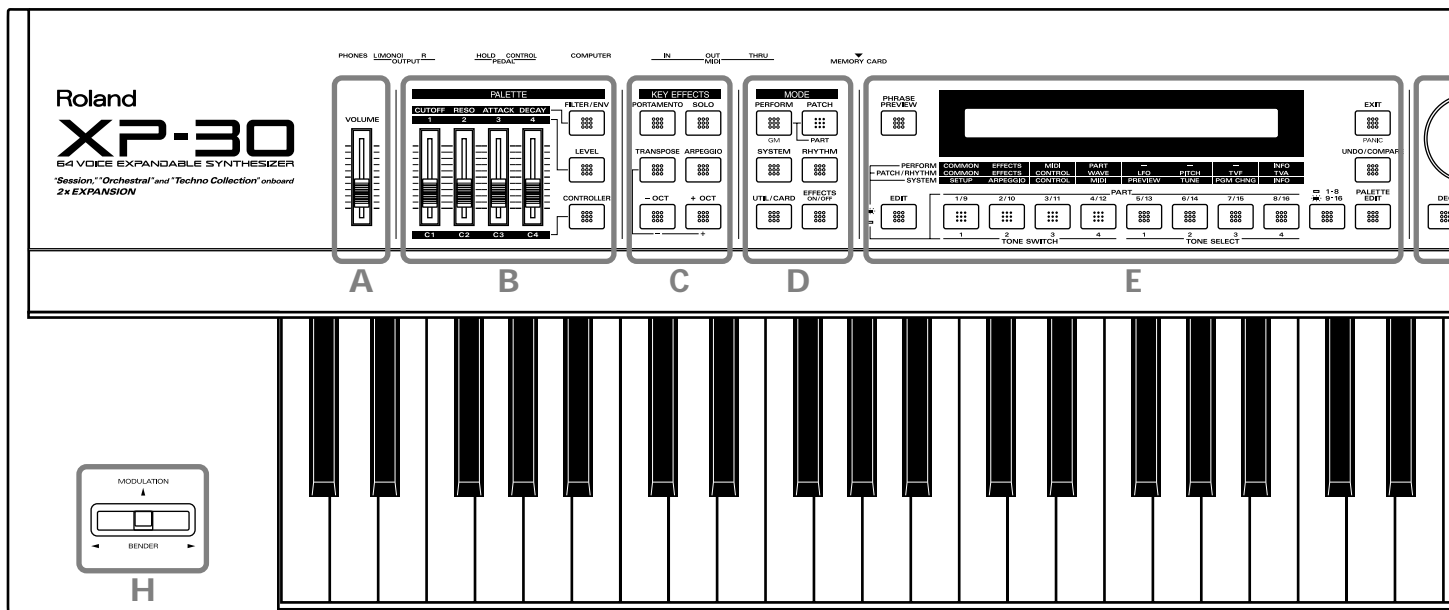

■ Front Panel

A

Volume Slider

This slider adjusts the overall volume that is output from the rear panel OUTPUT jacks and PHONES jack. →p. 26

B PALETTE Section

Use the four sliders to modify sounds in real time.

[FILTER/ENV]

Press this button ON when modifying filter and/or envelope settings in real time using the four sliders (CUTOFF/RESO./ATTACK/DECAY). →p. 36, 51, 54

[LEVEL]

Press this button ON when adjusting volume balance in real time using the four sliders (1/2/3/4). →p. 36, 51, 54

[CONTROLLER]

Can be switched on when you wish to assign various parameters to the four sliders, and modify the sound as you play (C1/C2/C3/C4). →p. 34

C KEY EFFECTS Section

The buttons in this section allow you to assign various functions to the keys of the XP-30's keyboard.

[PORTAMENTO]

Switches Portamento on/off. →p. 35, 50

[SOLO]

Specifies playing a single note at a time. →p. 35, 50

[TRANSPOSE]

Specifies transposing the keyboard in semitone steps. →p. 60

[ARPEGGIO]

Switches Arpeggiator on/off. →p. 36, 56

[+OCT], [-OCT]

These buttons adjust the pitch of the keyboard in octave steps. →p. 59
Pressing either of these buttons while holding down [TRANSPOSE] allows you to set the desired amount of transposition. →p. 60

D MODE Section

The buttons in this section select modes. The button indicator of the selected mode will light. →p. 42

[PERFORM]/[GM]

Pressed to get into Performance mode. Hold down [SHIFT] while you press [PERFORM] to select GM mode. →p. 51, 124

[PATCH]/[PART]

Pressed to get into Patch mode. By holding down [PERFORM] and pressing [PATCH], you can modify the settings of the patch that is assigned to each part of the performance. →p. 47, 54, 66

[SYSTEM]

This selects System mode. →p. 108

[RHYTHM]

This selects Rhythm Set mode. →p. 55

[UTIL/CARD]

This selects Utility/Card mode. →p. 115

[EFFECTS ON/OFF]

This button turns the internal effects (Multi-Effects, Chorus, Reverb) on/off. →p. 62

E

Display

Shows various information for the currently selected function or operation.

[PHRASE PREVIEW]

Press this when you wish to use phrases to audition a patch. →p. 33, 49

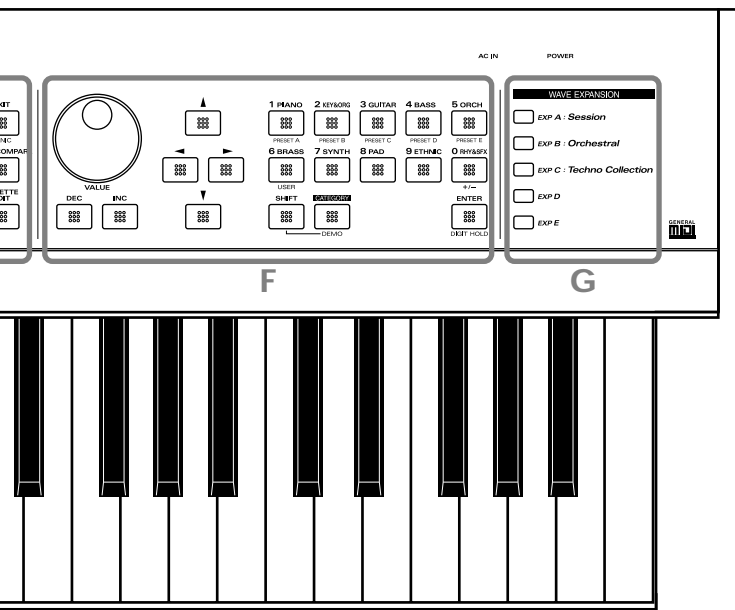

[EDIT]

Press this button when you wish to adjust various settings. Use the function buttons to select the display screen for the parameter you wish to modify.

Function Buttons

The function of these buttons will depend on the operational mode and the status of the [EDIT] indicator. →p. 43

[1-8/9-16]

Use this button to select the group (1-8/9-16) of Parts to be selected by the function buttons. →p. 43

[EXIT]/[PANIC]

EXIT: Press this button when you wish to return to the Play display of a mode, or to cancel an operation without executing.

PANIC: If for some reason notes are stuck and continue sounding, hold down the SHIFT button and press this button to clear the stuck notes. →p. 60

[UNDO/COMPARE]

The function of these buttons will depend on the operation being performed.

UNDO: Press this button to restore a modified value to the original value. →p. 63, 65, 66

COMPARE: When saving or copying Tone settings, press this to check the sound at the save destination, or at the copy source. →p. 116, 118

[PALETTE EDIT]

Press this button when you wish to use the Palette display to modify Patch or Performance settings. →p. 63, 65

F

VALUE Dial

This dial is used to modify values. If you hold down [SHIFT] as you turn the VALUE dial, the value will change in greater increments. →p. 45

[INC], [DEC]

Use these buttons to modify values. If you keep on holding down one button and pressing the other, the value change accelerates. If you press one of these buttons while holding down [SHIFT], the value will change in bigger increments. →p. 45

[◀], [▶] (Cursor Buttons)

Move the cursor (underline) with these.

[▲], [▼] (Page Buttons)

When the left edge of the display shows a ⏏ or ⏏ symbol, use these buttons to move to other parameter displays

[0]-[9] (Numeric Keys)

Use these to set a value. They can be used to enter numeric values as well as alphabetical characters. →p. 45

When [CATEGORY] is on, this becomes the button for choosing a category group using the Patch Search function. →p. 32, 48

[SHIFT]

This is used in combination with other buttons. Some buttons on the front panel include grey-printed characters. They indicate the button's function when [SHIFT] is held down.

[ENTER]/[DIGIT HOLD]

ENTER: Use this button to finalize a value or execute an operation.

DIGIT HOLD: Press this button while holding down [SHIFT] to turn the Digit Hold function on/off. With the Digit Hold on, the 100's place and 10's place will be fixed and only the 1's place will change.

This means that you can select Patches simply by pressing the numeric key for the 1's place, without having to press [ENTER]. The same applies when selecting Performances or Rhythm set. →p. 48

[CATEGORY]/[DEMO]

CATEGORY: Use the Patch Search function to select a patch. →p. 32, 48

DEMO: To hear the demo playback, hold down [SHIFT] and press this button. →p. 28

G WAVE EXPANSION Section

Here you can select sounds from a Wave Expansion. →p. 31

[EXP A], [EXP B], [EXP C]

Select sounds from the internal Wave Expansion.

EXP-A: "Session"

EXP-B: "Orchestral"

EXP-C: "Techno Collection"

[EXP D], [EXP E]

Select sounds from the Wave Expansion Board slots (EXP-D and E).

H

Pitch Bend/Modulation Lever

This allows you to control pitch bend or apply vibrato.

Depending on the settings, other specified parameters can also be controlled. →p. 34, 75

Front and Rear Panel

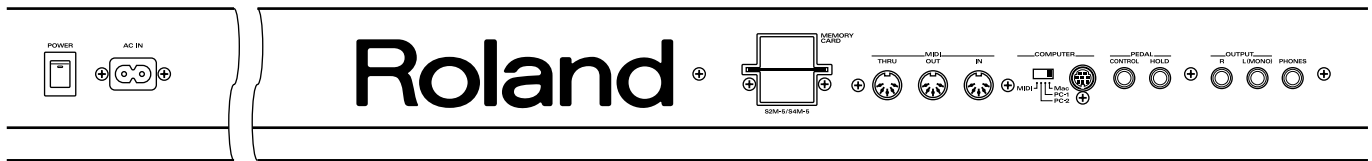

■ Rear Panel

Power Switch

Press to turn the power on/off. →p. 26

AC Inlet

Connect the AC power cable (included) to this inlet. →p. 24

* With units rated for 117V operation, the AC cable is already connected to the unit.

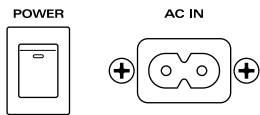

MEMORY CARD Slot

An optional memory card (SmartMedia) can be inserted here.

→p. 115

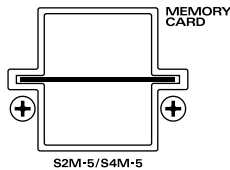

MIDI Connectors (IN, OUT, THRU)

These connectors can be connected to other MIDI devices to receive and transmit MIDI messages. →p. 24, 119, 132

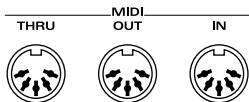

COMPUTER Switch

Set this switch depending on the type of computer connected to Computer connector, or the software you are using. Turn the power off before changing the setting of this switch. If you wish to use the MIDI connectors, set this switch to MIDI.

→p. 134

COMPUTER Connector

A special Computer cable (sold separately) can be connected here. The type of cable required will depend on your computer. When the Computer switch located at the left is set to MIDI, this connector cannot be used. →p. 134

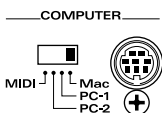

CONTROL PEDAL Jack

You can connect optional expression pedals to these jacks. By assigning a desired function to a pedal, you can use it to select or modify sound or perform various other control. You can also connect optional pedal switches to sustain sound. →p. 24, 110

HOLD PEDAL Jack

An optional pedal switch can be connected to this jack for use as a hold pedal. →p. 24, 110

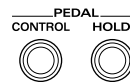

OUTPUT Jacks (L (MONO), R)

These jacks output the audio signal to the connected mixer/amplifier system in stereo. For mono output, use the L jack. →p. 24

PHONES Jack

An optional set of headphones can be connected to this jack. →p. 24



XP-30

64 VOICE EXPANDABLE SYNTHESIZER

*"Session," "Orchestral" and "Techno Collection" onboard
2x EXPANSION*

Quick Start

Getting Ready

Installing the Wave Expansion Board

Up to two Wave Expansion Boards (SR-JV80 series; sold separately) can be installed in EXP-D and E Slots in the XP-30. Wave Expansion Boards contain Wave data, as well as Patches and Rhythm Sets that use this Wave data, which can be called directly into the temporary area and played.

■ Cautions When Installing an Wave Expansion Board

- To avoid the risk of damage to internal components that can be caused by static electricity, please carefully observe the following whenever you handle the board.
 - Before you touch the board, always first grasp a metal object (such as a water pipe), so you are sure that any static electricity you might have been carrying has been discharged.
 - When handling the board, grasp it only by its edges. Avoid touching any of the electronic components or connectors.
 - Save the bag in which the board was originally shipped, and put the board back into it whenever you need to store or transport it.
- Use a Philips screwdriver that is suitable for the size of the screw (a number 2 screwdriver). If an unsuitable screwdriver is used, the head of the screw may be stripped.
- To remove a screw, rotate the screwdriver counter-clockwise. To tighten a screw, rotate the screwdriver clockwise.
- When installing Wave Expansion Boards, remove only the specified screws.
- Be careful that the screws you remove do not drop into the interior of the XP-30.
- Do not leave the bottom cover in a detached state. Be sure to reattach it after the Wave Expansion Boards have been installed.
- Do not touch any of the printed circuit pathways or connection terminals.
- Be careful not to cut your hand on the edge of the installation bay.
- Never use excessive force when installing a circuit board. If it doesn't fit properly on the first attempt, remove the board and try again.
- When circuit board installation is complete, double-check your work.

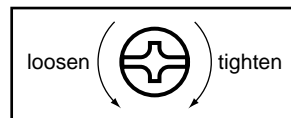

To install an optional Wave Expansion Board (SR-JV80 series; sold separately), the unit's bottom cover must be removed. There are two slots (EXP-D and E) into which a board can be installed. Slots EXP-D and E correspond to the group (XP-D and E) you need to select in order to use a Wave, Patch or Rhythm Set from the Wave Expansion Board.

NOTE

When playing a Patch or Rhythm Set that use the Wave data from a Wave Expansion Board, the appropriate Wave Expansion Board must be installed in the XP-30 for the sound to play correctly.



NOTE
If the same type of Wave Expansion Board is installed in the EXP-D slot and the EXP-E slot, it will only be possible to select data from the Wave Expansion Board that was installed in the EXP-D slot. Also, the XP-30 already contains the data of the following three Wave Expansion Boards, so if one of these Wave Expansion Boards is installed, only the internal data (XP-A-C) can be selected.

SR-JV80-09 "Session" (XP-A)

SR-JV80-02 "Orchestral" (XP-B)

SR-JV80-11 "Techno Collection" (XP-C)

1

Before installing the Wave Expansion Board, turn off the power of the XP-30 and all connected devices, and disconnect all cables from the XP-30.

2

Turn the XP-30 on its back, and remove only the screws shown in the following diagram.

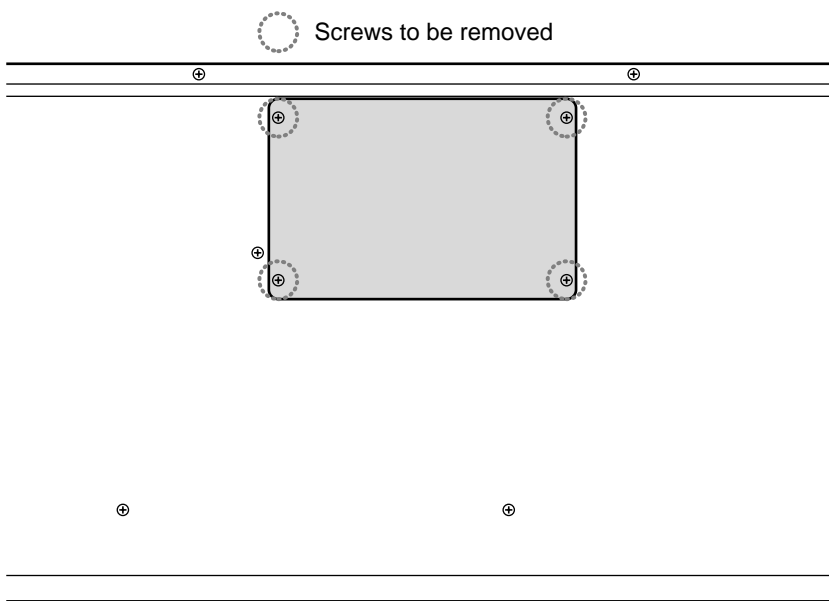

3

Inside, there are two connectors and six board holders. Insert the connectors of the Wave Expansion Board into the internal connectors, and simultaneously insert the board holders into the holes of the Wave Expansion Board.

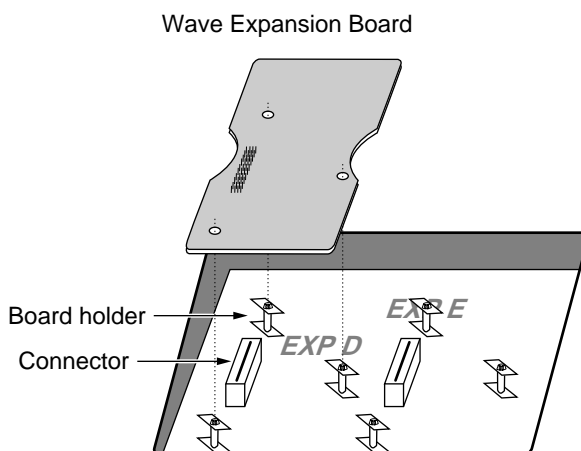

Getting Ready

- 4** Use the Installation Tool supplied with the Wave Expansion Board to turn the holders in the LOCK direction, so the board will be fastened in place.

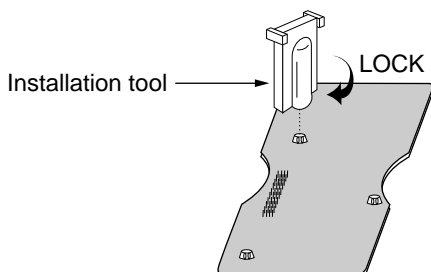

- 5** Use the screws that you removed in step 2 to fasten the cover back in place.

This completes installation of the Wave Expansion Board.

- 6** Connect the cables that you disconnected earlier.

- 7** Turn on the power, as described in “Turning On the Power” (p. 26).

- 8** Press [PATCH] to access the PATCH PLAY display.

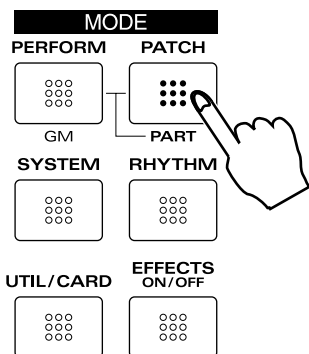

```
PATCH   USER:001 Temple of XP
PLAY                                center=C 4
```

9

Press [EXP D] or [EXP E], and verify that you can select patches from Wave Expansion Boards D or E. [EXP D] or [EXP E] indicator will light, and the following display will appear.

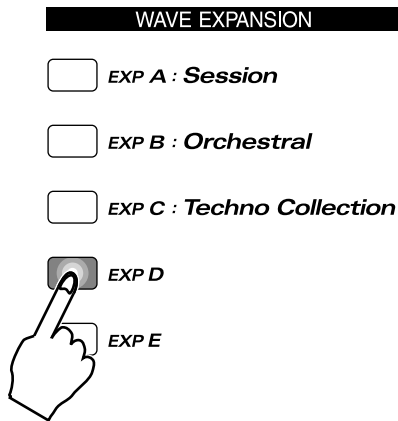

```
PATCH   XP-D:001 Full Scat Sw
PLAY   [Vocal]                center=C 4
```

MEMO

The example here depicts what you would see if the SR-JV80-13 “Vocal Collection” Wave Expansion Board were installed in the EXP-D slot.

NOTE

If you can't choose any Wave Expansion Board patches, it's possible that the installed Wave Expansion Board is not being recognized correctly. Turn off the power as described in “**Turning Off the Power**” (p. 26), and re-install the Wave Expansion Board correctly.

Installation de la carte d'extension Wave (French language for Canadian Safety Standard)

Vous pouvez installer jusqu'à 2 cartes d'extension Wave (en option dans la série SR-JV80) dans les créneaux EXP-D et E du XP-30. Les cartes d'extension Wave contiennent des données Wave, aussi bien que des morceaux musicaux et des ensembles rythmiques utilisant ces données, auxquelles on peut directement accéder dans la zone temporaire et les faire jouer.

■ Précautions lors de l'installation de la carte d'extension Wave

- Pour éviter tout dommage des composants internes pouvant provenir de l'électricité statique, veuillez suivre les conseils suivants quand vous installez la carte.
 - Avant de toucher la carte, saisissez toujours un objet métallique (tuyau d'eau ou autre) pour être sûr que l'électricité statique se décharge.
 - Quand vous saisissez la carte, prenez-la par les bords. Évitez de toucher les composants électroniques ou les connecteurs.
 - Conservez le sac dans lequel la carte était emballée et remettez la carte dedans pour l'expédier ou l'entreposer.
- Utiliser un tournevis cruciforme correspondant à la taille de la vis (un tournevis numéro 2). En cas d'utilisation d'un tournevis inapproprié, la tête de la vis pourrait être endommagée.
- Pour enlever les vis, tourner le tournevis dans le sens contraire des aiguilles d'une montre. Pour resserrer, tourner dans le sens des aiguilles d'une montre.
- Lors de l'insertion de la carte d'extension Wave, enlevez seulement les vis indiquées dans les instructions.
- Veillez à ne pas laisser tomber de vis dans le châssis du XP-30.
- Ne pas laisser le panneau de protection avant détaché. S'assurer de l'avoir rattacher après avoir installé le disque dur.
- Ne touchez aucun des circuits imprimés ni les bornes de connexion.
- Veillez à ne pas vous couper les doigts sur le bord de l'ouverture d'installation.
- Ne jamais forcer quand vous installez une carte de circuits. Si la carte ne rentre pas correctement, ressortez-la et ressayer.
- Quand la carte est installée, vérifiez si l'installation est correcte.

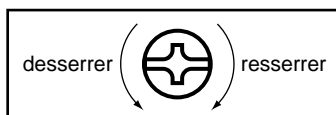

Pour installer une carte d'extension Wave optionnelle (série SR-JV80), le panneau du bas de l'appareil doit être enlevé. Vous trouverez 2 créneaux (EXP-D et E) dans lesquels vous pourrez installer une carte. Les créneaux EXP-D et E correspondent au groupe (XP-D et E) que vous devez sélectionner pour pouvoir utiliser une donnée Wave, un morceau musical ou un ensemble rythmique de la carte d'extension.



Quand vous faites jouer un morceau ou un ensemble rythmique qui utilise des données Wave de la carte d'extension, une carte d'extension appropriée doit être installée dans le XP-30 afin que le son sorte correctement.

NOTE

Si la même sorte de carte d'extension Wave est installée dans les créneaux EXP-D et EXP-E, il ne sera possible de sélectionner que les données de la carte d'extension Wave installée dans le créneau EXP-D. De plus, le XP-30 contient déjà les données des 3 cartes d'extension Wave suivantes si bien que si une de ces 3 cartes est installée, seules les données internes (XP-A-C) pourront être sélectionnées.

SR-JV80-09 "Session" (XP-A)

SR-JV80-02 "Orchestral" (XP-B)

SR-JV80-11 "Techno Collection" (XP-C)

1 Éteindre le XP-30 et tous les appareils qui y sont reliés et débrancher tous les câbles du XP-30.

2 Retournez le XP-30 et enlevez seulement les vis indiquées sur la figure.

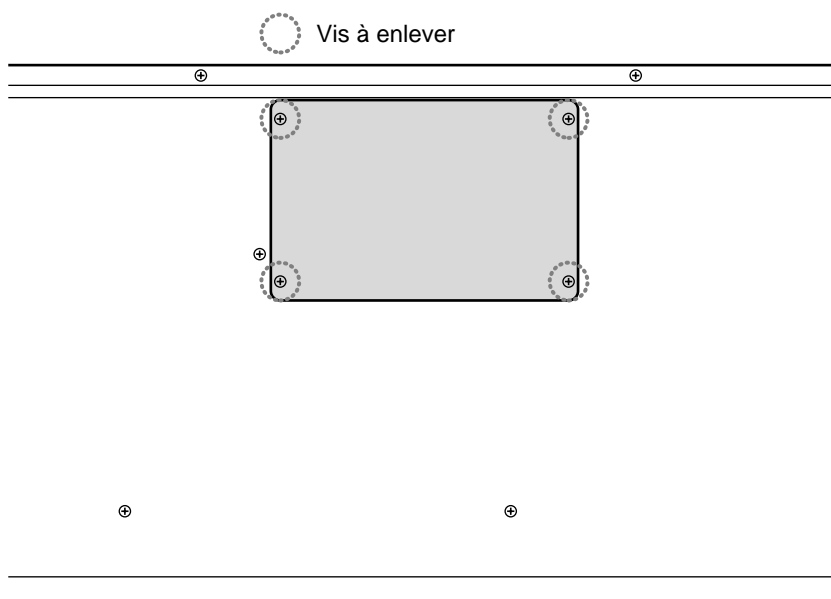

3 À l'intérieur, il y a 2 connecteurs et 6 supports à carte. Insérer les connecteurs de la carte d'extension Wave dans les connecteurs internes tout en insérant simultanément les supports à carte dans les trous de celle-ci.

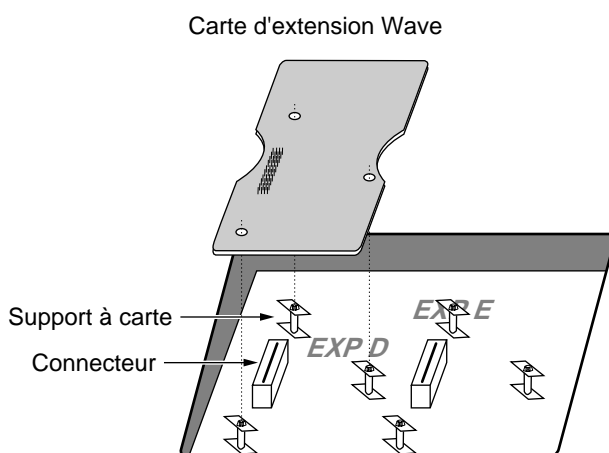

Getting Ready

French language
for Canadian Safety Standard

- 4** Pour tourner les supports en position LOCK (verrouillé), utilisez l'outil d'installation de la carte d'extension fournie à cet effet. De cette façon, la carte sera bien fixée à sa place.

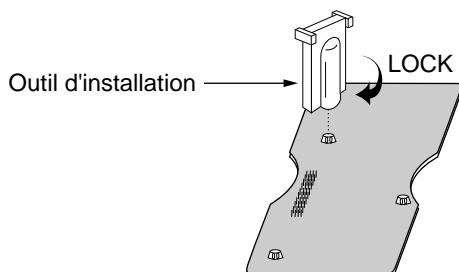

- 5** Reposez le couvercle en remettant les vis enlevées (comme spécifié) à l'étape 2.

L'installation de la carte d'extension Wave est terminée.

- 6** Rabranchez les câbles.

- 7** Mettez le XP-30 sous tension en procédant comme indiqué dans "Turning On the Power" (p. 26).

- 8** Appuyer sur [PATCH] pour accéder à la page PATCH PLAY.

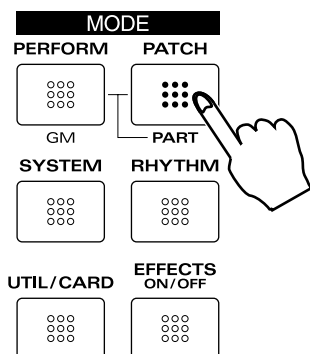

```
PATCH    USER:001 Temple of XP
PLAY    center=C 4
```

9

Appuyer sur [EXP D] ou [EXP E] et vérifier si vous pouvez sélectionner les morceaux musicaux des cartes d'extension Wave D ou E. L'indicateur [EXP D] ou [EXP E] s'allumera et l'affichage suivant apparaîtra.

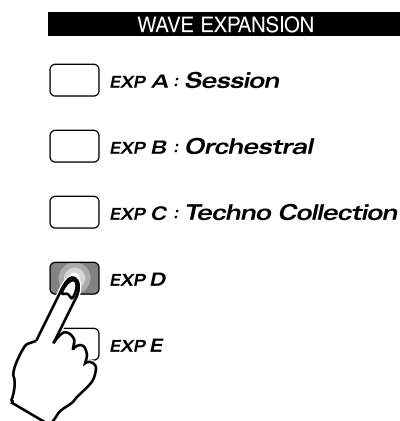

```
PATCH      XP-D:001 Full Scat Sw
PLAY      [Vocal]                center=C 4
```

MEMO

Ceci est un exemple d'affichage lorsque la carte d'extension Wave SR-JV80-13 "Vocal Collection" est installée dans le créneau EXP-D.

NOTE

Si vous ne pouvez choisir aucun des morceaux musicaux de la carte d'extension Wave, il est possible que la carte installée ne soit pas reconnue correctement. Éteignez l'appareil comme indiqué dans "**Turning Off the Power**" (p. 26) et réinstallez la carte correctement.

Making Connections

The XP-30 does not contain an amp or speakers. In order to hear sound, you will need to connect it to a keyboard amp, audio system, or headphones. Refer to the following diagram and connect the XP-30 to the external equipment you are using.

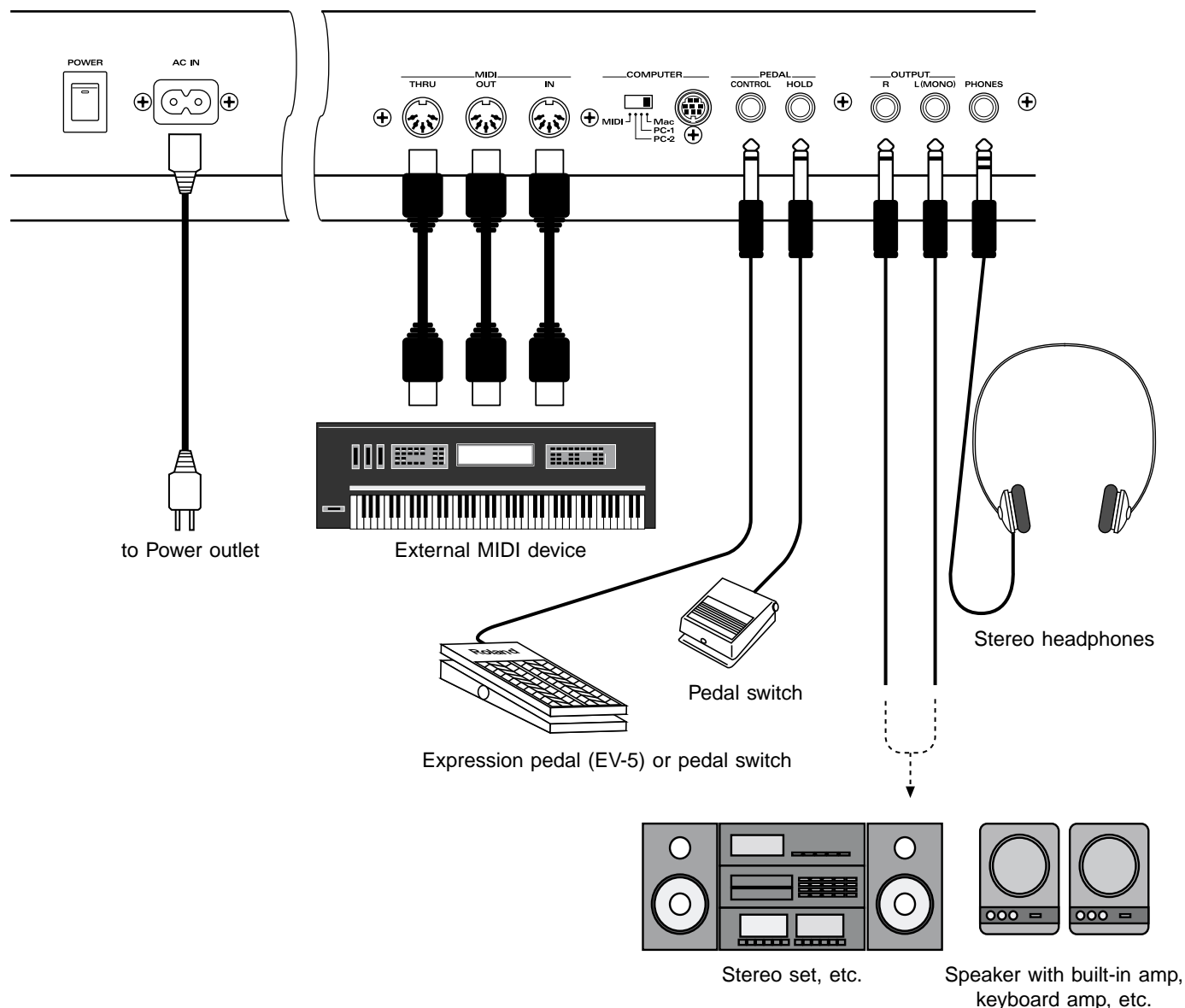

1

Before you make connections, make sure that power is turned off for all devices.

NOTE

To prevent malfunction and/or damage to speakers or other devices, always turn down the volume, and turn off the power on all devices before making any connections.

2 Connect supplied AC power cable to the XP-30, and plug the other end into an AC power outlet.

3 Connect audio cables and MIDI cables as shown in the diagram. If you are using headphones, plug them into the PHONES jack. Connect pedal switches or expression pedals as necessary.

NOTE

On 117V models the AC cable is permanently attached to the unit.

MEMO

In order to take full advantage of the XP-30's performance, we recommend using a stereo amp/speaker system. If you are using a mono system, make your connections to the OUTPUT jack L (MONO).

MEMO

CONTROL PEDAL jack can also accommodate pedal switches.

NOTE

Use only the specified expression pedal (EV-5; sold separately). By connecting any other expression pedals, you risk causing malfunction and/or damage to the unit.

MEMO

For information on making the connection with the computer, take a look at "Connecting to Your Computer" (p. 134).

Turning On the Power

- 1 Before you turn the power on, check to make sure that:
 - All external devices are correctly connected to the XP-30.
 - The volume controls of the XP-30 and the amp/mixer system are turned down all the way.

- 2 Turn on the power switch located on the rear panel of the XP-30.

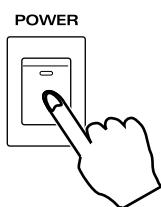

- 3 Turn the power on of your amp or audio system.

- 4 Play the XP-30 and gradually raise the volume controls of the XP-30, your amp or mixer to an appropriate volume level.

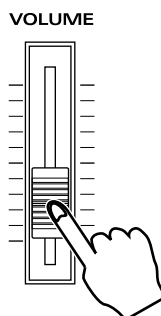

■ Turning Off the Power

- 1 Before you turn power off, check to make sure that:
 - The volume controls of the XP-30 and the amp/mixer system are turned down all the way.
 - Important data has been saved to a memory card (p. 122).

- 2 Turn off your amp/mixer system.

- 3 Turn off the XP-30 power.

NOTE

Once the connections have been completed (p. 24), turn on power to your various devices in the order specified. By turning on devices in the wrong order, you risk causing malfunction and/or damage to speakers and other devices.

NOTE

This unit is equipped with a protection circuit. A brief interval (a few seconds) after power up is required before the unit will operate normally.

NOTE

Be careful not to raise the VOLUME slider of the XP-30 too much. Excessive volume may damage your amp/speaker system or could cause hearing

Reset to Default Factory Settings (Factory Reset)

Before using XP-30 for the first time, reset it to its default factory settings using **Factory Reset**. Different settings may result in unexpected effects.

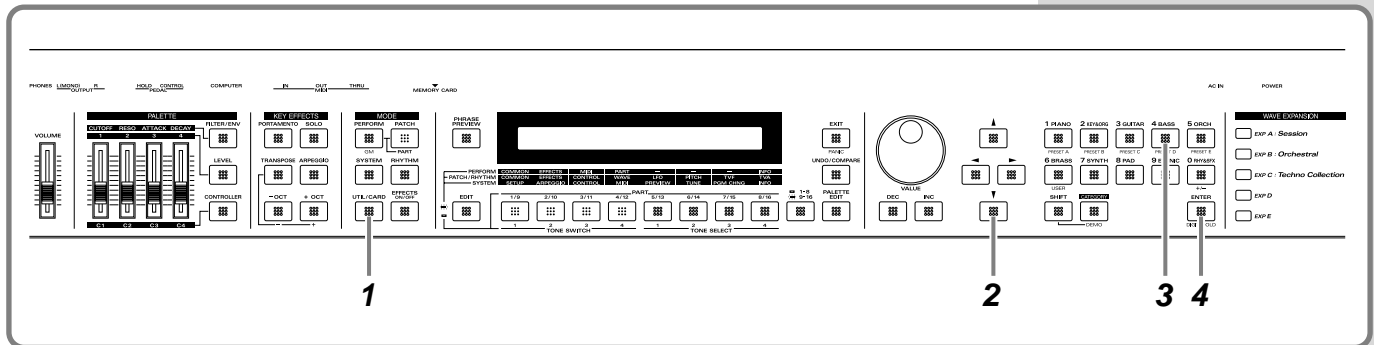

- 1 Press [UTIL/CARD] to make the indicator blink.

The UTIL 1 display will appear.

```
UTIL 1:WRITE | 2: COPY | 3: INIT | 4: XFER | 5: PRO-
  1 | | | | |
  1 | | | | |
  TECT
```

- 2 Press [▼].

The UTIL 2 display will appear.

```
UTIL 1: CARD | 2: LOAD | 3: SAVE | 4: FACTORY
  2 | | | | |
  2 | | | | |
  RESET
```

- 3 Press the numeric key [4].

The FACTORY RESET display will appear.

```
FACTORY RESET | [ENTER]
```

- 4 Press [ENTER].

If “Internal Write Protect= ON” message is displayed, press [DEC] to turn the setting OFF. After pressing [ENTER] to clear the message, press [ENTER] again to reset to the factory preset settings.

NOTE

Factory Reset operation resets all data in the internal memory and user memory to factory presets. Save any important data to a memory card before executing this operation (p. 122).

MEMO

For more information about the Internal Write Protect, please refer to “Preventing User Memory Writing Operation (PROTECT)” (p. 121).

Listening to the Demo Song

The XP-30 contains 9 demo songs and you use **Demo Play** to play it. It's the easiest introduction to the XP-30's exceptional sounds and effects.

Demo Song	Composer/Copyright
TRANSCERENCE	Scott Tibbs © 1999 Roland Corporation
CHANTERELLE	Scott Tibbs © 1999 Roland Corporation
VECTORIAL	Scott Tibbs © 1999 Roland Corporation
All In Good Time	Scott Wilkie © 1999 Scott Wilkie Media (ASCAP)
TEKKNO MILLENNIUM	MASA © 1999 COPYRIGHT CONTROL
A Shadow's March	Steve Lu © 1999 Stephen Lu
Guitars Forever	Gundy Keller © 1999 Gundy Keller / A-TOWN recordings
Rude99	Hans-Joerg Scheffler © 1999 Hans Scheffler
Overtime	Hans-Joerg Scheffler © 1999 Hans Scheffler



All rights reserved. Unauthorized use of this material for purposes other than private, personal enjoyment is a violation of applicable laws.

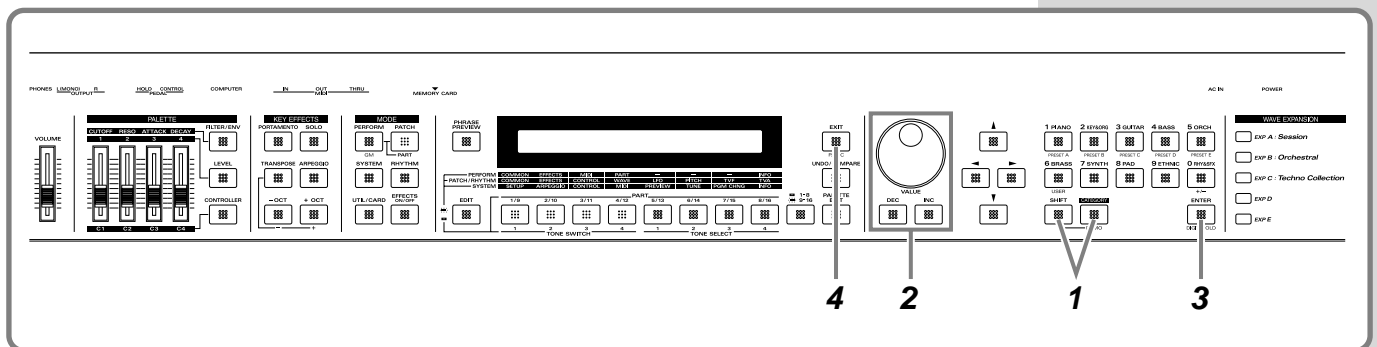

1 Hold down [SHIFT] and press [CATEGORY].

The DEMO PLAY display will appear.

```
DEMO  || Song          Press [ENTER]/[EXIT]
PLAY  || CHAIN-PLAY
```

2 Turn the VALUE dial or press [INC]/[DEC] to select the song that you wish to hear.

If you select "CHAIN-PLAY," the songs will playback successively, beginning from the first.

3 Press [ENTER] to start demo song playback.

When a demo song plays all the way to the end, it automatically returns to the start of the song, and playback is repeated. To interrupt playback, press [EXIT].

```
DEMO  || Playing... (CHAIN) Press [EXIT]
PLAY  || 1. TRANSCERENCE
```

4 To return to the previous display, press [EXIT].



No data for the music that is played will be output from MIDI OUT.

■ Profile of the Composer

Scott Tibbs

Scott Tibbs has performed and conducted for several orchestral groups, including the Atlanta Symphony Orchestra, throughout the United States, Canada, Latin America, and Japan. His diverse compositional output ranges from numerous film, theater and television projects to the symphonic concert stage. For the past four years, he has been teaching music composition and theory at UCLA where he has received a Ph.D. degree in composition. He has performed with well-known artists Dizzy Gillespie, Bill Cosby, Jerry Sienfeld, and Bobby Shew, amongst numerous others.

Gundy Keller

Gundy Keller, a Germany-based guitarist, songwriter and producer, has been an international demonstrator for Roland since 1986. Gundy focuses mainly on the GR synthesizers and the V-Guitar, for international music conventions as well as recording sessions requesting completely unusual guitar sounds. Besides creating his own production company, he's the founder and director of Rocksound Music School, a private institute for music instruction. Check out some of his other work on the Roland VG-8 Demo CD, or the Roland GR-30 Video.

Steve Lu

Steve Lu is a recent graduate of Berklee College of Music, majoring in Music Production & Engineering. His recent musical efforts include a soundtrack album, featuring synthesized re-creations of movie themes such as "Titanic" and "The Rock," as well as production and arrangements for saxophonist Jimmy Reid's self-titled album. He is currently working with artists Brandy and Ray-J on future projects.

Scott Wilkie

Scott Wilkie is a contemporary jazz recording artist, based in southern California. He tours frequently with his own band, and also appears as an artist for Roland in the U.S., Japan, Europe and South America. His debut solo album, Boundless, was released worldwide in 1999 on Narada/Virgin Records. You can find him on-line at www.scottwilkie.com.

Hans-Joerg Scheffler

Born and raised in the Ruhr valley, the biggest industrial area in Germany, Hans's attraction to noise and rhythm came naturally.

Today he runs his own company, DIGITAL AUDIO DESIGN, which produces sampling CDs and CD ROMs. He works for Roland as a pro audio product specialist, as a sound designer for expansion boards, and as a composer of demo songs. He has released several CDs that use the Roland RSS system.

Soundclips of his work can be downloaded at: <http://www.united-sound.com/usmaster/cell2downde.htm>

MASA

Masa has performed live, mainly at psychedelic-trance parties since the early 90's.

In the spring of 1996, he released the album "Just Inside" from East-West. Interest in his work is increasing, and new releases are appearing under a variety of labels, including Tokyo Tekno Tribe Records and Psy-Harmonics.

Web site: www.ifnet.or.jp/~masa-k/

Playing the Sounds

Selecting Patches and Playing the Sounds

The XP-30 contains a large number of sounds ready for you to play. The sounds that you select and play on the XP-30 are generally called **Patches**. Here's how to select and play Patches.

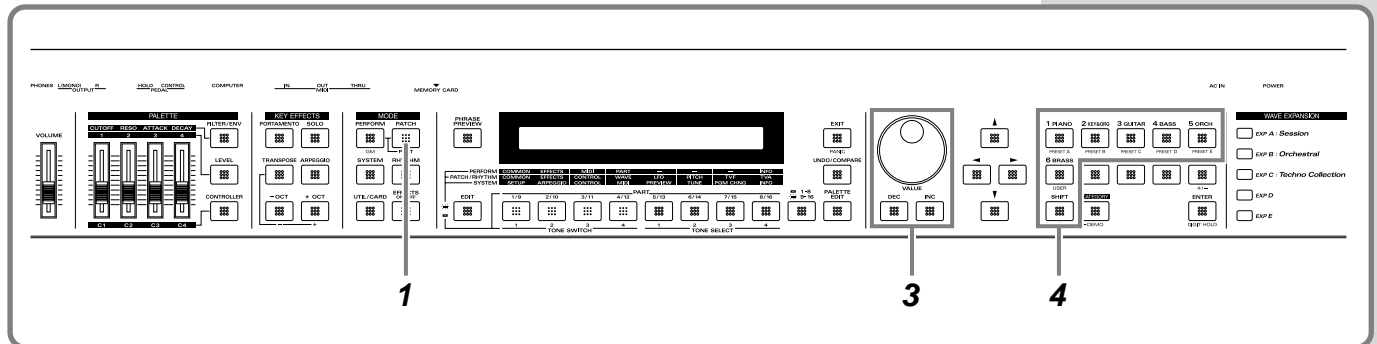

1 Press [PATCH] to make the indicator light.

The PATCH PLAY display will appear.

```
PATCH   USER:001 Temple of XP
PLAY                                center=C 4
```

2 Play the keyboard and listen to the sound.

3 To select a different Patch, turn the VALUE dial or press [INC]/[DEC].

4 To change the Patch Group, hold down [SHIFT] and press any key from [1] through [6] on the numeric keypad.

- [SHIFT] + [1]: PR-A (Preset A)
- [SHIFT] + [2]: PR-B (Preset B)
- [SHIFT] + [3]: PR-C (Preset C)
- [SHIFT] + [4]: PR-D (GM (General MIDI))
- [SHIFT] + [5]: PR-E (Preset E)
- [SHIFT] + [6]: USER (User)

MEMO

By using the Phrase Preview function, you can audition patches by listening to a preset phrase suitable for the selected type of patch (p. 33).

Selecting Wave Expansion Patches

The XP-30 contains the patches of the following popular Wave Expansion Boards:

- SR-JV80-09 “Session”
- SR-JV80-02 “Orchestral”
- SR-JV80-11 “Techno Collection”

Here’s how to select and play these patches.

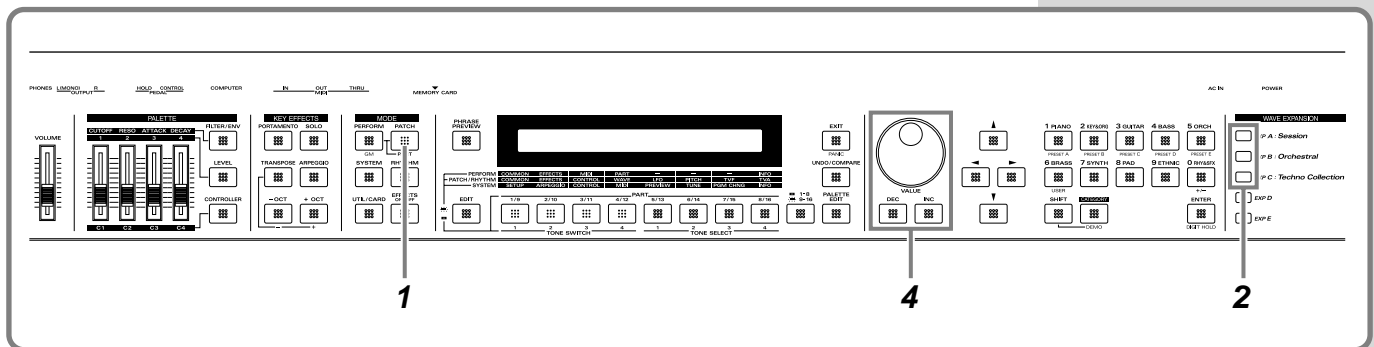

1 Press [PATCH] to make the indicator light.

The PATCH PLAY display will appear.

```
PATCH   USER:001 Temple of XP
PLAY                                center=C 4
```

2 Press [EXP A]-[EXP C] to select the Wave Expansion Patch that you wish to hear.

- [EXP A]: “Session”
- [EXP B]: “Orchestral”
- [EXP C]: “Techno Collection”

```
PATCH   XP-A:001 St. Concert
PLAY [Sessn]                       center=C 4
```

3 Play the keyboard and listen to the sound.

4 To select a different Patch, turn the VALUE dial or press [INC]/[DEC].

MEMO

When a Wave Expansion Board of the SR-JV80 series (sold separately) is installed in the EXP-D or EXP-E Wave Expansion Board slot, you can press [EXP D] or [EXP E] to choose the corresponding patches.

MEMO

By using the Phrase Preview function, you can audition patches by listening to a preset phrase suitable for the selected type of patch (p. 33).

Selecting Patches by Category (Patch Search Function)

The JV-2080 provides a **Patch Search Function** that allows you to quickly find Patches of the specified type (Category). The 38 categories are organized into 10 groups.

Here's an example of how to find organ-type Patches.

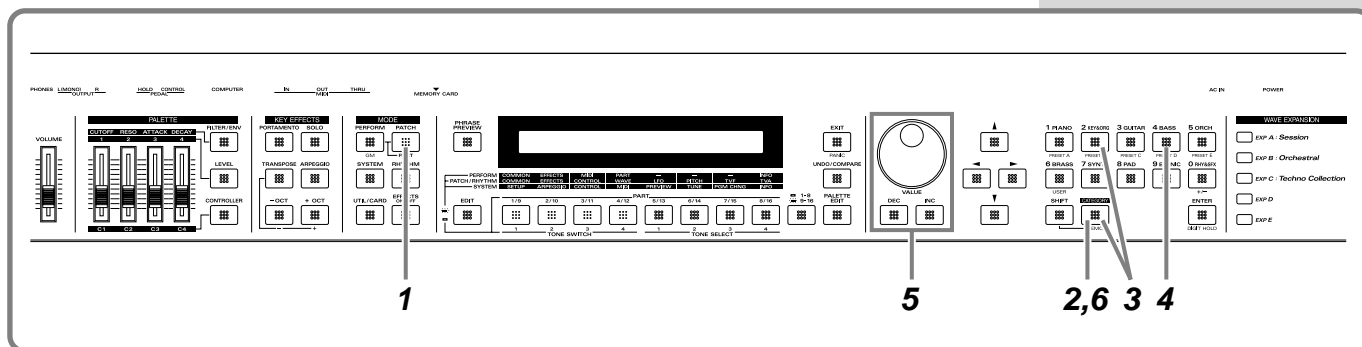

1 Press [PATCH] to make the indicator light.

The PATCH PLAY display will appear.

```
PATCH   USER:001 Temple of XP
PLAY                                center=C 4
```

2 Press [CATEGORY] to make the indicator light.

The Patch Search function will be turned on, and the patch number display will change to the category display.

```
PATCH   USER:PLS Temple of XP
PLAY                                center=C 4
```

3 Select the category. Hold down [CATEGORY] and press [2 (KEY&ORG)].

```
CATEGORY Keys&Organ ( KEYBOARDS)
SELECT  #1:KEY 2:BEL 3:MLT 4:ORG 5:ACD ▶
```

4 For this example, select the Organ category (ORG) by pressing numeric key [4].

Organ-type patches can now be selected.

MEMO

Now you can select patches within the specified category, either by rotating the VALUE dial, or by using [INC] or [DEC]. To change the category group, use the numeric keys.

MEMO

For details on the categories you can select, refer to page 49.

MEMO

By using the Phrase Preview function, you can audition patches by listening to a preset phrase suitable for the selected type of patch (p. 33).

5 Turn the VALUE dial or press [INC]/[DEC] to select a patch.

6 Press [CATEGORY] to make the indicator go dark.

The Patch Search function will be turned off, and the normal PATCH PLAY display will reappear.

Auditioning the Patches (Phrase Preview)

The XP-30 allows you to preview Patches by hearing a phrase appropriate for each type of Patch.

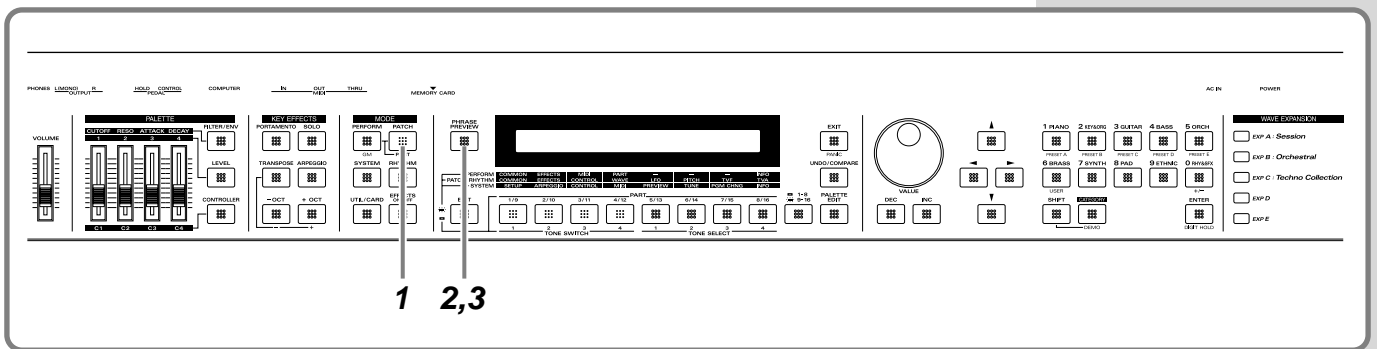

1 Press [PATCH] to make the indicator light.

The PATCH PLAY display will appear.

```
PATCH   USER:001 Temple of XP
PLAY                                center=C 4
```

2 Press and hold [PHRASE PREVIEW].

If the factory settings have just been restored, the **USER: 001 Temple of XP** Patch will sound.

3 Release your finger from [PHRASE PREVIEW], and the phrase will stop playing.

MEMO

You can change the phrase that is played by the Phrase Preview, and modify the way in which the phrase is played. For details, refer to “Using Phrase Preview to Play Patches” (p. 49), and “Phrase Preview Settings (PREVIEW)” (p. 113).

Try Out Performance Functions

The XP-30 provides various controllers that can modify the sound. While playing patches, try out these controllers and listen to effects they can produce.

■ Velocity/Aftertouch

The force with which you play the keyboard (velocity) can affect the volume or timbre of the sound. Aftertouch (pressure you apply to a key after playing a note) can also affect the sound.

■ Pitch Bend/Modulation Lever

While playing the keyboard, move the lever to the left to lower the pitch, or to the right to raise the pitch. This is known as **Pitch Bend**. You can also apply vibrato by manipulating the lever away from you. This is known as **Modulation**.

If you move the lever away from you and at the same time move it to the right or left, you can apply both effects simultaneously.

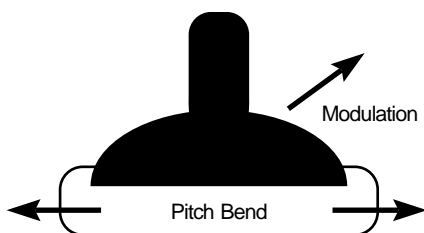

■ C1–C4 Slider

By moving the sliders up and down while fingering the keyboard, you can control the various functions assigned to the sliders.

To control them, press [CONTROLLER] to make the indicators light up, then move the sliders.

Additionally, if you hold down [CONTROLLER] while moving one of the C1–C4 sliders, you can go to the ASSIGN display for that slider. There you can check and make settings for the function that is to be controlled with the slider. Make changes in the settings while holding down [CONTROLLER].

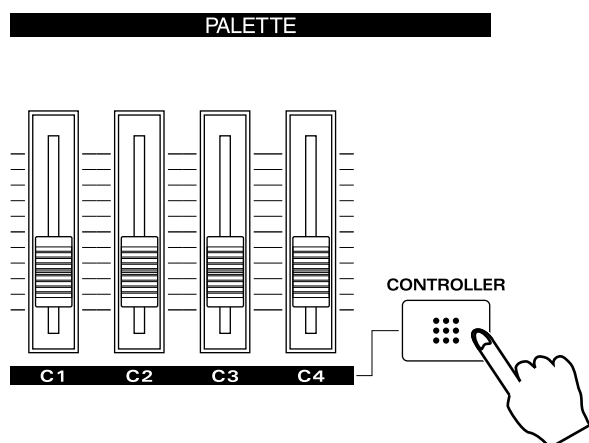

NOTE

The effect that the controllers have will depend on the settings of the selected Patch. If the effects of the controllers are difficult to detect, select another Patch.

MEMO

At the factory default settings, you can use the C1 through C4 sliders to control the functions described below.

C1: AFTERTAUCH

C2: BREATH

C3: PORTA-TIME

(Portamento time)

C4: MODULATION

NOTE

How sound varies depends on the current setting. For details, refer to “**C1/C2/C3/C4 ASSIGN (C1/C2/C3/C4 Slider Assign)**” (p. 111).

■ Hold Pedal

If an optional pedal switch is connected to the rear panel HOLD PEDAL jack, pressing the pedal switch will sustain (hold) the sound even if the keys are released.

■ Expression Pedal

If an optional expression pedal is connected to any of the rear panel CONTROL PEDAL jack, you can use the pedal to control the volume or timbre of sound.

■ Solo

You can play using single notes, by pressing [SOLO] (indicator lights). This function is especially effective when playing a sax, flute or other monophonic instrument.

Using [PORTAMENTO] with [SOLO] ON allows you to simulate performance techniques like violin glissandos.

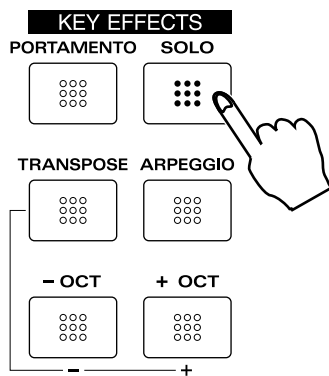

■ Portamento

As you play the keyboard, you can make pitch slide smoothly from one key to another, by pressing [PORTAMENTO] (indicator lights).

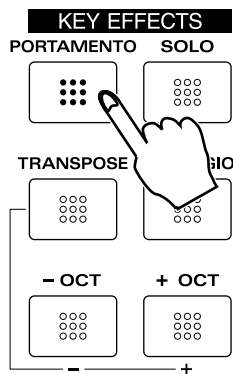

NOTE

How sound varies depends on the current setting. For details, refer to “CONTROL PEDAL” (p. 110).

MEMO

For details, refer to “Playing Single Notes (Solo)” (p. 50).

MEMO

For details, refer to “Creating Smooth Pitch Changes (Portamento)” (p. 50).

Playing the Sounds

■ Sound Palette

While playing the keyboard, you can move the sliders up or down to modify volume level or sound character.

To change sound character, press [FILTER/ENV] to light the indicator and move the sliders.

To change the volume level, press [LEVEL] to light the indicator and move the sliders.

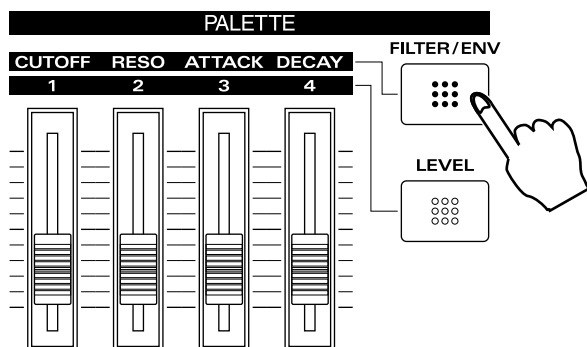

MEMO

For details, refer to “Using the Sliders to Modify the Sound in Realtime (Sound Palette Function)” (p. 50, 54).

Play Arpeggios (Arpeggiator)

You can play a broken chord (arpeggio) automatically, by simply pressing a chord. For example, if you press a C major chord, the XP-30 plays an arpeggio such as C → E → G → C → E → G...

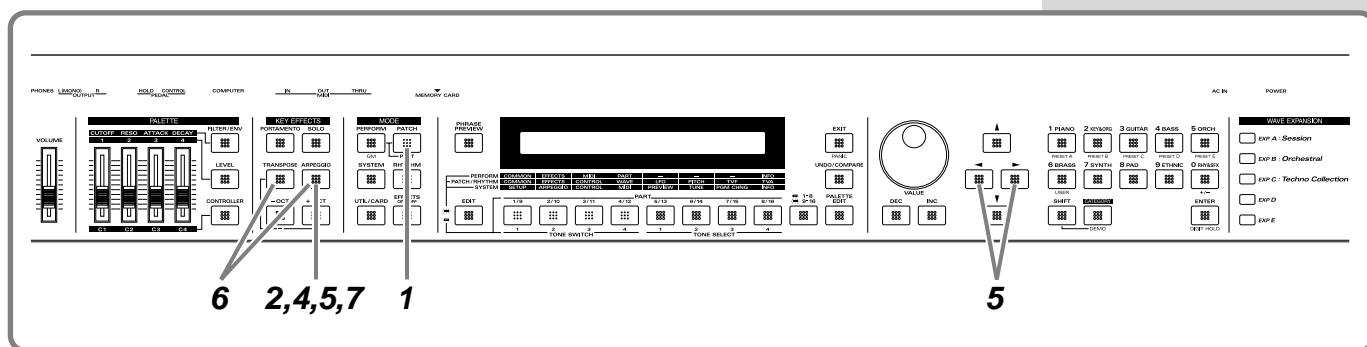

1 Press [PATCH] to make the indicator light.

The PATCH PLAY display will appear.

```
PATCH USER:001 Temple of XP
PLAY center=C 4
```

2 Press [ARPEGGIO] to make the indicator light.

3 Play a chord.

XP-30 will play an arpeggio, according to the notes forming the chord you have just voiced.

4 Continue holding down [ARPEGGIO], and the ARP SELECT display will appear.

```
ARP  █                               Style|Accent|Oct|Tempo
SELECT█                               1/16| 20%| 0| 120
```

In this page you can change the Style, Accent Rate, Octave Range and Tempo of the arpeggio. Here's how to change the Style.

5 Hold down [ARPEGGIO], and press [◀] or [▶] to move the cursor (underline) to the Style parameter. Then rotate the VALUE dial to select various settings.

Depending on the value you enter, the way arpeggios play will vary.

6 Hold down [ARPEGGIO] and press [TRANSPOSE]. The [ARPEGGIO] indicator will begin blinking, and the arpeggio will continue sounding even after you take your hand off the keyboard (Hold).

To stop the arpeggio from being sounded by the Hold function, hold down [ARPEGGIO] again and press [TRANSPOSE]. The indicator changes from blinking to lit.

7 To finish playing arpeggios, press [ARPEGGIO] again so the indicator turns off.

MEMO

For details regarding playing arpeggios, refer to “Playing an Arpeggio” (p. 56) and “Arpeggio Settings (ARPEGGIO)” (p. 108).

Play Percussion Sounds from the Keyboard

The XP-30's **Rhythm Sets** contain a wide variety of percussion sounds and special effects. Here's how to select a Rhythm Set and play percussion sounds.

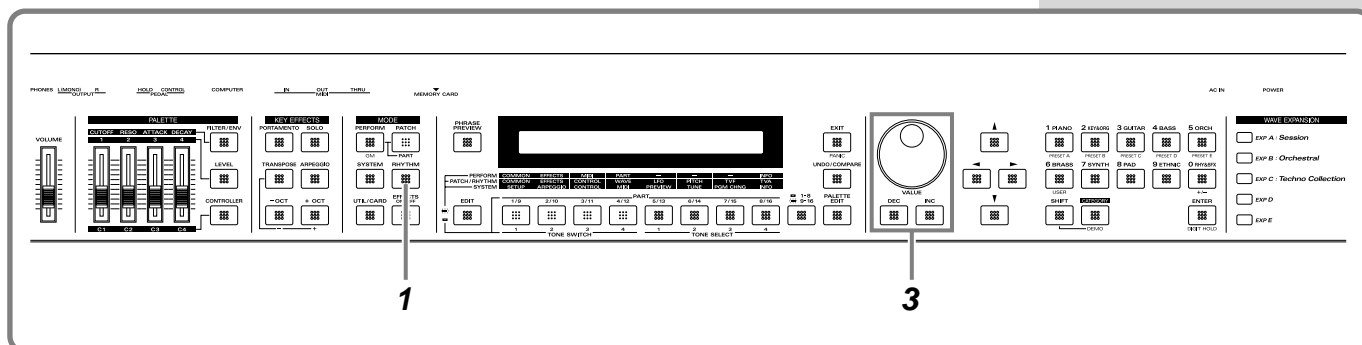

1 Press [RHYTHM] to make the indicator light.

The RHYTHM PLAY display will appear.

```
RHYTHM PR-A:002 PopDrumSet 2
PLAY      B 1(Hybrid Kick1)center=C 4
```

2 Press different keys to play different percussion instruments.

The display will indicate the last-pressed key (Note name) and the percussion instrument name (Rhythm Tone name) assigned to that key.

3 To select another Rhythm Set, turn the VALUE dial or press [INC]/[DEC].

MEMO

The percussion instrument played by each key will depend on the selected Rhythm Set. For details, refer to “**Rhythm Set List**” (p. 177).

XP-30

64 VOICE EXPANDABLE SYNTHESIZER

*"Session," "Orchestral" and "Techno Collection" onboard
2x EXPANSION*

Advanced Use

Chapter 1. Overview of the XP-30

XP-30 Configuration

■ Basic Configuration

The XP-30 consists of a sound source and controllers.

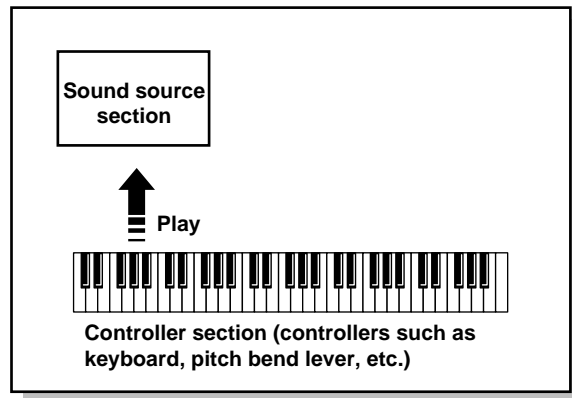

Sound Source

The XP-30 sound source produces sound by responding to commands in the form of MIDI messages received from its controllers. It will also produce sound by responding to commands received from various external devices it can be connected to.

Controllers

Controllers include the keyboard, front panel sliders and pedals which are connected to their respective rear panel jacks. Adjusting these controllers enable you to produce or modify sound.

■ Classification of XP-30 Sound Types

XP-30 sounds are made up of the following types:

Tones

In the XP-30, the Tone is the smallest class of sound. Each Tone consists of one sound. But when you play the XP-30 you will mostly play a Patch, which is made up of several Tones. Tones therefore are the elements which collectively form a Patch.

Tone configuration:

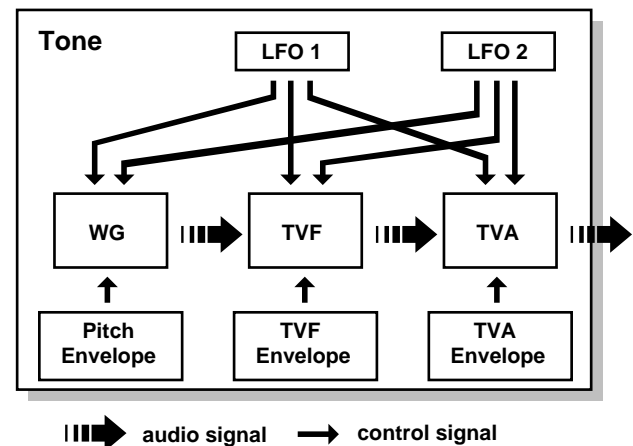

WG (Wave Generator)

Using the Wave Generator, you select a waveform and set its pitch.

TVF (Time Variant Filter)

With the Time Variant Filter, you modify the waveform's frequency characteristics.

TVA (Time Variant Amplifier)

With the Time Variant Amplifier, you set volume level and set the sound's position in a stereo soundfield.

Envelope

You use Envelope to initiate changes to occur to a sound over time. There are separate Envelopes for the WG (pitch), TVF (filter) and TVA (volume). For example, to modify a sound's attack and decay time, you would use TVA Envelope to adjust volume changes to the sound over time.

LFO (Low Frequency Oscillator)

Use the LFO to create cyclic changes (modulation) in a sound. The XP-30 has two LFOs. Either one or both can be applied to effect the WG (pitch), TVF (filter) and/or TVA (volume). To illustrate this control's action, you can apply an LFO to modify the WG (pitch) to create vibrato. If the LFO is used to modify the TVA (volume), you'll get tremolo.

Patches

Patches are the basic sound configurations that you play during a performance. Each Patch can be configured by combining up to four Tones. How the four Tones are combined is determined on the STRUCT display (PATCH/COMMON).

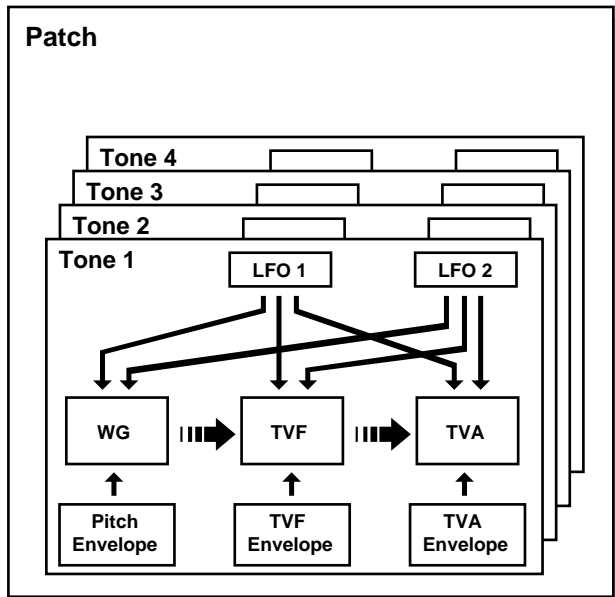

Performances

The next level in sound configuration. A single Performance groups 15 Patches and one Rhythm Set so that they can be combined to play ensembles or produce fabulously rich, thick sounds. One Performance allows a single XP-30 to control up to 16 instrument sounds. Because the XP-30 sound source can control multiple sounds (instruments) it is called a "multitimbral sound source."

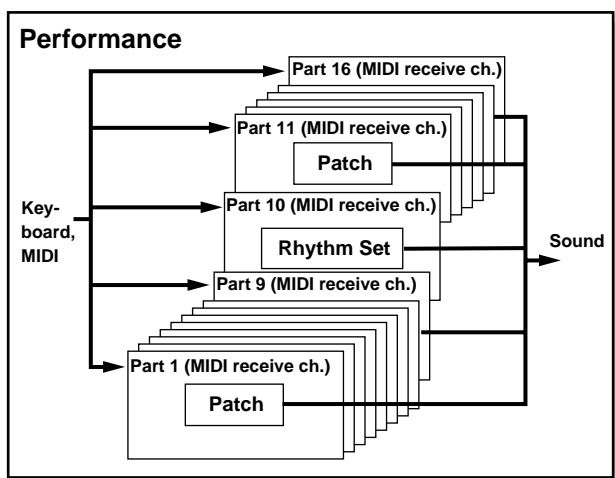

Rhythm Sets

A Rhythm Set is a grouping of percussion instruments (Rhythm Tones). Since percussion instruments generally do not play melodies, there is no need for a percussion instrument sound to be able to play a scale on the keyboard. It is however, more important that as many as possible percussion instruments be available to you at the same time. Therefore, each key (Note number) of a Rhythm Set will produce a different percussion instrument.

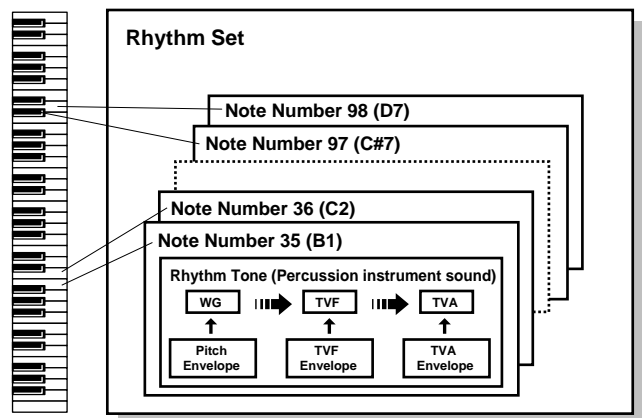

Parts

When the XP-30 is used as a multitimbral sound source, another sound configuration called a Part comes into play. A Part contains a Patch or Rhythm Set. For multitimbral applications, the Performance consists of 16 Parts. A specific Patch can be assigned to each Part except Part 10 because Part 10 is universally set as the Drum Part to which a Rhythm Set (discussed above) is assigned. In a multitimbral context, it helps to think of a Performance as an orchestra, each Part in it being a musician, and the Patch or Rhythm Set that musician's instrument.

For details regarding following items, please refer to each corresponding page.

About the Memory (p. 67)

About the Effects (p. 61)

■ Number of Simultaneous Voices

The XP-30 is able to produce up to 64 voices simultaneously. The following paragraphs discuss what this means, and what will happen when more than 64 simultaneous voices are requested from the XP-30.

Calculating the Number of Voices Being Used

The XP-30 is able to produce up to 64 simultaneous voices. However this number is not simply the number of notes being played, but depends on the number of Tones used in each Patch. If you are playing one Patch which uses 4 Tones, you will be able to play 16 simultaneous notes. If you are using the XP-30 in Performance mode to play an ensemble, count the total number of Tones used by all the Parts using the following formula.

(currently sounding notes) x (number of Tones used in the Patch being played)

How a Patch Uses Notes

When the XP-30 is requested to play more than 64 voices simultaneously, a currently-sounding note will be turned off to make room for the newly requested note. The note with the lowest priority will be turned off first. The order of priority is determined by the Voice Priority setting. Voice Priority can be set either to Last or Loudest. When Last is selected, a newly requested note that exceeds the 64 voice limit will cause the first-played of the currently sounding notes to be turned off. When Loudest is selected, the quietest of the currently sounding notes will be turned off. Normally you will set Voice Priority to Last.

Note Priority in Performance Mode

Since Performance mode is usually used to play an ensemble consisting of several Patches, it is important to decide which Parts take priority. Priority is specified by the Voice Reserve settings. When a note within a Patch needs to be turned off to make room for a new note, the Voice Priority setting of the Patch will apply.

Voice Reserve

The XP-30 has a Voice Reserve function that lets you reserve a minimum number of notes that will always be available for each Part. For example if Voice Reserve is set to 10 for Part 16, Part 16 will always have 10 notes of sound-producing capacity available to it even if a total of more than 64 notes (total for all Parts) are being requested. When you make Voice Reserve settings, you need to take into account the number of notes you want to play on each Part as well as the number of Tones used by the selected Patch.

* *It is not possible to make Voice Reserve settings that would cause the total of all Parts to be greater than 64 voices.*

Basic Operation

■ Switching Modes

The XP-30 contains a large number of functions. In order to organize these functions for easy access, they are grouped into the following modes. The mode that is selected will affect the way in which the sound source operates, how data is shown in the display, and how the function buttons work. Use the Mode buttons to select the mode. The indicator of the selected button will light/blink, and the display will change according to the selected mode.

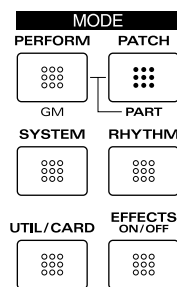

Sound Source

Selecting Patch mode, Performance mode, Rhythm Set mode, and GM mode will determine sound source operation. One mode always has to be selected.

Patch Mode

In this mode, you can play an individual Patch from the keyboard or modify Patch settings. If you're using an external MIDI device to control the XP-30 in this mode, it will function as a single-patch sound source.

Performance Mode

This mode makes the XP-30 function as a multitimbral sound source, and Performance settings can be modified. If you're using an external MIDI device to control the XP-30 in this mode, it will function as a multitimbral sound source. To modify the settings of a Patch that's assigned to a Part, hold down [PERFORM] and press [PATCH]. Both button indicators will light.

Rhythm Set Mode

This is how you can play a Rhythm Set from the keyboard and modify the Rhythm Set settings. In this mode, the keyboard will play the Rhythm Set, but the XP-30 continues to function as a multitimbral sound source. So your effects settings of the currently selected Performance will be heard as you play the Rhythm Set. Rhythm Sets are assigned to Part 10 of the Performance. If you're using an external MIDI device to control the XP-30 in this mode, it will still function as a multitimbral sound source.

GM Mode

This special mode makes the XP-30 function as a GM compatible sound source. You should select this mode when you want to play back a GM score (music files created for GM sound source).

To set GM mode, hold down [SHIFT] and press [PERFORM]. [PERFORM], [PATCH] and [RHYTHM] indicators will not light.

System Mode

This mode is for determining global XP-30 settings such as tuning, display contrast and how MIDI messages are received.

* Some System mode parameters relate to an entire Patch or an entire Performance. To set these parameters, press [SYSTEM] in the selected mode (Patch or Performance).

Utility/Card Mode

Here you can save and transmit settings for the sound generator, and make settings related to memory cards.

* Some Utility/Card mode parameters relate to an entire Patch, Performance or Rhythm Set. To set these parameters, press [UTIL/CARD] in the selected mode (Patch, Performance or Rhythm Set).

About the Function Buttons

Function buttons are buttons that perform a variety of functions. The function they perform will depend on the current mode, and on whether [EDIT] is on (lit) or off (dark). [EDIT] will turn on or off each time you press it.

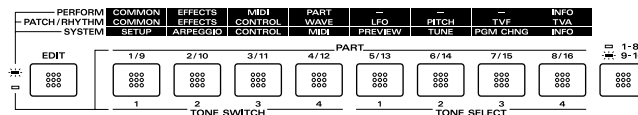

* [EDIT] switches the function of the function buttons, but pressing [EDIT] will not make the display change. If you wish to modify a setting, press the [EDIT] to make the indicator light, and then press a function button to select the display group and switch the display. When you finish making settings, press [EXIT] or a mode button to switch the display.

In Performance Mode ([EDIT] Indicator is Dark)

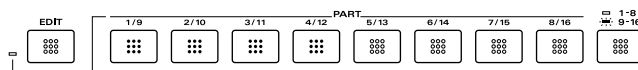

The function buttons will act as Part buttons ([PART]) that switch Parts on (lit) or off (dark). Since 16 Parts are being controlled using only 8 buttons, use [1-8/9-16] to select which set of Parts you are controlling. When [1-8/9-16] indicator is dark, you can switch Parts 1-8 on/off. When it is lit, you can switch Parts 9-16 on/off.

If the [EDIT] indicator is turned off in the Part setting display, the function buttons will act as PART buttons that select the Part to be edited.

* The function of the Part on/off setting will depend on the setting of the Key Mode parameter (PERFORM/COMMON/PERFORM COMMON) (p. 83).

In Patch Mode ([EDIT] Indicator is Dark)

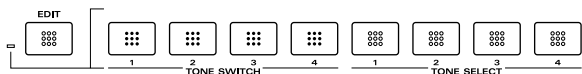

The function buttons will act as Tone Switch buttons ([TONE SWITCH]) and Tone Select buttons ([TONE SELECT]).

[TONE SWITCH] allow you to turn each Tone in the Patch on (lit) or off (dark). When a Tone is turned on, it can be heard.

Use [TONE SELECT] to select the Tone you wish to modify. To select a Tone to modify, turn off [EDIT] indicator in the Tone setting display. To select two or more Tones simultaneously, hold down one of [TONE SELECT] and press the other [TONE SELECT]. In this case, the numbers of Tones other than the first-selected Tone will be displayed as * symbols.

In Rhythm Set Mode ([EDIT] Indicator is Dark)

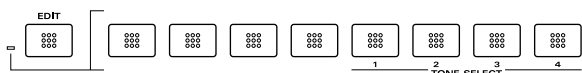

The function buttons (TONE SELECT section) will select the key shown in the display.

If the [EDIT] indicator is turned off in the Rhythm Set setting display (the setting display for individual keys), the function buttons will select the key to be edited.

- [TONE SELECT 1]: move to an octave lower key
- [TONE SELECT 2]: move to the semitone below
- [TONE SELECT 3]: move to the semitone above
- [TONE SELECT 4]: move to an octave higher key

When [EDIT] Indicator is Lit

Each mode contains a large number of settable items, and these items are organized into groups. When [EDIT] indicator is lit, the function buttons are used to select display groups. The displays that appear will depend on the current mode. The groups that can be selected in each mode are printed on the front panel above the buttons.

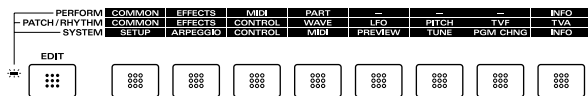

* For information on what the function buttons do in GM mode, please see “Chapter 5. Using the XP-30 as the GM Sound Module” (p. 124).

About the Cursor Buttons

The cursor buttons are used to move between display pages or to move the cursor.

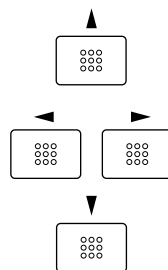

Moving Between Display Pages

The various displays are grouped by function button, and each group contains several display pages. Use the cursor buttons to move between these display pages and groups.

Moving Between Pages

An upward-pointing arrow (⬆) shown in the display indicates that one or more pages exist before this page. A downward-pointing arrow (⬇) shown in the display indicates that one or more pages exist after this page. Press [▲] to move to the previous page, or [▼] to move to the next page. Pressing [▲] while holding [SHIFT] will jump to the first page. Pressing [▼] while holding [SHIFT] will jump to the last page.

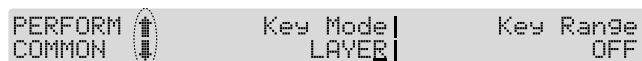

Moving Between Groups

From one of the Play displays, hold down [SHIFT] and press [▶] to access the left-most function button group display. In group displays that you select using the function buttons, you can hold down [SHIFT] and press [◀] to move to the group of the function button to the left, or hold down [SHIFT] and press [▶] to move to the group of the function button to the right.

Whenever you are in any group display, you can move to another group even if [EDIT] indicator is dark. In other words, this procedure allows you to move to a different group without having to turn on [EDIT] indicator, and is a faster and more efficient way to get around.

Moving the Cursor (underline)

When two or more items are shown in a single display page, move the cursor (underline) to the item whose value you wish to set. Press [◀] to move the cursor to the left, or [▶] to move it to the right.

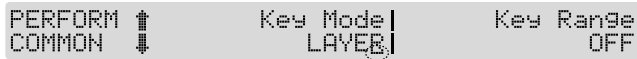

A symbol appearing in the upper right of the display indicates that there are other items in this page that the screen has no room to show. Press [▶] to see these items, and press [◀] to return to the previous display.

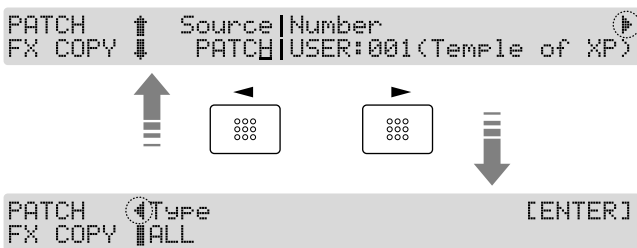

■ Modifying a Value

To modify a value, use the VALUE dial, [INC]/[DEC] or [0]-[9] (numeric keys).

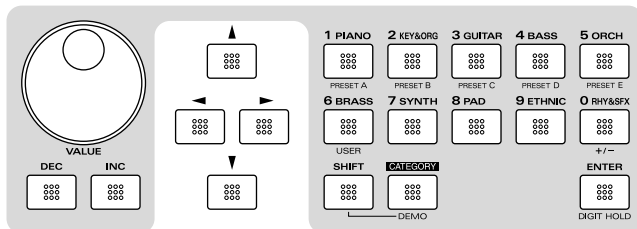

* Each parameter has a specific range, so you cannot set any value smaller than the minimum value or greater than the maximum value.

VALUE Dial

Rotating the VALUE dial clockwise increases the value, counterclockwise decreases the value. Holding down [SHIFT] as you move the VALUE dial increases value increments so you can make large value changes faster.

[INC] and [DEC]

Pressing [INC] increases the value, and [DEC] decreases it. Keep [INC] or [DEC] pressed for continuous adjustment. For faster value increases, keep [INC] pressed down and press [DEC]. For decreasing value faster, keep [DEC] pressed down and press [INC].

If you press [INC] or [DEC] while holding down [SHIFT], the value increments will get bigger.

[0]-[9] (Numeric Keys)

[0]-[9] (Numeric Keys) lets you directly specify a numerical value. When you enter the number, the value will blink. This indicates that the value has not yet been finalized. To finalize the value press the ENTER button. To reverse the sign of the number (+/-), hold down [SHIFT] and press [0].

* Some parameters do not require you to press [ENTER] to finalize the value.

< Example 1: To enter a value of 38 >

Press [3] → press [8] → press [ENTER]

< Example 2: To enter a value of -60 >

While holding down [SHIFT] press [0] → press [6] → press [0] → press [ENTER]

* You can switch from a positive to negative numerical value anytime before you press [ENTER].

Special Functions of the Numeric Keys

You can use the numeric keys to specify non-numerical settings for some parameters.

* For the procedure of using the Numeric Keys to enter the characters or symbols in a name, refer to “Assigning a Name” (p. 46).

Performance/Patch/Rhythm Set Group

In the PLAY displays of Performance mode/Patch mode/Rhythm Set mode, you can use the numeric keys to specify groups. To specify the group, hold down [SHIFT] and press numeric keys to specify groups.

Buttons

- [SHIFT]+[1]
- [SHIFT]+[2]
- [SHIFT]+[3]
- [SHIFT]+[4]
- [SHIFT]+[5]
- [SHIFT]+[6]

Group

- PR-A (preset A)
- PR-B (preset B)
- PR-C (preset C)
- PR-D (GM (General MIDI))
- PR-E (preset E)
- USER (user)

Restoring a Previous Value (Undo)

If you wish to restore a value to its immediate previous value, press [UNDO/COMPARE] to return the value to its pre-modified state.

The Undo function can be used when modifying sound source settings.

■ Assigning a Name

The XP-30 lets you assign names to Patches, Performances, and Rhythm Sets. The procedure is the same for any type of data. To assign a name, use [◀]/[▶] to move the cursor to the location where you wish to input a character. Then use the VALUE dial or [INC]/[DEC] or the Numeric Keys to input a character.

Available characters/symbols:

space, A—Z, a—z, 0—9, + - * / | = ! ? < > () [] ; : , . “ ` ` # % & \$ ¥ @ ^ _

Using the Numeric Keys

The numeric keys are used to input the numerals printed on each key as well as the characters assigned to each key (see the table below). Each time you press a numeric key, the display will cycle through the numeral and characters printed above the key. To specify a lowercase character, hold down [SHIFT] as you press the numeric key.

<u>Numeric Key</u>	<u>Character</u>
[1]	A B C
[2]	D E F
[3]	G H I
[4]	J K L
[5]	M N O
[6]	P Q R
[7]	S T U
[8]	V W X
[9]	Y Z !
[0]	space

Convenient Functions

While you are holding down [SHIFT], the screen will show three functions that are convenient when entering a name. To use each function, hold down [SHIFT] and press the appropriate function button.

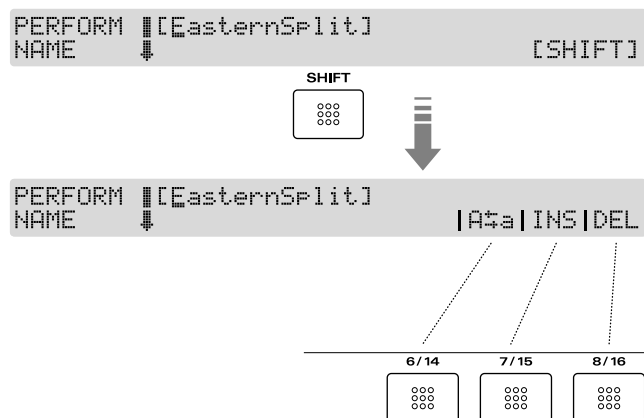

A ↺ a: switch between uppercase/lowercase characters

INS: insert a space at the cursor location

DEL: delete the character at the cursor location

Chapter 2. Playing

Playing in Patch Mode

Patches are what you normally play during a performance. Select a Patch before playing.

■ Selecting a Patch

The 768 patches of the XP-30 are organized into six groups of 128 patches: User, and Preset A–E. In addition, the patches of three popular Wave Expansion Boards (“Session,” “Orchestral,” and “Techno Collection”) are also stored onboard. Furthermore, you can install up to two separately available Wave Expansion Boards, which will allow you to choose from as many as 2044 patches.

USER

The XP-30’s user memory contains 128 Patches that can be rewritten to create your own Patches.

PR-A–C, E (Presets A–C, E)

The XP-30 includes 512 preset Patches that are not user-rewritable. But you can call up preset Patch settings into the temporary area, modify them, and then store them in User memory.

PR-D (GM (General MIDI))

GM Patches are for instruments compatible with the GM System. The aim of this system is to standardize MIDI specifications among different equipment makers or models. The XP-30 contains 128 GM Patches that are not user-rewritable. But you can call up GM Patch settings into the temporary area, modify them, and then store them in User memory.

XP-A–C (Internal Wave Expansion)

The patches of three Wave Expansion Boards (766 patches) are already built into the XP-30, and cannot be rewritten. However you may modify the settings of the currently selected patch, and then store the modified patch in User memory.

XP-D, E (Wave Expansion Boards installed in EXP-D, E Slots)

The Patches included in optional Wave Expansion Boards are not user-rewritable. But you can call up those Patch settings into the temporary area, modify them, and then store them in User memory.

* A Patch XP-D, E cannot be accessed if the Wave Expansion Board it belongs to has not been installed.

1. Press [PATCH] to call up the PATCH PLAY display.

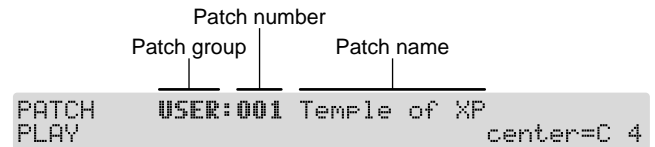

2. Rotate the VALUE dial or press [INC]/[DEC] to select a Patch.

Selecting a Patch Using Numeric Keys

You can use numeric keys to directly select a desired Patch.

1. Press [PATCH] to call up the PATCH PLAY display.
2. Press the following buttons to select a Patch group.

Button	Patch Group
[SHIFT] + [1]	PR-A (Preset A)
[SHIFT] + [2]	PR-B (Preset B)
[SHIFT] + [3]	PR-C (Preset C)
[SHIFT] + [4]	PR-D (GM (General MIDI))
[SHIFT] + [5]	PR-E (Preset E)
[SHIFT] + [6]	USER (User)
[EXP A]	XP-A (“Session”)
[EXP B]	XP-B (“Orchestral”)
[EXP C]	XP-C (“Techno Collection”)
[EXP D]	XP-D (Wave Expansion Board D)
[EXP E]	XP-E (Wave Expansion Board E)

3. Use numeric keys to input a Patch number. The patch number and name will blink. At this time, the Patch selection has not yet been finalized.
4. Press [ENTER] to finalize the entry.

Express Patch Select (Digit Hold)

With the Digit Hold function turned on, the 100's position and 10's position will be fixed when the numeric keys are used to select a Patch. This means that the numeric keys will only change the 1's position, and you won't have to press [ENTER] for each selection. The same applies to selecting Performances and Rhythm Sets.

1. Hold down [SHIFT] and press [ENTER] to turn on Digit Hold.

```
PATCH   USER:001 Temple of XP
PLAY    center=C 4
```

The numbers in the 100's position and 10's position will be displayed in a smaller size to indicate Digit Hold is on.

2. When you enter a numeric key number, the 1's position will change immediately without having to press [ENTER].
3. To turn off Digit Hold, hold down [SHIFT] and press [ENTER] once again.

Selecting Patches by Category (Patch Search Function)

The XP-30 provides a **Patch Search function** which allows you to specify a type (category) of Patch so that you can quickly find the desired Patch. There are a total of 38 categories.

1. Press [PATCH] to call up the PATCH PLAY display.
2. Press [CATEGORY] to turn the Patch Search function is on.

The patch number display will change to the category display.

* Now you can select patches within the currently selected category either by rotating the VALUE dial or by using [INC]/[DEC]. To change the category group, use the numeric keys.

If you wish to select patches from a different category, continue with the following procedure.

3. Hold down [CATEGORY] and press a key [0]–[9] (numeric keys) to select the category group.

```
CATEGORY Keys&Organ ( KEYBOARDS)
SELECT 1:KEY 2:BEL 3:MLT 4:ORG 5:ACD
```

4. Rotate the VALUE dial or press [INC]/[DEC] to select a Category.

The selected category display will blink. At this time, the selected category has not yet been finalized.

* Now if you press [▼] the following display will appear, and you can select patches while viewing the number of patches (a) included in the currently selected category, and the order of this patch among the patches (b) that were selected after the search. To change the category, use the numeric keys.

```
CATEGORY Keys&Organ Keyboards
SELECT PR-A:036 Phaze Clav 1 6/30
                    | |
                    (b) (a)
```

5. Press [ENTER] to finalize the entry.
- * In step 4, you can also select a category directly by pressing the corresponding numeric key.
6. Rotate the VALUE dial or press [INC]/[DEC] to select a Patch.
7. Press [CATEGORY] to turn the Patch Search function is off.

You will return to the normal PATCH PLAY screen.

The following categories can be selected.

Category Group	Category	Contents
	---	NO ASSIGN
		No assign
Piano		
	PNO AC.PIANO	Acoustic Piano
	EP EL.PIANO	Electric Piano
Keys&Organ		
	KEY KEYBOARDS	Other Keyboards (Clav, Harpsichord etc.)
	BEL BELL	Bell, Bell Pad
	MLT MALLET	Mallet
	ORG ORGAN	Electric and Church Organ
	ACD ACCORDION	Accordion
	HRM HARMONICA	Harmonica, Blues Harp
Guitar		
	AGT AC.GUITAR	Acoustic Guitar
	EGT EL.GUITAR	Electric Guitar
	DGT DIST.GUITAR	Distortion Guitar
Bass		
	BS BASS	Acoustic & Electric Bass
	SBS SYNTH BASS	Synth Bass
Orchestral		
	STR STRINGS	Strings
	ORC ORCHESTRA	Orchestra Ensemble
	HIT HIT&STAB	Orchestra Hit, Hit
	WND WIND	Winds (Oboe, Clarinet etc.)
	FLT FLUTE	Flute, Piccolo
Brass		
	BRS AC.BRASS	Acoustic Brass
	SBR SYNTH BRASS	Synth Brass
	SAX SAX	Sax
Synth		
	HLD HARD LEAD	Hard Synth Lead
	SLD SOFT LEAD	Soft Synth Lead
	TEK TECHNO SYNTH	Techno Synth
	PLS PULSATING	Pulsating Synth
	FX SYNTH FX	Synth FX (Noise etc.)
	SYN OTHER SYNTH	Poly Synth
Pad		
	BPD BRIGHT PAD	Bright Pad Synth
	SPD SOFT PAD	Soft Pad Synth
	VOX VOX	Vox, Choir
Ethnic		
	PLK PLUCKED	Plucked (Harp etc.)
	ETH ETHNIC	Other Ethnic
	FRT FRETTED	Fretted Inst (Mandolin etc.)
Rhythm&SFX		
	PRC PERCUSSION	Percussion
	SFX SOUND FX	Sound FX
	BTS BEAT&GROOVE	Beat and Groove
	DRM DRUMS	Drum Set
	CMB COMBINATION	Other Patches which use Split and Layer

■ Using Phrase Preview to Play Patches

The XP-30 allows you to preview Patches by hearing a phrase appropriate for each type of Patch.

1. Select a Patch (p. 47).
2. Press and hold [PHRASE PREVIEW].
 - * When a Performance is selected, the Patch of the Part for which settings are being made will sound. When a Rhythm Set is selected, a drum phrase will sound.
 - * Patches of the USER group or from an optional Wave Expansion Board (SR-JV80 series) may not sound at the appropriate pitch range. In this case, use [+OCT] or [-OCT] (the Octave Shift function) to set an appropriate pitch range.
 - * If the range of the phrase is wider than the range of the Tones within the Patch (p. 70), or wider than the range of the Parts within the Performance (p. 83), the portion of the phrase that exceeds the range will not sound.
3. The phrase will stop playing when you take your finger off [PHRASE PREVIEW].
4. Hold down [SHIFT] and press [PHRASE PREVIEW], and the PREVIEW SELECT display will appear. Here you can specify how the phrase will be played (Mode), and select the phrase that will play (Patch Category).

```
PREVIEW | Mode | Patch Category
SELECT | PHRASE | PULSATING(PLS)
```

5. To specify how the phrase will be played, use the cursor buttons to move the cursor to the Mode parameter.
6. Rotate the VALUE dial or press [INC]/[DEC] to make the setting.

Mode (Preview Sound Mode)

SINGLE: The notes specified by Note 1–4 parameter (SYSTEM/PREVIEW/PREVIEW KEY) will sound successively one by one.

CHORD: The notes specified by Note 1–4 parameter (SYSTEM/PREVIEW/PREVIEW KEY) will sound simultaneously.

PHRASE: The phrase prepared for the Patch type (category) will sound.

* This setting is linked with the Mode parameter (SYSTEM/PREVIEW/PREVIEW MODE).

7. If you set the Mode parameter to PHRASE, you can specify the phrase that will sound. Use the cursor buttons to move the cursor to the Patch Category parameter.
 - * If a rhythm set is selected, this will be fixed at DRUMS, and it will not be possible to change the phrase that is played.

8. Rotate the VALUE dial or press [INC]/[DEC] to make the setting. For details on the available categories, refer to page 49.

* *This setting is linked with the Category parameter (PATCH/COMMON/PATCH CATEGORY).*

■ Making a Patch Sound Thick or Thin (Turning a Tone On/Off)

Since a Patch is a combination of up to four Tones, you can switch unwanted (Tones out of the four) off and get just the sound of a specific Tone.

* *This setting is linked with the Switch parameter (PATCH/WAVE/WAVE). If you want just one or two Tones to sound in a Patch, turn the others off and store that setting on a Patch. This cuts nonessential use of the XP-30's simultaneous voices.*

1. Make sure that the PATCH PLAY display is showing.
2. Make sure that [EDIT] indicator is dark. If it is lit, press [EDIT].

At this time, the on/off setting of each Tone in the displayed Patch will be shown by the indicators of TONE SWITCH [1]–[4]. Those that are lit are on, and those that are dark are off.

3. Use TONE SWITCH [1]–[4] to switch Tones on/off.

■ Playing Single Notes (Solo)

Normally, the XP-30 allows you to play chords. Pressing [SOLO] allows performance using single notes. This function is effective when performing a solo using single-note Patches like sax and flute.

1. Make sure that the PATCH PLAY display is showing.
2. Press [SOLO] so its indicator lights.

Now you can play a solo.

* *This setting is linked with the Assign parameter (PATCH/CONTROL/KEY MODE & BENDER). When the [SOLO] indicator is turned on, the Assign parameter will be set to SOLO. When the indicator is dark, it will be set to POLY.*

3. Play the XP-30 keyboard.

* *If you press [SOLO] when Single Performance is selected, the Solo function can be switched on or off for the current Part. When Layer Performance is selected, the Solo function can be switched on or off for the Parts with the Local parameter (PERFORM/MIDI/MIDI) set ON. If a Rhythm Set is selected, [SOLO] cannot be turned on.*

■ Creating Smooth Pitch Changes (Portamento)

Portamento ensures a smooth pitch changeover from one note to the next note played. When [SOLO] is on (indicator lights), you can simulate techniques like violin glissandos.

1. Make sure that the PATCH PLAY display is showing.
2. Press [PORTAMENTO]. Its indicator lights. You're ready to play portamento.

* *This setting is linked with the Sw parameter (PATCH/CONTROL/PORTAMENTO).*

3. To change the portamento settings, press [EDIT] to make the indicator light. Then press the [CONTROL] function button, and press [▲] or [▼] to access the PORTAMENTO display.

```
PORTA-  ↑ Sw|Time|  Mode|   Type|  Start
MENTO  ↓OFF|  0|NORMAL|  RATE|  PITCH
```

4. Move the cursor over to Time, Mode, Type or Start parameter.
See p. 73 for each parameter's functions.
5. Rotate the VALUE dial or press [INC]/[DEC] to get the value you want.
6. Press [EXIT] to return to the PATCH PLAY display and play.

* *If you press [PORTAMENTO] when Single Performance is selected, the Portamento function can be switched on or off for the current Part. When Layer Performance is selected, the Portamento function can be switched on or off for the Parts with the Local parameter (PERFORM/MIDI/MIDI) set ON. If a Rhythm Set is selected, [PORTAMENTO] cannot be turned on.*

■ Using the Sliders to Modify the Sound in Realtime (Sound Palette Function)

With the four sliders in the PALETTE section, you can create sound variations or volume changes in real time.

- * *Sound variations or volume changes made with the Sound Palette affect only the performance. They have no effect on current Patch settings. Change the Patch and these Sound Palette settings will be lost.*
- * *The sound character and volume changes created using the Sound Palette will also be transmitted to the external MIDI devices.*

Changing Sound Characters

1. Make sure that the PATCH PLAY display is showing.
2. Press [FILTER/ENV] and its indicator lights.
3. Move the sliders while you play to vary the sound.
To modify the brightness, move the CUTOFF slider.
To change resonance, move the RESO. slider.
To change attack time, move the ATTACK slider.
To change decay time, move the DECAY slider.

Changing the Volume of Each Tone

1. Make sure that the PATCH PLAY display is showing.
2. Press [LEVEL] and its indicator lights.
3. Move the LEVEL slider as you play the keyboard to adjust volume as desired.

Sliders 1, 2, 3, and 4 are used to change the volume of Tones 1, 2, 3, and 4, respectively.

Playing in Performance Mode

There are two types of performances: **Layer performances** and **Single performances**. The upper right of the display will indicate “LAYER p*” (* is the part number) for a layer performance, and “part=*” (* is the part number) for a single performance.

Layer Performance allows playing two or more Parts simultaneously on the keyboard. Select Layer Performance if you want fat, rich sounds of two or more Patches, or play different Patches in a split keyboard’s different sections.

Single Performance plays only the Part shown in the display (current Part). Select Single Performance for playing a song using two or more instruments.

- * *Make your Performance type selection with the Key Mode parameter (PERFORM/COMMON/PERFORM COMMON). The Key Mode parameter determines how the XP-30 keyboard will play the internal sound source. It has no effect on how the XP-30 sound source is played from the built-in sequencer or an external MIDI device.*
- * *You can toggle between SINGLE and LAYER directly from the PERFORM PLAY display by pressing [SOLO] while holding down [SHIFT].*

Selecting a Performance

The XP-30 offers three groups of Performances (User, Presets A and B) with each group having 32 Performances. A total of 96 Performances is available.

USER

The XP-30 user memory includes 32 Performances that can be rewritten to produce your own Performances.

PR-A-B (Preset A-B)

The XP-30 contains 64 preset Performances that cannot be rewritten. But you can call up preset Performance settings into the temporary area, modify them, and then store them in user memory.

1. Press [PERFORM] to call up the 52 PERFORM PLAY display.

The screenshot shows the PERFORM PLAY display with the following text: "PERFORM USER: 01 EasternSplit LAYER p 1" and "PLAY center=C 4". Above the display, labels indicate "Performance group" pointing to "USER: 01", "Performance number" pointing to "01", and "Performance name" pointing to "EasternSplit".

2. Rotate the VALUE dial or press [INC]/[DEC] to select a Performance.

Selecting a Performance Using Numeric Keys

You can choose a Performance with direct numeric key input.

1. Press [PERFORM] to call up the PERFORM PLAY display.
2. Use the following buttons to select the Performance group.

Button	Performance Group
[SHIFT] + [1]	PR-A (Preset A)
[SHIFT] + [2]	PR-B (Preset B)
[SHIFT] + [6]	USER (User)

3. Use numeric keys to input the Performance number. The performance number and name will blink. At this time the Performance has not yet been finalized.

4. Press [ENTER] to finalize the entry.

* *Using Digit Hold, a Performance can be selected simply by specifying the 1's place number (p. 48).*

■ Playing Fatter and Richer Sounds by Combining Patches (Layer)

If a Layer Performance is selected, you can play all Parts with the Local parameter ON. Combining the Parts will produce, thicker, fatter sounds.

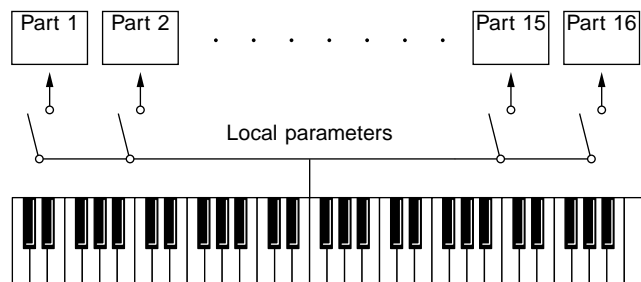

1. Make sure that PERFORM PLAY display is showing.
 2. Make sure that the upper right of the display indicates "LAYER p*" (* is the part number). If the display indicates "part=*" (* is the part number), the performance is a "single performance," so hold down [SHIFT] and press [SOLO] to change to a layer performance.
- * *The setting here is linked to the Key Mode parameter (PERFORM/COMMON/PERFORM COMMON).*
3. Press the function button for the part that you wish to play, to make the indicator light. When the [1-8/9-16] indicator is dark, parts 1-8 can be selected, and when the [1-8/9-16] indicator is lit, parts 9-16 can be selected. The Local parameter of the selected part will be ON.
- * *This setting is linked with the Local parameter (PERFORM/MIDI/MIDI).*
4. Repeat step 3 to turn the Local parameter ON for each part that you wish to play.

■ Splitting the Keyboard to Play Separate Patches in Different Sections (Split)

If you've selected a Layer Performance, you can split the keyboard to play separate Patches with different sections of the keyboard. As the note range that plays each Part can be specified individually, you can split the keyboard into a maximum of 16 sections.

For instance, you can play strings in the lower note section, piano in the higher note section and both sounds in the middle note section.

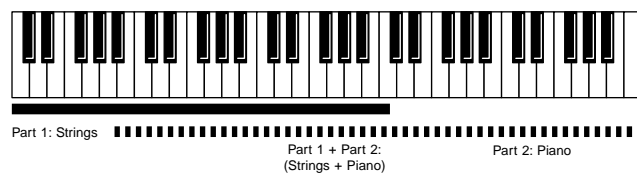

- * *If a KEY RANG display (PATCH/COMMON) has been set, sounds are produced in the overlapping sections between the key ranges specified for the Patch and Performance.*
1. Make sure that the PERFORM PLAY display is showing.
 2. Make sure that the upper right of the display indicates "LAYER p*" (* is the part number). If the display indicates "part=*" (* is the part number), the performance is a "single performance," so hold down [SHIFT] and press [SOLO] to change to a layer performance.
- * *The setting here is linked to the Key Mode parameter (PERFORM/COMMON/PERFORM COMMON).*
3. Press the function button for the part that you wish to play, to make the indicator light. When the [1-8/9-16] indicator is dark, parts 1-8 can be selected, and when the [1-8/9-16] indicator is lit, parts 9-16 can be selected. The Local parameter of the selected part will be ON.
- * *This setting is linked with the Local parameter (PERFORM/MIDI/MIDI).*
4. Repeat step 3 to turn the Local parameter ON for each part that you wish to play.
 5. Press [EDIT] to make the indicator light. Then press the [COMMON] function button, and press [▲] or [▼] to access the PERFORM COMMON display.

- Make sure that the Key Range parameter is ON. If it is OFF, use the cursor buttons to move the cursor to the Key Range parameter, and rotate the VALUE dial or press [INC]/[DEC] to turn it ON.
- If the Key Range parameter is OFF, the keyboard cannot be split even when you set the key range.*
- Press [▼] to access the KEY RANG display.

```
PART 1↑          Lower |          Upper
KEY RANG↓      C 3|          C 4
```

- Press [EDIT] to make the indicator go dark.
- Press a function button to select the part whose Local parameter you wish to turn ON. When the [1-8/9-16] indicator is dark, you can select parts 1-8. When the [1-8/9-16] indicator is lit, you can select parts 9-16.
- Specify the range of notes for which the part will sound. Use the cursor buttons to move the cursor to the Lower parameter and set the lowest note of the range. Move the cursor to the Upper parameter and set the highest note of the range.
- Rotate the VALUE dial or press [INC]/[DEC] to specify the range of notes.
- By specifying sections for different Parts so that they overlap each other, you can combine two or more Patches only in a specific section.*
- When you are finished making settings, press [EXIT] to return to the PERFORM PLAY display, and begin playing.

■ Playing Along with a Song Playback (XP-30 Used as a Multitimbral Sound Source)

When a Single Performance is selected, the XP-30's keyboard will play only the Part you selected from the keyboard, convenient when you play the keyboard along with a song playback.

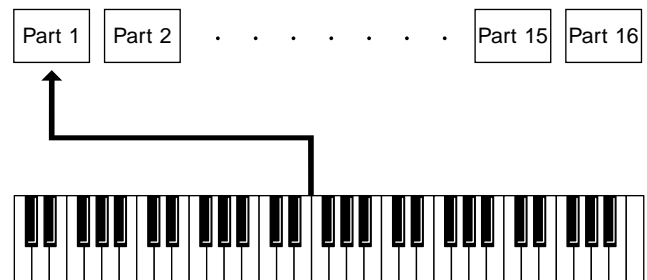

Selecting a Part You Want to Play on the Keyboard

If a Single Performance is selected, press [◀] or [▶] to select the Part you want to play. The selected Part is called the **Current Part**.

- Make sure that the PERFORM PLAY display is showing.
- Press [◀] or [▶] to choose the Part to be played. The part number shown in the upper right of the display will change.

```
PERFORM PR-A: 01 House Set      Part= 1
PLAY                             center=C 4
```

- You can also press a function button to select the part that you wish to play. At this time, the function button indicator of the selected part will light.*

Muting a Specific Part (Turning Receive Channel On/Off)

While you play along with the playback of a song, you can turn on/off any specific Part. This allows you to turn off the melody Part for karaoke applications or for practicing the muted Part.

- Make sure that [EDIT] indicator is dark. If it is lit, press [EDIT] to turn it off. At this time, the function button indicators will indicate the on/off status of each Part. When [1-8/9-16] indicator is dark, the function button indicators will indicate the status of Parts 1-8. When [1-8/9-16] indicator is lit, the function button indicators will indicate the status of Parts 9-16. Lit is on, and dark is off.
 - Hold down [SHIFT] and press the function button to switch Parts on/off.
- This setting is linked with the Rx parameter (PERFORM/MIDI/MIDI).*

■ Assigning a Different Patch to a Part

The Patch assigned to each Part can be stored as a Performance parameter.

1. Make sure that the PERFORM PLAY display is showing.
2. Press [◀] or [▶] to choose the Part to which you want to assign a different Patch.
3. While holding down [PERFORM], press [PATCH] to call up the PLAY display (PART PLAY) of the Patch assigned to a specific Part.

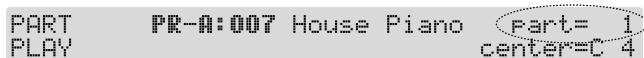

PART PR-A:007 House Piano part= 1
PLAY center=C 4

The upper right of the display will indicate the number of the currently selected part (the current part).

4. Use the same procedure as in Patch mode to select a Patch (p. 47).
- * *This setting is linked with the Group parameter and Number parameter (PERFORM/PART/PATCH).*
5. Press [PERFORM] or [EXIT] to return to the PERFORM PLAY display.

■ Using the Sliders to Modify the Sound in Realtime (Sound Palette Function)

Using the **Sound Palette function**, you can modify sound characters of the Patch assigned to a Part or adjust the volume level of each Part.

- * *Sound variations or volume changes made with the Sound Palette function affect only the performance. They have no effect on the currently selected Performance, so the Sound Palette settings cannot be saved. If you change the Performance, these settings will be lost.*
- * *The sound character and volume changes created using the Sound Palette will also be transmitted to the external MIDI devices.*

Changing Sound Characters

- * *If Single Performance is selected, the effect applies only to the current Part. With Layer Performance selected, this affects only the Parts with Local parameter (PERFORM/MIDI/MIDI) set ON.*

1. Make sure that the PERFORM PLAY display is showing.
2. Press [FILTER/ENV] to light its indicator.

3. Move the sliders while you play the XP-30's keyboard to vary the sound.

To change brightness, move the CUTOFF slider.

To change resonance, move the RESO slider.

To change attack time, move the ATTACK slider.

To change decay time, move the DECAY slider.

Changing the Level (Volume) of Each Part

1. Make sure that the PERFORM PLAY display is showing.
2. Press [LEVEL] to light its indicator.
3. Press [◀] or [▶] to select the Part whose level (volume) you want to change.

If you've selected any of Parts 1–4, sliders 1, 2, 3, and 4 adjust Parts 1, 2, 3, and 4, respectively.

If you've selected any of Parts 5–8, sliders 1, 2, 3, and 4 adjust Parts 5, 6, 7, and 8, respectively.

If you've selected any of Parts 9–12, sliders 1, 2, 3, and 4 adjust Parts 9, 10, 11, and 12, respectively.

If you've selected any of Parts 13–16, sliders 1, 2, 3, and 4 adjust Parts 13, 14, 15, and 16, respectively.

4. Move the slider as you play to adjust the level (volume) of each Part as desired.

Playing in Rhythm Set Mode

In Rhythm Set mode, you can play percussion instruments (Rhythm Tones) on the keyboard. As the Rhythm Tone assigned to each key varies by the Rhythm Set selected, you can play a wide range of percussion instruments.

■ Selecting a Rhythm Set

The XP-30 contains a total of twelve rhythm sets, organized into six groups (User and Preset A–E) with two rhythm sets in each group. In addition, the rhythm sets of two popular Wave Expansion Boards (“Session” and “Techno Collection”) are onboard. Furthermore, you can install up to two separately sold Wave Expansion Boards, giving you access to an even larger number of percussion instruments.

USER

The XP-30’s user memory contains two Rhythm Sets that can be rewritten to make up your own Rhythm Sets.

PR-A–C, E (Preset A–C, E)

The XP-30 includes eight preset Rhythm Sets that are not user-rewritable. But you can call up preset Rhythm Set settings into the temporary area, modify them, and then store them in user memory.

PR-D (GM (General MIDI))

GM Rhythm Sets are for instruments compatible with the General MIDI System intended to standardize MIDI specifications among different equipment makers or models. The XP-30 offers two GM Rhythm Sets that are not user-rewritable. But you can call up GM Rhythm Set settings into the temporary area, modify them, and then store them in user memory.

XP-A and C (Internal Wave Expansion)

The rhythm sets of two Wave Expansion Boards (16 rhythm sets) are already built-in, and cannot be rewritten. However, you can modify the settings of the currently selected rhythm set, and then save the modified settings in User memory.

XP-D, E (Wave Expansion Boards installed in EXP-D, E Slots)

These Rhythm Sets are included in optional Wave Expansion Boards and are not user-rewritable. But you can call up Rhythm Set settings into the temporary area, modify them, and then store them in user memory.

* A Patch XP-D, E cannot be accessed if the Wave Expansion Board it belongs to has not been installed.

1. Press [RHYTHM] to call up the RHYTHM PLAY display.

```

Rhythm Set number
Rhythm Set group | Rhythm Set name
RHYTHM PR-A:002 PopDrumSet 2
PLAY B 1(Hybrid Kick1)center=C 4
  
```

2. Rotate the VALUE dial or press [INC]/[DEC] to select a Rhythm Set.

* Here, pressing [0] (on the numeric key) while holding down [CATEGORY] takes you to the display shown below, where you can verify the total number of selectable Rhythm Sets (a), and the number within the sequence of the currently selected Rhythm Set (b), and choose a Rhythm Set.

```

RHYTHM Rhythm&SFX Drums
INFO PR-A:002 PopDrumSet 2 4/28
                                     (b) (a)
  
```

Selecting a Rhythm Set Using Numeric Keys

Using numeric keys, you can direct input a desired Rhythm Set.

1. Press [RHYTHM] to call up the RHYTHM PLAY display.
2. Press the following buttons to select a Rhythm Set group.

Button	Rhythm Set Group
[SHIFT] + [1]	PR-A (Preset A)
[SHIFT] + [2]	PR-B (Preset B)
[SHIFT] + [3]	PR-C (Preset C)
[SHIFT] + [4]	PR-D (GM (General MIDI))
[SHIFT] + [5]	PR-E (Preset E)
[SHIFT] + [6]	USER (User)
[EXP A]	XP-A (“Session”)
[EXP C]	XP-C (“Techno Collection”)
[EXP D]	XP-D (Wave Expansion Board D)
[EXP E]	XP-E (Wave Expansion Board E)

3. Use numeric keys to input a Rhythm Set number. The rhythm set number and name will blink. At this point the Rhythm Set has not yet been finalized.

4. Press [ENTER] to finalize the entry.

* Using Digit Hold, a Rhythm Set can be selected simply by specifying the 1’s place number (p. 48).

■ Playing Percussion Instruments

1. Press [RHYTHM] to call up the RHYTHM PLAY display.
2. Select a desired Rhythm Set.
3. Press a key on the keyboard to play a percussion instrument.

The key (Note name) you press and its percussion instrument name (Rhythm Tone name, the same as the Wave it uses) will be displayed below the Rhythm Set name.

```
RHYTHM PR-A:002 PopDrumSet 2
PLAY C 2(Round Kick )center=C 4
```

| |
Note name Rhythm Tone name

You can also use the TONE SELECT buttons to select the displayed key.

[TONE SELECT 1]: move to an octave lower key

[TONE SELECT 2]: move to the semitone below

[TONE SELECT 3]: move to the semitone above

[TONE SELECT 4]: move to an octave higher key

- * *When you want to play the percussive instrument sound assigned to the B1 key, first push [-OCT] once, then press the B2 key. Similarly, push [+OCT] once then press the C#6 or D6 key to play the percussive instrument sound assigned to the C#7 or D7 key. (On the XP-30, the leftmost white key is C2, and rightmost white key is C7.)*

For details, refer to “**Transposing the Keyboard in Octave Units (Octave Shift)**” (p. 59).

Playing an Arpeggio

The XP-30’s **Arpeggiator** lets you produce an arpeggio (broken chord) simply by playing a chord. In addition to normal arpeggios, you can also accurately simulate guitar cutting or strumming techniques depending on the Arpeggiator settings. The Arpeggiator can in fact be used as a handy automatic arranger.

By pressing [ARPEGGIO], the indicator lights and allows playing arpeggios from the XP-30 keyboard.

- * *If you press [ARPEGGIO] to turn this function on when Single Performance is selected, the current Part will play arpeggios. When a Layer Performance is selected, an arpeggio will sound for the Part specified by the Part parameter (SYSTEM/ARPEGGIO/ARPEGGIO).*

- * *The arpeggios played by the arpeggiator are also transmitted from the MIDI OUT connector to external MIDI devices.*

1. Make sure that the PLAY display of the sound source mode (PERFORM, PATCH, RHYTHM, GM) is displayed.
2. Press [ARPEGGIO] to turn the Arpeggiator on.
3. If you wish to change how the arpeggio is played, hold down [ARPEGGIO] to access the ARP SELECT display, move the cursor to the Style parameter, and change the setting.

```
ARP     |                      Style|Accent|Oct|Tempo
SELECT|                      1/16| 20%| 0| 120
```

- * *The selection you make here will also affect the Style parameter (SYSTEM/ARPEGGIO/ARPEGGIO) settings.*

There are 43 arpeggio styles available. For selection, refer to the following guideline.

Playing an Arpeggio According to the Timing Interval of a Note

1/4–1/32

Playing a Glissando

GLISSANDO

Playing a Bass Part

SYNTH BASS, SLAP BASS A, SLAP BASS B, WALK BASS

Playing a Guitar

RHYTHM GTR A, RHYTHM GTR B, RHYTHM GTR C,
RHYTHM GTR D, RHYTHM GTR E, 3FINGER GTR,
STRUMMING GTR

Playing a Keyboard Instrument

KBD COMPING A, KBD COMPING B

Playing a Waltz

KBD COMPING C, KBD COMPING D

Playing in Reggae Style

KBD COMPING E

Playing Percussion Instruments

PERCUSSION

* There are also other styles besides the above, including those used for random play and for creating your own styles. For details regarding each style, refer to “**Arpeggio Settings (ARPEGGIO)**” (p. 108).

- To change the “groove” feel of the arpeggio, hold down [ARPEGGIO] to access the ARP SELECT display, move the cursor to the Accent parameter, and change the setting.

```
ARP SELECT | Style | Accent | Oct | Tempo
           | 1/16 | 20% | 0 | 120
```

A setting of 100% will produce the most pronounced groove feel.

* This setting will also affect the Accent Rate parameter (SYSTEM/ARPEGGIO/ARPEGGIO) settings.

- To change the range in which the arpeggio is played, hold down [ARPEGGIO] to access the ARP SELECT display, move the cursor to the Oct parameter, and change the setting.

```
ARP SELECT | Style | Accent | Oct | Tempo
           | 1/16 | 20% | 0 | 120
```

If you want the arpeggio to sound using only the notes that you actually play, set this to 0. With a +1 setting, arpeggio will take place over a range up to 1 octave higher than the notes you play. A -1 setting will result in arpeggio occurring over the range down to 1 octave lower than the notes you play.

* This setting will also affect the Octave Range parameter (SYSTEM/ARPEGGIO/ARPEGGIO) settings.

- To change the tempo in which the arpeggio is played, hold down [ARPEGGIO] to access the ARP SELECT display, move the cursor to the Tempo parameter, and change the setting.

```
ARP SELECT | Style | Accent | Oct | Tempo
           | 1/16 | 20% | 0 | 120
```

* This setting will also affect the Tempo parameter (SYSTEM/ARPEGGIO/ARPEGGIO) settings.

- Play a chord to produce an arpeggio.
 - To stop the arpeggio, press [ARPEGGIO] to turn off the indicator.
- * If you hold down [SHIFT] when you press [ARPEGGIO], the ARP SELECT display will continue being displayed, without you having to hold down [ARPEGGIO]. To go back to the previous display, press [EXIT].

Playing an Arpeggio Over a Preset Keyboard Area

As soon as you press [ARPEGGIO] to turn the Arpeggiator on, the keyboard will be set to play arpeggios so conventional keyboard playing is no longer possible.

If you split the keyboard into two different areas, you can use one area for normal playing and the other for playing arpeggios. This setting, for instance, allows you to play arpeggios with the left hand and a melody with the right hand.

- Press [PERFORM] to call up the PERFORM PLAY display.
- If you have selected a Single Performance, set the Key Mode parameter (PERFORM/COMMON/PREFROM COMMON) to LAYER (p. 52).
- Make sure that the Key Range parameter (PERFORM/COMMON/PERFORM COMMON) is ON. If it is OFF, turn it ON (p. 53).
- Set the Local parameter (PERFORM/MIDI/MIDI) ON for the Part you want to hear (p. 52).
- After pressing [SYSTEM] to make the indicator light up, press the [ARPEGGIO] function button followed by [▼] to display an Arpeggio screen like the one shown below.

```
ARPEGGIO | Key Velocity | Part | Tempo(=SYS)
          | REAL | 1 | 120
```

- Use the cursor buttons to move the cursor to the Part parameter.
 - Rotate the VALUE dial or press [INC]/[DEC] to set the part that will play the arpeggio.
 - Set the Lower or Upper parameter (PERFORM/COMMON/KEY RANG) to specify the note range of the part that will play the arpeggio (p. 53).
 - Set the key range of parts other than the arpeggio part so that they do not overlap the range in which the arpeggio is played.
 - After you finish settings, press [EXIT] to call up the PERFORM PLAY display again and play a chord.
- * If you play an arpeggio using Layer Performance but without setting key range, the chords will sound for all Parts except for the specified Part.

■ Holding an Arpeggio

If you hold down [ARPEGGIO] and press [TRANSPOSE], and get the indicator to start blinking, the arpeggio will continue to be played even if you release the chord.

1. Hold down [ARPEGGIO] and press [TRANSPOSE] to make the indicator blink.
2. Play a chord.
3. If you play a different chord or notes while the arpeggio is being held, the arpeggio will change accordingly.
4. To cancel Arpeggio Hold, hold down [ARPEGGIO] and press [TRANSPOSE] simultaneously once again.

Using a Hold Pedal

If you play an arpeggio while pressing the hold pedal, the arpeggio will continue to be played even if you release the chord.

1. Connect an optional pedal switch to the HOLD PEDAL jack.
2. Play a chord while pressing the hold pedal.
3. To play another chord, release the pedal, press it again as you play the next chord.

■ Simulating a Guitar Cutting Technique

You can simulate a guitar cutting technique by following the procedure below. By using the Sound Palette, it is also possible to apply a wah effect as you play.

1. Select a guitar Patch.
2. Set the Style parameter (SYSTEM/ARPEGGIO/ARPEGGIO) to RHYTHM GTR B, RHYTHM GTR C, RHYTHM GTR D or RHYTHM GTR E.
3. Press [FILTER/ENV] so the indicator lights.
4. Move the CUTOFF slider or RESO slider while you play a chord.

■ Playing an Arpeggio from an External MIDI Device

The XP-30 can also produce arpeggios with incoming Note messages from an external MIDI device.

1. Connect the XP-30's MIDI IN connector and the MIDI OUT connector of an external MIDI device with a MIDI cable.
2. Press [PERFORM] to call up the PERFORM PLAY display.
3. Press [SYSTEM] to make the indicator lit, press the [MIDI] function button, and then press [▲] to access the PERFORM MIDI display.

```
PERFORM Control Channel | Local | Remote  
MIDI      |          16 |  ON |  OFF
```

4. Use the cursor buttons to move the cursor to the Remote parameter.
5. Rotate the VALUE dial or press [INC]/[DEC] to turn the setting ON.
6. Play the external MIDI device.

■ Creating an Arpeggio Pattern

There are a total of 9 parameters that can be set for the Arpeggiator, but the most important is the Style parameter setting. The arpeggio pattern is largely determined by this setting.

When you set the Style parameter, the Motif, Beat Pattern, Accent Rate and Shuffle Rate parameters will automatically be set to optimum settings. After selecting the style, you can also set Octave Range and Key Velocity parameters, etc. If this selection does not provide the pattern you want, modify the settings of the Motif, Beat Pattern, Accent Rate and Shuffle Rate parameters to add variations to the style as desired.

- * Motif, Beat Pattern, Accent Rate and Shuffle Rate settings will be lost if you select another style and then turn the power off.
- * The values you can set with the Motif or Beat Pattern parameters are normally limited by the selected style. Only when the Style parameter is set to LIMITLESS will all values be acceptable.

1. Press [SYSTEM] to make the indicator lit, and then press the [ARPEGGIO] function button to access the ARPEGGIO display.

```
ARPEGGIO | Style | Octave Range
          | 1/2 | 0
```

- * For details regarding each parameter, refer to “*Arpeggio Settings (ARPEGGIO)*” (p. 108)
2. Move the cursor to “Style” and specify the style you want.
 3. Move the cursor to “Octave Range” and specify the key range over which you want arpeggio.
 4. Press [▼], move the cursor to “Motif,” and specify the order in which the notes of the chord will be sounded.
- * The available choices depend on the Style parameter setting. For details, refer to “*Arpeggio Style List*” (p. 182).
5. Move the cursor to “Beat Pattern” to change the beat (rhythm).
- * The available choices depend on the Style parameter setting. For details, refer to “*Arpeggio Style List*” (p. 182).
6. Press [▼], move the cursor to “Accent Rate,” and specify the groove ratio.
A 100% setting will result in the most pronounced “groove” feel.
 7. Move the cursor to “Shuffle Rate” and specify the swing rate.
With a setting of 50%, the notes will be spaced evenly. As the value increases, the note timing will have more of a “swing” feel.
 8. Press [▼], move the cursor to “Key Velocity,” and specify the strength with which the notes of the chord will be sounded.
Move the cursor to “Key Velocity” and specify the force of the chord.
When REAL is selected, the velocity at which the notes are actually played will be used. With a setting of 1–127, the specified velocity value will be used regardless of the force with which you play the chord.
 9. If you want to play an arpeggio using Layer Performance, move the cursor to “Part” and specify the Part for which you want arpeggio.
- * Parts other than that specified here will not sound as arpeggios, and the notes of the chord will sound as you play.
10. Move the cursor to “Tempo” and specify the speed of an arpeggio.
 11. After you finish settings, press [EXIT].

Convenient Functions for Performance

■ Transposing the Keyboard in Octave Units (Octave Shift)

The **Octave Shift** function transposes the pitch of the keyboard in 1 octave units (-3– +3 octaves).

For playing a bass part more easily using your right hand, transpose the keyboard down by 1 or 2 octaves.

1. Press [+OCT] or [-OCT] and its indicator will light. Pressing [+OCT] once will raise the keyboard 1 octave and pressing [-OCT] once will lower it 1 octave. The specified Octave Shift setting will be shown in the “center=C4” indication of each Play screen. For example if you press [+OCT] once to raise the keyboard one octave, the display will indicate “center=C5.” This means that when you press the C4 key, the C5 note will sound.

```
PATCH USER:001 Temple of XP
PLAY center=C 4
```

- * There is only one Octave Shift setting in the XP-30 so it remains valid even if you select a different Patch, Performance or Rhythm Set or turn power off.
2. To turn off the Octave Shift function, press the other button [+OCT] or [-OCT] of that pressed in step 1 the same number of times. The indicator will go off.

■ Transposing the Keyboard in Semitone Steps (Transpose)

Transpose changes keyboard pitch in units of semitones (-5-+6 semitones).

This function is useful when you play transposed instruments such as trumpet or clarinet following a printed score.

1. Press [TRANSPOSE] to light indicator.

This turns Transpose on.

2. While holding down [TRANSPOSE], press [+OCT] or [-OCT] to transpose the keyboard.

Pressing [+OCT] once while holding down [TRANSPOSE] will raise the keyboard one semitone. Pressing [-OCT] once while holding down [TRANSPOSE] will lower the keyboard one semitone.

The specified Transpose setting will be added to the Octave Shift value. For example, if you hold down [TRANSPOSE] and press [+OCT] once to raise the keyboard a semitone, the display will indicate "center=C#4." So when C4 is pressed, the C#4 note will sound.

3. To turn off Transpose, press [TRANSPOSE] once again so that its indicator goes off.

The Transpose setting you make will be maintained.

- * *The Transpose setting you make here will also change the Transpose parameter (SYSTEM/CONTROL/KEYBOARD).*
- * *The setting you make will be maintained even if you select a different Patch, Performance or Rhythm Set, or turn the power off.*

■ If "Stuck" Notes Occur or a Note Does Not Sound (Panic)

If a note played on the XP-30 or from an external device "locks" or keeps sounding and you can't shut it off, hit the Panic button. Do the same if a note does not sound.

When "Stuck" Notes Occur

1. Hold down [SHIFT] and press [EXIT].
MIDI messages for Note Off and Hold Off will be transmitted to the Parts (MIDI channels) receiving Note On/Hold On messages.
2. The display will indicate "Panic! Now Muting." while the Panic function is being executed. When this message goes off, you can start playing.

When a Note Does Not Sound

1. Hold down [SHIFT] and press [EXIT] for more than a second.
MIDI messages for Volume (127), All Note Off, Pitch Bend (center), Channel Aftertouch (0), Modulation (0), and Hold 1 (0) will be transmitted to all Parts (MIDI channels).
2. The display will indicate "Panic! Now Transmitting." while the Panic function is being executed. When this message goes off, you can start playing.

Chapter 3. Creating Your Own Sounds

Regarding Effects

The XP-30 contains three independent effects units.

Multi-Effects (EFX)

The Multi-Effects offers 40 different effects ranging from single effects such as distortion and delay to powerful combination effects. The Multi-Effects also includes chorus and reverb effects which are independent of the Chorus and Reverb outlined below.

Chorus

Chorus adds depth and spaciousness to the sound.

Reverb

Reverb adds reverberation characteristics of hall or auditorium ambiences.

Connection of the three effects units depend on the mode you've selected.

How Effects Units Work in Different Modes

In Patch Mode

The Multi-Effects, Chorus and Reverb effects can be set individually for each Patch. Adjusting the signal level to be sent to each effects unit (Send Level) provides control over the effect intensity that's applied to each Tone.

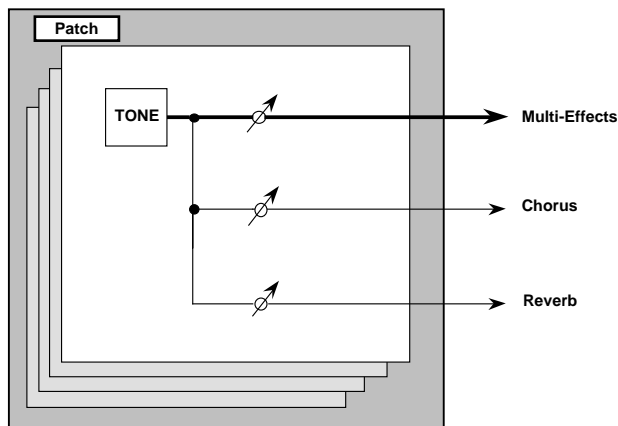

In Performance Mode/GM Mode

The Multi-Effects, Chorus and Reverb effects can be set individually for each Performance and GM mode. The intensity of each effect will be set for each Part (Fig. 1), but the Send Level setting for each Tone can also influence effect intensity (Fig. 2). Effects settings of the Patch assigned to each Part will be ignored, but Multi-Effects applied to a Patch assigned to a given Part can also be applied to the entire Performance.

Fig.1 – When Output Assign is set to “EFX” in the Performance mode (the output settings for Tone are ignored)

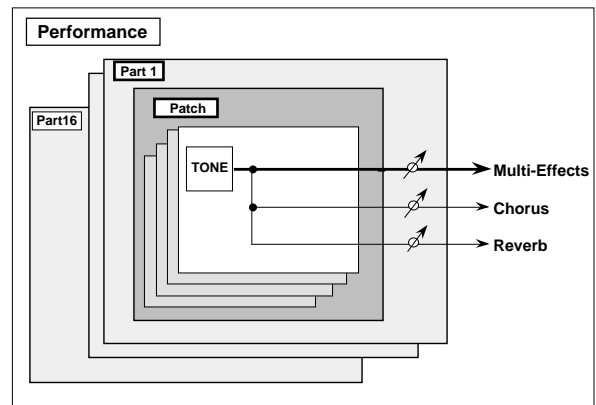
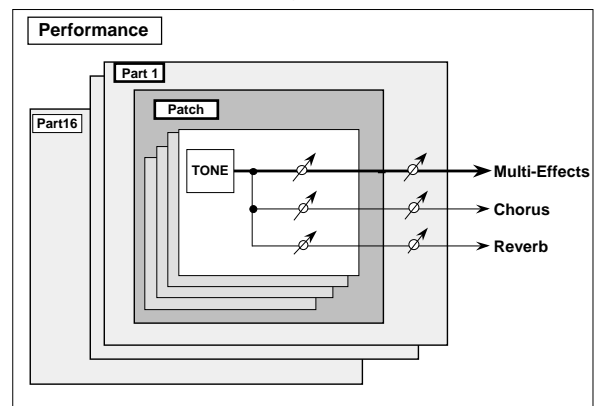

Fig.2 – When Output Assign is set to “PATCH” in the Performance mode (the output settings for Tone are valid)



In Rhythm Set Mode

Because in Rhythm Set mode, only Part 10 of a Performance is called up, the effects settings of a Performance in the temporary area will be used.

■ Turning Effects On/Off

Built-in effects units (Multi-Effects, Chorus and Reverb) can be turned on/off for the XP-30 as a whole. Turn them off if you want to edit sound while listening to the original sound or if you want to use external effects units.

1. Press [EFFECTS ON/OFF] to call up the EFFECTS ON/OFF display.

```
EFFECTS | EFX | Chorus | Reverb
ON/OFF  | ON  | ON    | ON
```

2. Press [◀] or [▶] to move the cursor to the effect that you wish to modify.
3. Rotate the VALUE dial or press [INC]/[DEC] to switch it on/off.
4. When you finish making settings, press [EFFECTS ON/OFF] or [EXIT] to return to the previous display.

* *When the EFX (multi-effects), Chorus, and Reverb processors are all off, the [EFFECTS ON/OFF] indicator goes out, showing that the onboard effects processors are not used.*

Sound Editing Procedures

With the XP-30, you have total control over various settings. Each item to be set is a parameter. Editing refers to modifying any parameter value. This section goes over editing procedures for Patches, Performances and Rhythm Sets.

■ Editing a Patch

Start by editing a preexisting Patch to create a new one. Since a Patch is a combination of up to any four Tones, you should listen to how the individual Tones sound before you edit.

Four Tips for Editing Patches

Start with a Patch that's somewhat familiar sounding

It's hard to create a new sound that's exactly what you want if you just select a Patch and modify its parameters at random. It makes sense to start with a Patch whose sound is related to what you have in mind.

Deciding on the Tone to use

When creating a Patch, deciding on the Tones you'll use is crucial. For each Tone, use the TONE SWITCH [1]–[4] to decide whether to turn it on (have it sound) or off. Turn off Tones you don't need to avoid using more voices than required. A Tone switches on/off each time its respective button is pressed. When a Tone's indicator lights, it'll sound.

Check the Structure setting

The important Type parameter (PATCH/COMMON/STRUCT) determines how the four Tones combine. Before editing Tones, make sure you really understand how they work together.

Turn off effects

Since XP-30 effects really influence the sound, turn them off to listen to the sound itself so you can better evaluate the changes you're making. Sometimes just changing effects settings can give you the sound you want.

1. Press [PATCH] to access the PATCH PLAY display, and select the Patch whose settings you wish to modify (p. 47).
2. Press [EDIT] to make the indicator light.
3. Use the function buttons to select the display group. The button indicator of the selected display group will blink.

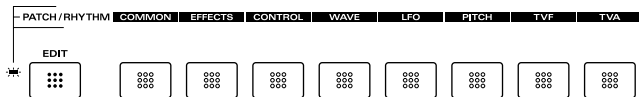

4. Use [▲] or [▼] to select a display page.
5. If you have selected a parameter display that can be set independently for each Tone, the number of the Tone selected for editing will be shown in the display. To select a different Tone, press [EDIT] to temporarily turn off the indicator, and use TONE SELECT [1]-[4] (located in the row of function buttons) to select a Part.

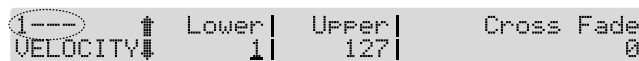

For simultaneously modifying the same parameter for two or more Tones, hold down one of TONE SELECT [1]-[4] buttons and press another TONE SELECT [1]-[4] button, then another if so desired. An asterisk (*) will be indicated for Tones other than the first-selected Tone.

* To switch Tones on/off, turn off [EDIT] indicator and then use the TONE SWITCH [1]-[4] located in the row of function buttons.

6. Use [◀] or [▶] to move the cursor to the parameter you wish to modify.
7. Use the VALUE dial, [INC]/[DEC] or numeric keys and modify the parameter value.
 - * If you've selected two or more Tones, your editing will modify the parameter values for all selected Tones by the same amount.
 - * If you've made a mistake in setting the parameter value or you don't like the changes, just press [UNDO/COMPARE] to restore the value to what it was.
8. If you wish to move to another display group, press [EDIT] to make the indicator light, and use the function buttons.
 - * You can also move to another display group by holding down [SHIFT] and using [◀] or [▶]. Since this can be done even when [EDIT] indicator is dark, it is a faster way to get around because you don't have to turn on [EDIT] indicator each time.
9. Repeat steps 3-8 to complete a Patch.
10. When you finish making settings, press [EXIT] or [PATCH] to return to the PATCH PLAY display.

An asterisk (*) will be displayed at the left of the Patch group. This shows Patch settings have been modified.



* If you select another Patch in the group with an asterisk (*), the modified Patch settings will be lost. If you wish to keep these modified settings, you must write them into user memory (p. 68).

Editing Patches Using the Palette Display

When editing a Tone in a Patch, the parameter values of the four Tones can be displayed together on a single display called the **Palette display**. Use it when you want to modify parameter values as you compare the settings of the four Tones.

1. When modifying a Tone, use [◀] or [▶] to move the cursor to the parameter you wish to modify.
2. Press [PALETTE EDIT] to call up the Palette display.

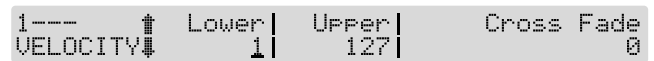

3. Press a TONE SELECT [1]-[4] buttons, [◀] or [▶] to choose the Tone to modify.

The button indicator for the selected Tone will light and the Tone number and Wave name appear in the display.

For modifying the same parameter of two or more Tones simultaneously, hold down one of TONE SELECT [1]-[4] buttons and press another.

4. Use the VALUE dial, [INC]/[DEC] or numeric keys to change the parameter value.

If you've selected two or more Tones, your editing will modify the parameter values for all selected Tones by the same amount.

If you want to set all selected Tones to the same value, select the Tone having that value by pressing [◀] or [▶] and while holding down [SHIFT], press [ENTER].

* If you've made a mistake in setting the parameter value or you don't like the changes, press [UNDO/COMPARE] to restore the value to what it was.

5. If you wish to edit other parameters, press [▲] or [▼] to select the parameter that you wish to edit.
6. Repeat steps 3-5 to complete a Patch.
7. To cancel the palette display, press [PALETTE EDIT] to make the button indicator go dark.

Note on Tone Editing

Because the XP-30 is designed to create wholly realistic sounds, editing necessarily affects the complex PCM waveforms sound are based on. So if you try to create a sound which is totally different from the original waveform, the results may not be what you want. XP-30 waveforms are divided into:

One-Shot: These waveforms contain sounds that have short decays. A one-shot waveform records the initial rise and fall of the sound. Some of the XP-30's one-shot waveforms are sounds that are complete in themselves, such as percussive instrument sounds. The XP-30, however, contains many other one-shot waveforms that are only partial elements of sounds. These include attack components such as piano hammer sounds and guitar fret noises.

Looped: These waveforms contain sounds with long decays or sustained sounds. With looped waveforms, the latter part of the sound is generated repeatedly over a specified portion of the waveform for as long as the note is held (allowing wave memory to be used more efficiently). The XP-30's looped waveforms include such sound components as piano string vibrations and hollow sounds of brass instruments.

The following diagram shows an example of sound (electric organ) that combines one-shot and looped waveforms.

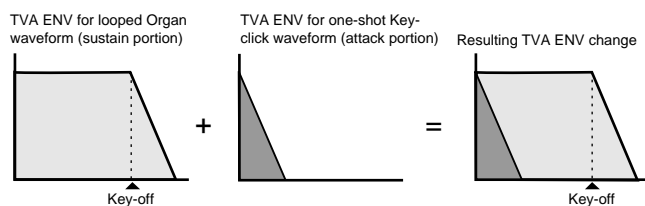

Notes for Editing One-Shot Waveforms

An envelope cannot be used for giving a one-shot waveform a longer decay than the original waveform's, or make it a sustaining sound. Even if you were to make such envelope settings, you would simply be controlling a non-existent portion of the sound, so such settings would have no meaning.

Notes for Editing Looped Waveforms

With many acoustic instruments like piano and sax, radical timbral changes occur during the first few moments of the note. This initial attack is what defines much of the instrument's character. The XP-30 provides a variety of waveforms containing realistic acoustic instrument attacks. To obtain the maximum realism when using these waveforms, it is best to leave the filter wide open during the attack. This way, all the complex timbral changes can be heard. For the decay portion of the sound, you can use the envelope to produce the desired changes. If you use the envelope to modify the attack portion as well, the natural attack contained in the waveform itself will not be heard to full advantage, and you may not achieve the result you want.

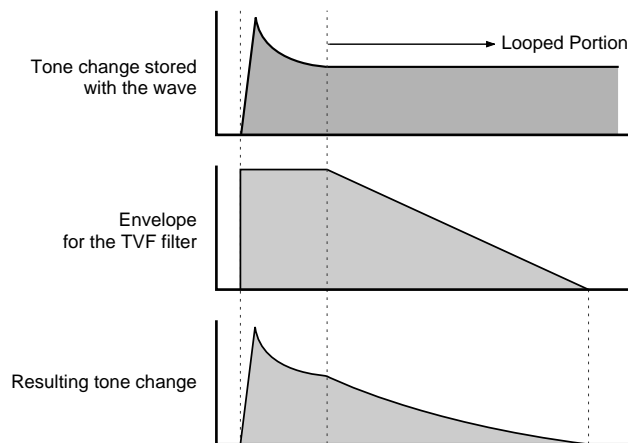

If you try to make just the attack brighter and subdue just the decay using the TVF filter, you need to keep in mind the timbral characters of the original waveform. And particularly if you're making a part of the sound brighter than the original waveform, you should first generate upper harmonics (not present in the original waveform) using Color and Depth parameters (PATCH/WAVE/FXM) before filtering. If you don't, the results will be disappointing. To make the entire sound brighter than the original waveform, try adjusting effects such as enhancer and equalizer before modifying the TVF parameter (PATCH/TVF).

■ Editing a Performance

Start with an existing Performance and edit it to create a new Performance. But before you do, try to envision what the entire Performance will sound like and decide which Patch to assign to each of 16 Parts.

1. Press [PERFORM] to access the PERFORM PLAY display, and select the Performance whose settings you wish to modify (p. 51).
2. Press [EDIT] to make the indicator light.
3. Use the function buttons to select the display group. The button indicator of the selected display group will blink.

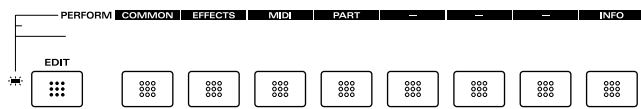

4. Use [▲] or [▼] to select a display page.
5. If you have selected a parameter display that can be set independently for each Part, the number of the Part selected for editing will be shown in the display. To select a different Part, press [EDIT] to temporarily turn off the indicator, and use [1-8/9-16] and the function buttons to select a Part.



6. Use [◀] or [▶] to move the cursor to the parameter you wish to modify.
7. Use the VALUE dial, [INC]/[DEC] or numeric keys and modify the parameter value.
 - * If you've selected two or more Tones, your editing will modify the parameter values for all selected Tones by the same amount.
 - * If you've made a mistake in setting the parameter value or you don't like the changes, just press [UNDO/COMPARE] to restore the value to what it was.
8. If you wish to move to another display group, press [EDIT] to make the indicator light, and use the function buttons.
 - * You can also move to another display group by holding down [SHIFT] and using [◀] or [▶]. Since this can be done even when [EDIT] indicator is dark, it is a faster way to get around because you don't have to turn on [EDIT] indicator each time.
9. Repeat steps 3–8 to complete a Performance.
10. When you finish making settings, press [EXIT] or [PERFORM] to return to the PERFORM PLAY display.

An asterisk (*) will be displayed at the left of the Performance group. This shows Performance settings have been modified.

```
PERFORM *USER: 01 EasternSplit LAYER = 1
PLAY                                center=C 4
```

- * If you select another Performance in the group with an asterisk (*), the modified Performance settings will be lost. If you wish to keep these modified settings, you must write them into user memory (p. 68).

Editing Performance Using the Palette Display

You can also edit a Performance using the Palette display in Performance mode. When modifying Part settings for a Performance, the values for eight Parts (Part 1–8 or Part 9–16) will be displayed together on a single display. This is useful when you wish to change parameter values while comparing each Part settings.

1. When modifying a Part, use [◀] or [▶] to move the cursor to the parameter you wish to modify.
2. Press [PALETTE EDIT] to call up the Palette display.

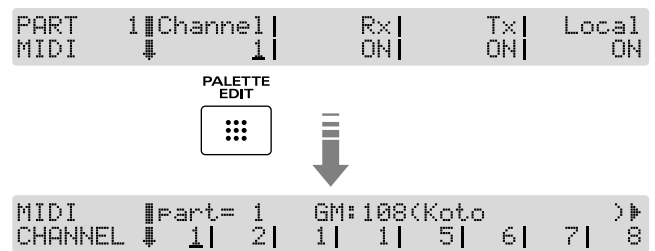

3. Press [◀] or [▶] to choose the Part to modify. The Part number and the Patch name assigned to the Part will be shown in the display.
 - * To switch between the palette page for parts 1–8 and the palette page for parts 9–16, press [1-8/9-16].
4. Use the VALUE dial, [INC]/[DEC] or numeric keys to change the parameter value.
 - * If you've made a mistake in setting the parameter value or you don't like the changes, press [UNDO/COMPARE] to restore the value to what it was.
5. If you wish to edit other parameters, press [▲] or [▼] to select the parameter that you wish to edit.
6. Repeat steps 3–5 to complete a Performance.
7. To cancel the palette display, press [PALETTE EDIT] to make the button indicator go dark.

Modifying the Patch Assigned to a Part

When using Patches in Performance mode, some settings such as effects settings will be affected by Performance settings. If you wish to edit a Patch while hearing how it will sound in the Performance, use this procedure:

1. Make sure that the PERFORM PLAY display is showing.
2. Press [◀] or [▶] to select the Part to which the selected Patch is assigned.
3. While holding down [PERFORM], press [PATCH]. Both button indicators will light. This will call up the PLAY display of the Patch assigned to the currently selected Part.

```
PART      GN:108 Koto      part=  1
PLAY      center=C 4
```

4. The following steps are the same as when you modify a Patch in Patch mode.
 5. When you finish making settings, press [EXIT] to call up the PLAY display of the Patch assigned to the Part. An asterisk (*) will be displayed at the left of the Patch group. This indicates the Patch settings have been modified.
 6. To return to the PERFORM PLAY display, press [PERFORM] or [EXIT].
- * If you select another Patch in the group with an asterisk (*), the modified Patch settings will be lost. To keep these modified settings, you must write them into user memory (p. 68).

■ Editing a Rhythm Set

You can change the percussion instrument assigned to each key. As each percussion instrument consists of a single Rhythm Tone, there is no Palette display.

1. Press [RHYTHM] to access the RHYTHM PLAY display, and select the Rhythm Set whose settings you wish to modify (p. 55).
2. Press [EDIT] to make the indicator light.
3. Use the function buttons to select the display group. The button indicator of the selected display group will blink.

```

┌── PATCH/RHYTHM ─┬── COMMON ─┬── EFFECTS ─┬── CONTROL ─┬── WAVE ─┬── LFO ─┬── PITCH ─┬── TVE ─┬── TVA ─┬──
│
│ EDIT
│ * [grid of 10 buttons]

```

- * Since Rhythm Sets do not have an LFO, it will not be possible to select the LFO group.

4. Use [▲] or [▼] to select a display page.
5. If you have selected a parameter display that can be set independently for each key, the key selected for editing will be shown in the display. To select a different key, play the desired key on the keyboard.

```

B 1  Output Assign| Chorus| Reverb
OUTPUT  MIX:120|  0|  0

```

- * If [EDIT] indicator is turned off, you can also use the TONE SELECT [1]-[4] (located in the row of function buttons) to select the displayed key.
- TONE SELECT [1]: move to an octave lower key
TONE SELECT [2]: move to the semitone below
TONE SELECT [3]: move to the semitone above
TONE SELECT [4]: move to an octave higher key
6. Use [◀] or [▶] to move the cursor to the parameter you wish to modify.
 7. Use the VALUE dial, [INC]/[DEC] or numeric keys and modify the parameter value.
- * If you've made a mistake in setting the parameter value or you don't like the changes, just press [UNDO/COMPARE] to restore the value to what it was.
8. If you wish to move to another display group, press [EDIT] to make the indicator light, and use the function buttons.
- * You can also move to another display group by holding down [SHIFT] and using [◀] or [▶]. Since this can be done even when [EDIT] indicator is dark, it is a faster way to get around because you don't have to turn on [EDIT] indicator each time.
9. Repeat steps 3-8 to complete a Rhythm Set.
 10. When you finish making settings, press [EXIT] or [RHYTHM] to return to the RHYTHM PLAY display. An asterisk (*) will be displayed at the left of the Rhythm Set group. This shows Rhythm Set settings have been modified.

```

RHYTHM *PR-A:002 PopDrumSet 2
PLAY      B 1(Hybrid Kick1)center=C 4

```

- * If you select another Rhythm Set in the group with an asterisk (*), the modified Rhythm Set settings will be lost. If you wish to keep these modified settings, you must write them into user memory (p. 68).

Keeping Edited Sound

■ Memory and Data Storage

The location where Patch and Performance settings, etc. are stored is **Memory**. There are three memory types: temporary memory, rewritable memory and non-rewritable memory.

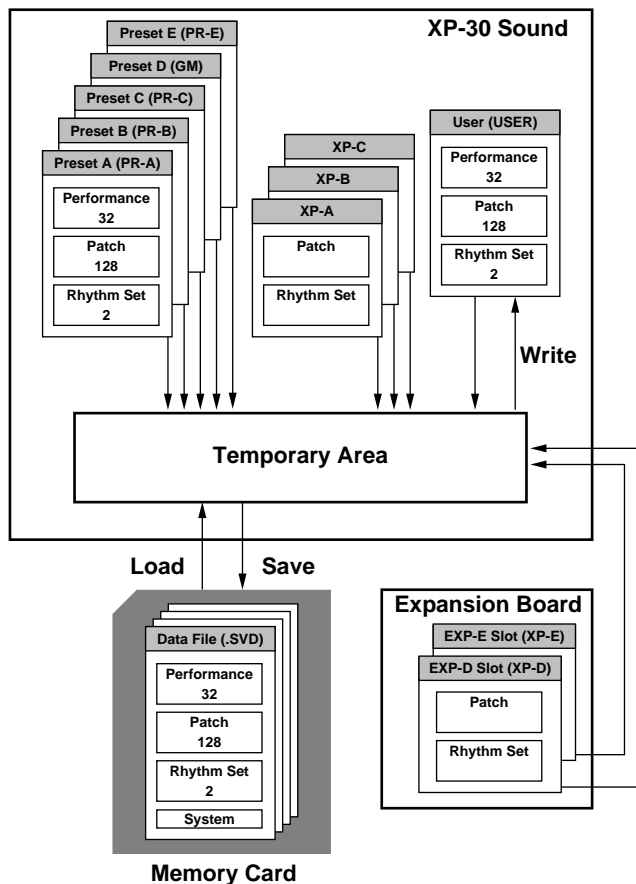

Temporary Memory

Temporary Area

This area holds data for the Performance, Patch, and Rhythm Set you select using the front panel buttons, etc. When you play the keyboard or play back an external sequence, sound is produced based on data in the temporary area. When you modify a Performance, Patch or Rhythm Set, you are modifying the data that has been called into the temporary area instead of the data in memory.

Settings in the temporary area are temporary, and will be lost when the power is turned off or when you select another Performance/Patch/Rhythm Set. To keep the settings you have modified, you must write them into rewritable memory.

Rewritable Memory

System Memory

System memory stores system parameter settings that determine how the XP-30 functions. When you modify these settings, the system memory settings are rewritten directly. These settings are non-volatile, being retained even when the power is turned off.

User Memory

User memory contains data for 32 Performances, 128 Patches and two Rhythm Sets.

Memory Card (optional: SmartMedia)

These are read/write cards which can store data from internal system memory and user memory. You can use memory cards to store data for which there is no room in internal user memory, or data which you wish to use on another XP-30.

Before a memory card can be used, it must be formatted (p. 122).

* Either "S2M-5" or "S4M-5" memory cards can be used.

Memory cards are not included, but may be purchased from your dealer.

Non-Rewritable Memory

Preset Memory

Data in Preset memory (Patch: PR-A-C, E, GM, XP-A-C, Performance: PR-A, B, Rhythm Set: PR-A-C, E, GM, XP-A, C) cannot be rewritten. However, you can call up settings from preset memory into the temporary area, modify them and then store the modified data in rewritable memory.

Wave Expansion Boards (optional: SR-JV80 Series)

Up to four Wave Expansion Boards can be installed in EXP-D, E Slots in the XP-30. Wave Expansion Boards contain Wave data, as well as Patches and Rhythm Sets that use this Wave data, which can be called directly into the temporary area and played.

■ Storing a Sound You Modify into User Memory

The modified settings you make are only temporary, and will be lost if you turn the power off or select another Patch, Performance or Rhythm Set. To keep the modified settings, you must write them into user memory.

1. In Patch mode (when storing a Patch), Performance mode (when storing a Performance) or in Rhythm Set mode (when storing a Rhythm Set), press [UTIL/CARD]. The UTIL 1 display will appear.

```
UTIL 1:WRITE|2:COPY|3:INIT|4:XFER|5:PRO-
 1↓          |          |          |          |          |

```

2. Use [◀] or [▶] to make “1: WRITE” blink. Then press [ENTER].

The WRITE display will appear.

```
PATCH  █Number █[COMPARE]/[ENTER]
WRITE  █User:001(Temple of XP)

```

Writing destination

3. Use the VALUE dial, [INC]/[DEC] or numeric keys to specify the Patch, Performance or Rhythm Set number of the destination of writing.
4. Press [ENTER].
If Internal Write Protect is turned off, the specified writing destination Patch, Performance or Rhythm Set will be overwritten.
5. If Internal Write Protect (p. 121) is turned on, the following display will appear. Change the ON setting to OFF, and press [ENTER]. Internal Write Protect will be turned off, and you will return to the display of step 2. Press [ENTER] once again and the selected Patch will be overwritten.

```
WRITE █ Internal Write Protect= ON
PROTECT █

```

- * Internal Write Protect is automatically turned ON when the XP-30's power is turned on.

Functions of Patch Parameters

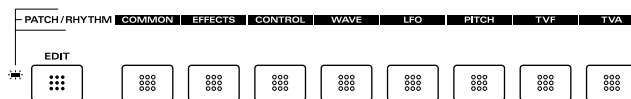

■ Settings Common to the Entire Patch (COMMON)

On this display you can assign a name to a Patch and set the volume and pan of the entire Patch.

PATCH NAME

You can assign a name of up to 12 characters to the Patch.

- * For details on assigning names, refer to “Assigning a Name” (p. 46).

PATCH CATEGORY

Category

Specify the type (category) of the Patch.

The Patch Search function uses this setting. This setting also determines the phrase that will be sounded by the Phrase Preview function.

- * For details on the category names, refer to p. 49.

PATCH CLOCK

Some parameters allow you to set a time value in terms of a note length which is determined by a tempo setting or tempo source you specify; Rate parameters (PATCH/ LFO/ LFO1, 2), Time parameter (PATCH/WAVE/TONE DELAY), and some Multi-Effects parameters. This Patch Clock setting sets the tempo which can be used by these parameters.

- * When using a Patch in Performance mode, the setting of this parameter will be ignored, and the setting of the PERFORM CLOCK display (PERFORM/COMMON) will be used instead.

Source (Patch Clock Source)

Select the source of the Patch Clock.

PATCH: Synchronize to the Patch Tempo setting.

SYSTEM: Synchronize to the tempo clock of the sequencer.

- * The Patch Clock does not transmit clock messages from MIDI OUT connector.

Tempo (Patch Tempo)

Set the Patch Tempo setting.

- * When Source (Patch Clock Source) is set to SYSTEM, synchronization will be according to the tempo clock of the system, so it will not be possible to set the tempo value. The tempo of the system will be displayed in parentheses ().

PATCH COMMON

Level

Adjust the volume level of the Patch.

Pan

Adjust the stereo position of the Patch. A setting of L64 is far left, 0 is center, and 63R is far right.

Analog Feel (Analog Feel Depth)

Adjust the depth at which 1/f modulation is applied to the Patch.

1/f Modulation

“1/f” is a mathematical ratio that expresses the amount of “predictable randomness” occurring in natural sounds that the human ear finds pleasing, such as soft breezes or gentle brooks. The XP-30 is able to modulate the pitch and volume of sounds by this ratio to create the warmth characteristic of early analog synthesizers.

Octave (Octave Shift)

Specify the transposition of the Patch when played on the keyboard, in units of one octave (-3--+3 octaves).

Stretch (Stretch Tuning Depth)

Select the stretch tuning curve. The selected curve will affect the way in which notes of a chord sound with each other. The diagram below shows the tuning curves which can be selected. In the “tuning curve,” the horizontal axis represents the scale, and the vertical axis represents pitch difference relative to equal temperament. When OFF is selected for this parameter, the notes of the keyboard will be in mathematically equal temperament. With a setting of 3, the high and low note ranges will be stretched the most.

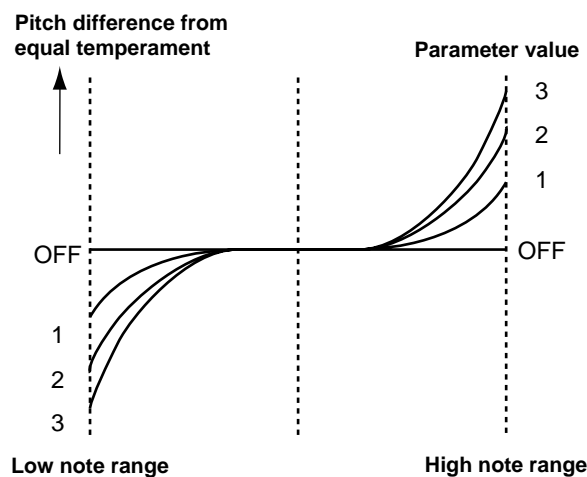

Stretched Tuning

Acoustic pianos are normally tuned so that the high note range is a bit sharper and the low note range is a bit flatter than a mathematically calculated equal temperament (i.e., where each octave would be precisely double the frequency of the previous octave). This is done simply because pianos sound better when tuned this way.

Priority (Voice Priority)

Specify which currently-sounding notes will take priority when notes are turned off to make room for newly-requested notes that would exceed the limit of 64 simultaneous voices.

LAST: Notes played later will take priority. When the 65th voice is requested, the first-played of the currently sounding notes will be turned off.

LOUDEST: Louder notes will take priority. When the 65th voice is requested, the softest of the currently sounding notes will be turned off.

VelRang (Velocity Range Switch)

Specify whether the Velocity Range setting (see following display) will be used or not. The Velocity Range setting will be used when the VelRange parameter is ON.

VELOCITY (Velocity Range)

These parameters specify the range of velocities that will play the Tone. This can be used to make notes of different strengths play different Tones.

* To make Velocity Range settings, the Velocity Range Switch in the previous display must be turned ON.

Lower (Velocity Range Lower)

Specify the lower velocity limit. Although it also depends on the Cross Fade settings, notes played softer than this limit will not sound the Tone, or will produce extremely quiet sounds.

Upper (Velocity Range Upper)

Specify the upper velocity limit. Although it also depends on the Cross Fade settings, notes played more strongly than this limit will not sound the Tone, or will produce extremely quiet sounds.

* It is not possible to set Lower to a value greater than Upper, nor Upper to a value less than Lower. If you attempt to do so, the two values will change together.

Cross Fade (Velocity Cross Fade)

Specify the way in which the volume of the Tone will change when the velocity of a note falls outside of the specified Velocity Range. Higher settings will result in a more gradual change in volume. If you do not want the Tone to sound at all for velocities outside the specified range, set this parameter to 0.

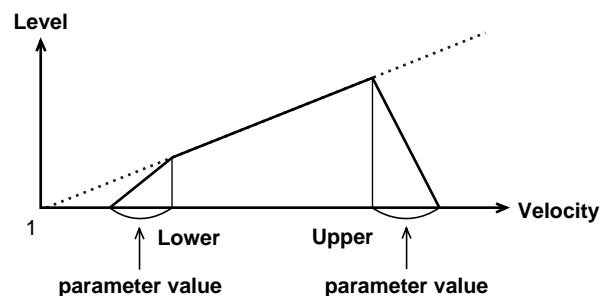

Chapter 3. Creating Your Own Sounds

KEY RANG (Key Range)

These parameters specify the range of notes that will play the Tone. This can be used to make notes in different areas of the keyboard play different Tones.

Lower (Key Range Lower)

Specify the lowest note that will play the Tone.

Upper (Key Range Upper)

Specify the highest note that will play the Tone.

* It is not possible to set Lower to a value greater than Upper, nor Upper to a value less than Lower. If you attempt to do so, the two values will change together.

* If you have used Octave Shift (System) or the Transpose parameter (SYSTEM/CONTROL/KEYBOARD) to transpose the pitch of the XP-30's keyboard, the keyboard area specified by Key Range will also be shifted.

STRUCT (Structure)

Type (Structure Type)

The Structure parameter determines how Tones 1 and 2 (and 3 and 4) are connected.

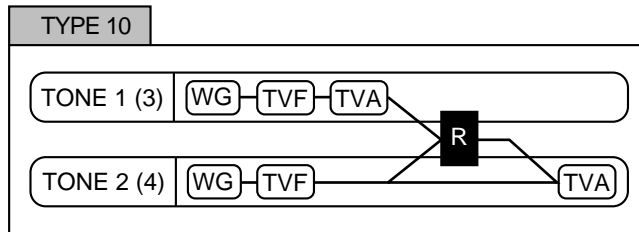
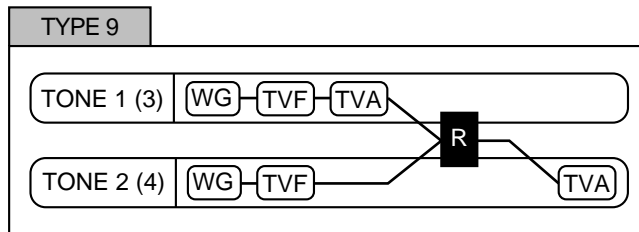
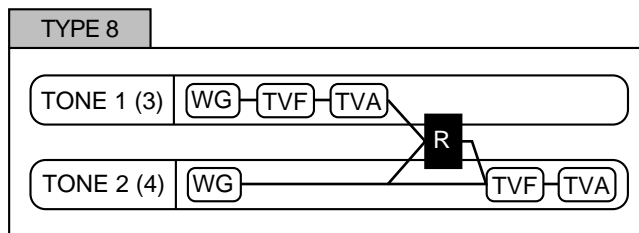
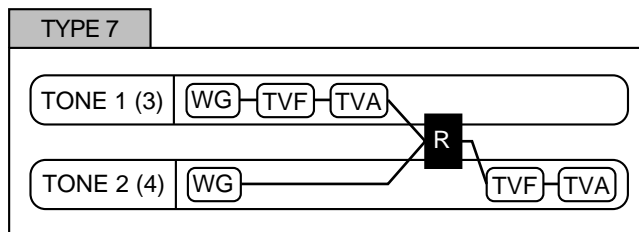
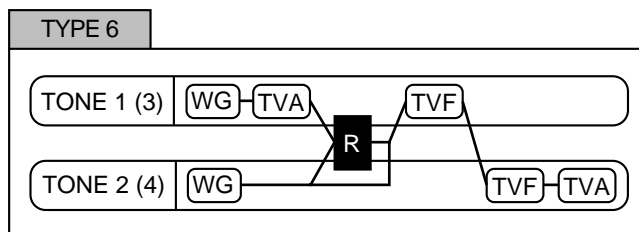
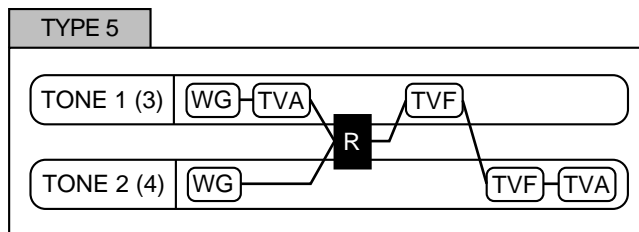
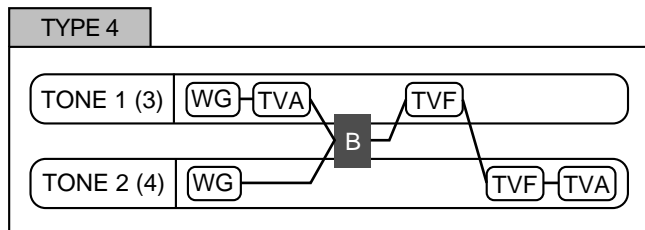
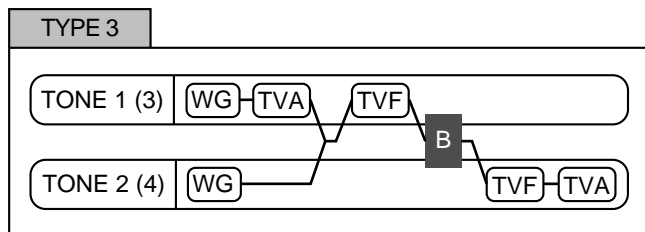
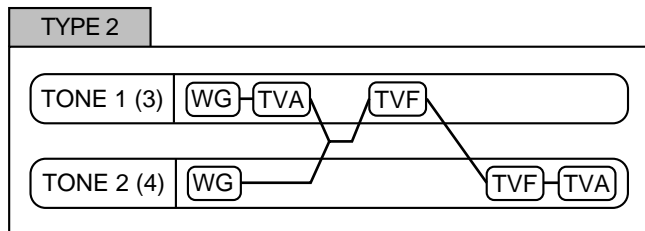
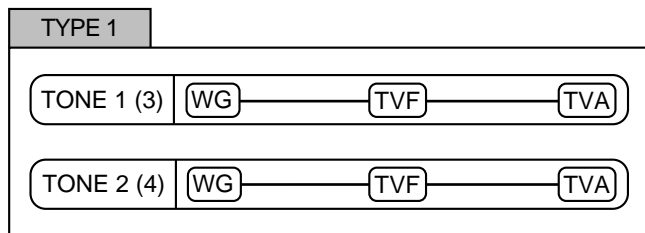

The display will graphically indicate the selected Structure. The symbols displayed have the following meanings. W1 (WG1), W2 (WG2), F1 (TVF1), F2 (TVF2), A1 (TVA1), A2 (TVA2), B (booster), R (ring modulator)

- * If you select a Tone while in the Structure display, the Tone that is paired with the selected Tone will also be selected.
- * If a Structure 2–10 is selected, turning off one Tone will cause the other Tone to be connected in the simple order of WG/TVF/TVA.

Booster (Booster Gain)

If the Type parameter has been set to 3 or 4, you can adjust how strongly the Booster will function. The Booster amplifies the incoming signal, causing it to distort. This creates an effect similar to the distortion often used on an electric guitar.

Ring Modulator

The Ring Modulator multiplies two Tones together, creating a new sound that includes overtones (inharmonic overtones) that were not present in either of the two original Tones. Since the pitch difference between the two Tones will change the overtone structure, the result will be an unpitched metallic sound. This is especially suitable for creating bells and other metallic sounds.

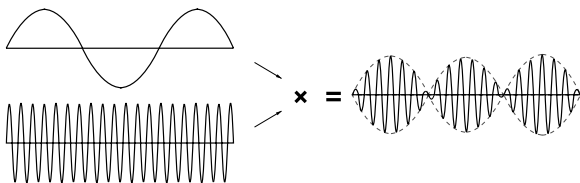

Setting Effects for a Patch (EFFECTS)

This group contains settings for the Multi-Effects/Chorus/Reverb effects used by a Patch.

- * If an “x” mark is displayed at the right of the display name, the effect for that display has been turned off. Turn the corresponding effect on before you make settings (p. 62).

OUTPUT

These parameters specify how the output of each Tone will be sent to the effects.

- * When the Type parameter (PATCH/COMMON/STRUCT) has a setting of 2–10, the outputs of Tones 1 (3) and 2 (4) will be combined with Tone 2 (4). This means that the setting for Tone 1 (3) will be ignored.

Output Assign (Output Assign/Output Level)

Select whether or not the output of each Tone will be sent through Multi-Effects, and adjust the volume of each Tone.

MIX: Output the Tone to the OUTPUT jack without passing through Multi-Effects.

EFX: Output the Tone to the OUTPUT jack through Multi-Effects.

- * If you select MIX, the settings in the PATCH EFX OUT display (PATCH/EFFECTS) will be ignored.

Chorus (Chorus Send Level)

Adjust the amount of Chorus for each Tone.

Reverb (Reverb Send Level)

Adjust the amount of Reverb for each Tone.

PATCH EFX TYPE

Specify the Patch Multi-Effects.

Type (EFX Type)

Select the type of Multi-Effects. For details refer to “Multi-Effects Types (EFX Parameter)” (p. 93).

PATCH EFX PRM (Patch EFX Parameters)

Set the various parameters of the selected EFX type. For details refer to “Multi-Effects Types (EFX Parameter)” (p. 93).

PATCH EFX OUT (Patch EFX Output)

These parameters specify the output for the Tone for which EFX was selected in Output Assign.

* For Tones which have an Output Assign setting of MIX, the settings of this display will be ignored.

Mix Out (EFX Output Level)

Adjust the volume level of the original sound and the Multi-Effects sound.

Chorus (Chorus Send Level)

Adjust the amount of Chorus for the sound that passes through Multi-Effects.

Reverb (Reverb Send Level)

Adjust the amount of Reverb for the sound that passes through Multi-Effects.

PATCH EFX CTRL (Patch EFX Control)

Use this setting when you wish to use a specific controller to control an EFX parameter. The EFX parameters available for control will depend on the selected EFX type. For details refer to “Multi-Effects Types (EFX Parameter)” (p. 93). The upper line of the display will show the EFX parameters that can be controlled. For each EFX parameter, you can specify the EFX Control Source and the EFX Control Depth.

EFX Control Source 1, 2

The following MIDI controllers can be used. If you wish to use a controller that will apply to all Patches, or a controller that cannot be directly specified here, select SYS-CTRL1 or SYS-CTRL2, and then select the controller using the Control 1/2 parameter (SYSTEM/CONTROL/SYS-CTRL ASSIGN).

- OFF:** controller not used
- SYS-CTRL1:** System controller (control 1)
- SYS-CTRL2:** System controller (control 2)
- MODULATION:** Modulation (MIDI controller number 1)
- BREATH:** Breath (MIDI controller number 2)
- FOOT:** Foot (MIDI controller number 4)
- VOLUME:** Volume (MIDI controller number 7)
- PAN:** Pan (MIDI controller number 10)
- EXPRESSION:** Expression (MIDI controller number 11)
- BENDER:** Pitch bend
- AFTERTOUCH:** Aftertouch

EFX Control Depth 1, 2

Adjust the amount of change that will occur in response to controller movements. Higher settings will result in greater change. Negative (-) settings will reverse the direction of change.

PATCH CHORUS

These parameters control the Chorus effect of the Patch.

Rate (Chorus Rate)

Adjust the speed of modulation for the Chorus effect.

Depth (Chorus Depth)

Adjust the depth of modulation for the Chorus effect.

Delay (Chorus Pre Delay)

Adjust the time delay after the original sound begins until the Chorus effect begins to apply. Higher settings result in a more spacious effect.

Fbk (Chorus Feedback Level)

Adjust the amount of sound from the Chorus output that is returned (fed back) to the Chorus. Higher settings result in a more intense effect.

Level (Chorus Level)

Adjust the volume of the Chorus effect.

Out (Chorus Output Assign)

Select the way in which the Chorus and Reverb are connected.

MIX: The Chorus sound and the Reverb sound are mixed.

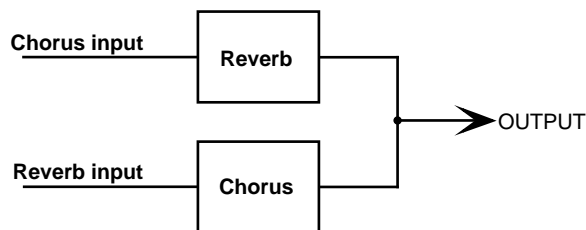

REV: Apply reverb to the chorus sound.

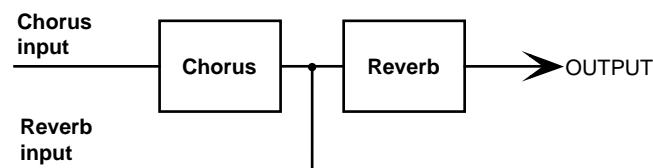

M+R: Mix the chorus sound to which reverb is not applied and the chorus sound to which reverb is applied.

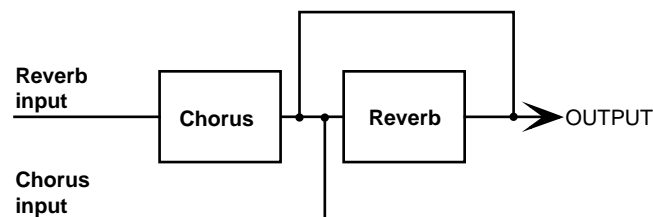

PATCH REVERB

These parameters control the Reverb effect of the Patch.

Type (Reverb/Delay Type)

Select the type of Reverb effect.

- ROOM1:** dense reverb with short decay
- ROOM2:** sparse reverb with short decay
- STAGE1:** reverb with greater late reverberation
- STAGE2:** reverb with strong early reflections
- HALL1:** reverb with clear reverberance
- HALL2:** reverb with rich reverberance
- DELAY:** a conventional delay
- PAN-DLY:** a delay with echoes that move left and right

Time (Reverb/Delay Time)

Adjust the time of reverberation. If you have selected DELAY or PAN-DLY, this parameter will adjust the time delay from the original sound until the first echo will sound.

Fbk (Delay Feedback Level)

Adjust the amount of delayed sound that is returned (fed back) to the delay. Higher values result in more delay repeats.

* If you have selected any one of the Reverb types (ROOM1–HALL2), this parameter has no effect.

HF Damp (Reverb/Delay HF Damp)

Adjust the frequency above which the reverberant sound will be cut. As the frequency is set lower, more of the high frequencies will be cut, resulting in a softer and more muted reverberance. If you do not want the high frequencies to be cut, set this parameter to BYPASS.

Level (Reverb/Delay Level)

Adjust the volume of the reverberant (or delayed) sound.

Using Controllers to Change How Sounds Are Played (CONTROL)

The parameters in this group determine how the controllers will function.

KEY MODE & BENDER (Key Assign Mode & Bender)

Assign (Key Assign Mode)

Specify how notes will be played. When playing a solo instrument Patch (such as sax or flute) it is effective to use a setting of SOLO.

POLY: Two or more notes can be played simultaneously.

SOLO: Only one note will sound at a time.

Legato (Solo Legato Switch)

Turn this parameter ON when you use Solo Legato, and OFF when you do not. Solo Legato is a function that works only when the Key Assign Mode is SOLO. When Solo Legato is ON, pressing a key while a previous key is already pressed will cause the note to change pitch to the pitch of the newly pressed key while continuing to sound. This is effective when you wish to simulate performance techniques such as a guitarist's hammering on and pulling off.

Bend Range

Specify the amount of pitch change that will occur when you move the Pitch Bend Lever. The left value specifies the pitch change that will occur when the lever is moved fully left. The right value specifies the pitch change that will occur when the lever is moved fully right. The left value has a range of -48-0 (-4-0 octaves), and the right value has a range of 0-+12 (0-1 octaves).

PORTAMENTO

Portamento is a function that causes the pitch to change smoothly from one note to the next played note. When the Key Assign Mode is SOLO, this is effective when simulating performance techniques such as a violinist's glissando.

Sw (Portamento Switch)

Set this to ON when you wish to use Portamento.

Time (Portamento Time)

Adjust the time over which the pitch will change to the new pitch.

Mode (Portamento Mode)

Select the way in which Portamento will be applied.

NORMAL: Portamento will always be applied.

LEGATO: Portamento will be applied only for notes played legato (i.e., when you press the next key before releasing the previous key).

Type (Portamento Type)

Select the way in which the pitch difference between the two notes will be related to the time of movement.

RATE: Time of movement will change in relation to the pitch difference.

TIME: Time of movement will be constant, regardless of the pitch difference.

Start (Portamento Start Pitch)

Portamento will begin anew if you press another key during a pitch movement. This setting specifies how the new portamento will start.

PITCH: Pitch will begin changing when the new key is pressed.

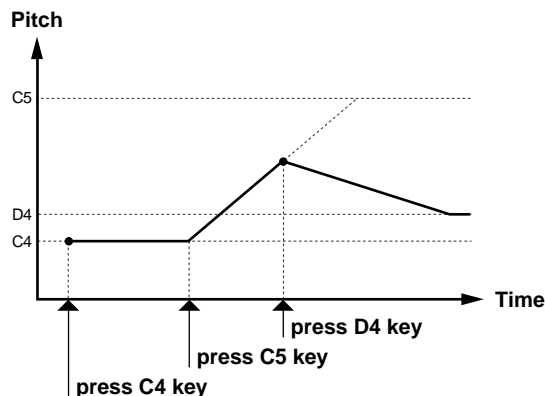

NOTE: Pitch will begin changing from the destination of the current movement.

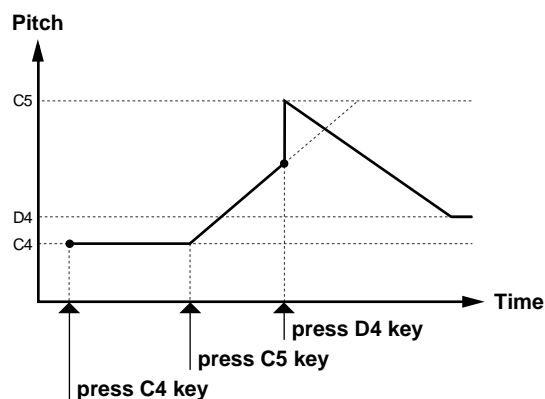

RxSWITCH (Receive Switch)

These parameters determine how Volume/Pan/Pitch Bend MIDI messages will be received by each Tone.

* In general, Volume messages control the volume, Pan messages control the stereo location, and Pitch Bend messages control the pitch of. However the XP-30 allows you to use these MIDI messages to control other parameters that you specify. Thus, if you are using a message to control another (i.e., a non-standard) parameter, you should turn off reception for that MIDI message. If reception is turned on, that MIDI message will control its standard function in addition to the special assignment you have made.

Volume (Receive Volume Switch)

If you want Volume messages to be received, turn this parameter ON. If not, turn it OFF.

Pan (Receive Pan Control Switch)

Specify how Pan messages will be received.

OFF: Not received.

CONT: Whenever a Pan message is received, it will immediately change the stereo location of the sound.

KEY-ON: The stereo location of the sound will be changed when the next note is played. If a Pan message is received while a note is sounding, the current stereo location will not change until the next note. In this case, the stereo location will change only for the note played later, and the currently sounding note will not move.

Pitch Bend (Receive Pitch Bend Switch)

If you want Pitch Bend messages to be received, turn this parameter ON. If not, turn it OFF.

DAMPER

Specify how Hold 1 (sustain pedal) messages will be received by each Tone.

Hold-1 RxSwitch (Receive Hold 1 Switch)

If you want Hold 1 messages to be received, turn this parameter ON. If not, turn it OFF.

Redamper (Redamper Switch)

If a Hold 1 message is received during the time between a note-off (when you release the key) until when the sound disappears, the currently sounding sounds will be sustained if this Redamper setting is ON. If you use this function, you must also turn on the Receive Hold 1 switch.

PEAK & HOLD

Hold messages (Hold 1, Hold 2, Sostenuto, Soft) are used to sustain the sound. The XP-30 allows you to use these Hold messages to hold the values of specific parameters.

- * If you use this function, you must also turn on the Receive Hold 1 switch for the Patch (previous screen).
- * If you select HOLD for the following parameters, you must also set the Hold parameter (SYSTEM/CONTROL/CONTROL SOURCE) to the type of Hold message being controlled.
- * If you select PEAK for the following parameters, you must also set the Peak parameter (SYSTEM/CONTROL/CONTROL SOURCE) to the type of Hold message being controlled.

EfxCtrl (EFX Control Peak/Hold)

Specify how Hold messages will affect the parameters you specify in the PATCH EFX CTRL display (PATCH/EFFECTS).

- OFF:** Parameter values will not be held even if Hold messages are received.
- HOLD:** Parameter values will be held when Hold messages are received.
- PEAK:** Parameter values will be held when Hold messages are received. However if a parameter value higher than the current one is received while Hold is still on, that new value will be held.

Ctrl 1 (Control 1 Peak/Hold)

Specify how Hold messages will affect the parameters controlled by Control Source 1 (Modulation: MIDI controller number 1). The settings are the same as for EFX Control.

Ctrl 2 (Control 2 Peak/Hold)

This parameter specifies the way in which Hold messages will control the parameter selected as Control Source 2 in the following display. The range of values is the same as for EFX control.

Ctrl 3 (Control 3 Peak/Hold)

This parameter specifies the way in which Hold messages will control the parameter selected as Control Source 3 in the following display. The range of values is the same as for EFX control.

CONTROL SOURCE

If you wish to use controllers to control a specific Tone parameter, select the controller in this display. Each Patch can have up to 3 control source assigned to it, but the function of control source 1 is fixed at Modulation (MIDI controller number 1).

Control 2 (Control Source 2)

Assign one of the following controllers to Control Source 2. If you want to use a controller that will be common to all Patches, or to use a controller that is not available for selection here, first select SYS-CTRL 1 or SYS-CTRL 2 then set the Control 1/2 parameter (SYSTEM/CONTROL/SYS-CTRL ASSIGN) to select the controller.

- OFF:** a controller will not be used
- SYS-CTRL1:** System controller (Control 1)
- SYS-CTRL2:** System controller (Control 2)
- MODULATION:** Modulation (MIDI controller number 1)
- BREATH:** Breath (MIDI controller number 2)
- FOOT:** Foot (MIDI controller number 4)
- VOLUME:** Volume (MIDI controller number 7)
- PAN:** Pan (MIDI controller number 10)
- EXPRESSION:** Expression (MIDI controller number 11)
- BENDER:** Pitch bend

AFTERTOUCH: Aftertouch

LFO1: LFO1 rate

LFO2: LFO2 rate

VELOCITY: Velocity

KEYFOLLOW: Key follow (adjust the parameter value depending on the keyboard location, relative to a standard value (0) at the C4 key)

PLAYMATE: Playmate (adjust the parameter value depending on the time length that the key is pressed)

Control 3 (Control Source 3)

Assign a controller to Control Source 3. The controllers available for selection are the same as for Control Source 2.

CONTROL 1-3

Specify the parameters to be controlled by Control Sources 1-3 and the depth of each parameter. The upper line of the display will show the Control Source selected in the previous display.

* From the PATCH PLAY display you can switch directly to the CONTROL1 display by pressing [CONTROLLER] while holding down [SHIFT].

Destination 1-4

Select the parameters to be controlled. Up to four parameters can be specified for each controller, and controlled simultaneously.

OFF: no control

PCH: WG Pitch

CUT: TVF Cutoff Frequency

RES: TVF Resonance

LEV: TVA Level

PAN: TVA Pan

MIX: Output level of Tone

CHO: Chorus Send level of Tone

REV: Reverb Send level of Tone

PL1: LFO1 depth of WG Pitch

PL2: LFO2 depth of WG Pitch

FL1: LFO1 depth of TVF Cutoff Frequency

FL2: LFO2 depth of TVF Cutoff Frequency

AL1: LFO1 depth of TVA Level

AL2: LFO2 depth of TVA Level

pL1: LFO1 depth of TVA Pan

pL2: LFO2 depth of TVA Pan

L1R: LFO1 rate

L2R: LFO2 rate

Depth 1-4

Adjust the amount of change that will occur in response to controller movement. Higher value will cause greater change. Negative (-) values will reverse the direction of the change. For LFO rates, negative (-) values will lengthen the period (causing slower modulation), and positive (+) values will shorten the period (causing faster modulation).

■ Modifying Waveform (WAVE)

This group contains parameters related to the basic waveform (Wave) of the Tone.

WAVE

Group (Wave Group)

Select the Group of the Wave.

INT-A, B: Internal A, B

EXP-A-E: Wave Expansion Boards A-E

* *It is not possible to select a Group of a Wave Expansion Board that is not installed.*

Number (Wave Number)

Select the Wave number. The name of the Wave will be displayed in parentheses ().

Gain (Wave Gain)

Adjust the gain (volume boost) of the Wave. The setting range is -6+12 dB, in steps of 6 dB. An increase of 6 dB doubles the gain. When using the Booster to distort the sound, it is effective to use the maximum Gain setting.

Switch (Tone Switch)

When you wish to use the Tone, set this ON. When not using the Tone, set this OFF. In order to make best use of the available number of simultaneous voices, unused Tones should be turned off.

* *When you use TONE SWITCH [1]-[4] to turn Tones on/off, this is the parameter that is being set.*

FXM (Frequency cross modulation)

FXM is a function that uses frequency modulation to add new harmonic components to the sound. It can be used as a simple ring modulator in order to add a metallic flavor.

Switch (FXM Switch)

When you wish to use FXM turn this ON. If not, turn it OFF.

Color (FXM Color)

Select one of four ways in which FXM will use frequency modulation.

Depth (FXM Depth)

Adjust the depth of the frequency modulation created by FXM.

TONE DELAY

This parameter produces a time delay from the moment the key is pressed (or released) until when the Tone begins to sound. Since you can adjust the timing of each Tone, you can create effects in which pressing a single key produces two or more sounds at different times.

* *If you do not wish to use Tone Delay, set Mode to NORMAL and Delay Time to 0.*

Mode (Tone Delay Mode)

Select the way in which the Tone will sound.

NORMAL: The Tone will sound after the specified Delay Time.

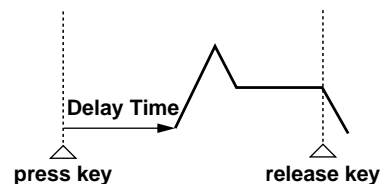

HOLD: If the key is pressed for longer than the specified Delay Time, the Tone will sound after the Delay Time. If the key is released earlier than the Delay Time, the Tone will not sound.

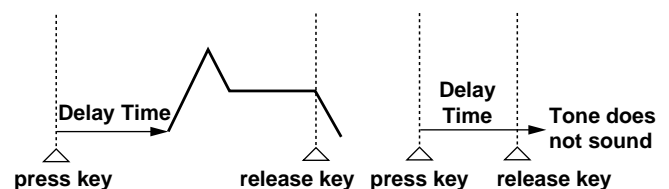

PLAYMATE: If 2 seconds or more pass before the next key is pressed, the Tone will sound after the Delay Time. If less than 2 seconds pass before the next key is pressed, that interval will become the Delay Time after which the Tone will sound.

CLOCK-SYNC: Synchronize the Delay Time to either the Patch Tempo (PATCH/COMMON/PATCH CLOCK), the Performance Tempo (PERFORM/COMMON/PERFORM CLOCK), or the tempo clock of the XP-30's system. If you want to use a fixed tempo in Patch mode (Tempo parameter setting), set the Source parameter (PATCH/COMMON/PATCH CLOCK) to PATCH and set the desired tempo.

If you want to use the system's tempo clock in Patch mode, set the Source parameter (PATCH/COMMON/PATCH CLOCK) to SYSTEM.

If you want to use a fixed tempo in Performance mode (Tempo parameter setting), set the Source parameter (PERFORM/COMMON/PERFORM CLOCK) to PERFORM and set the desired tempo.

If you want to use the system's tempo clock in Performance mode, set the Source parameter (PERFORM/COMMON/PERFORM CLOCK) to SYSTEM.

KEY-OFF-N: The Tone will not sound while the key is being pressed, but will sound after the Delay Time when the key is released.

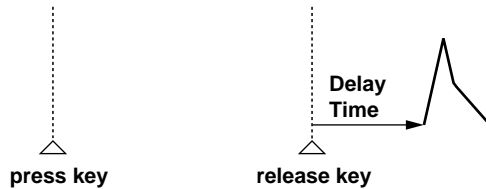

KEY-OFF-D: The Tone will not sound while the key is being pressed, but will sound after the Delay Time when the key is released. However for this setting, the TVA envelope of the Tone will begin when the key is pressed, so in most cases only the decay portion of the sound will be heard.



* If you have selected a Wave that is a decay-type sound (i.e., a sound that fades away naturally even if the key is not released), selecting KEY-OFF-N or KEY-OFF-D may result in no sound being heard.

TEMPO-SYNC: If you select a Wave with tempo (BPM) being displayed, the Tone will synchronize to the tempo clock of the system regardless of which key is pressed. This is most effective when playing phrase loops in sync with the tempo of a song (p. 130).

If you want to sync to the tempo of a system in Patch mode, set the Source parameter (PATCH/COMMON/PATCH CLOCK) to SYSTEM.

If you want to sync to the tempo of a system in Performance mode, set the Source parameter (PERFORM/COMMON/PERFORM CLOCK) to SYSTEM.

* When TEMPO-SYNC is selected, pitch and FXM settings will be ignored.

* When selecting TEMPO-SYNC, also set the Time parameter to 0. If other values are set, Tone Delay will be activated.

Time (Tone Delay Time)

Specify the time after when the Tone will sound when using Tone Delay.

If PLAYMATE has been selected in Tone Delay mode, a setting of 64 will mean that the delay time will be set to the interval between the previous Note On and the current Note On. A setting of 127 will result in a time that is twice as long as for a setting of 64, and a setting of 32 will result in a time that is 1/2 as long.

If the Tone Delay Mode is set to CLOCK-SYNC, the setting will be in quarter-note steps, and the corresponding note value symbol will also be displayed. This lets you specify the delay time in note lengths relative to the synchronization tempo.

* If the Type parameter (PATCH/COMMON/STRUCT) is set to a selection of 2–10, the outputs of Tone 1 (3) and 2 (4) will be combined into Tone 2 (4). This means that the settings of Tone 1 (3) will be ignored.

■ Modulating Sounds (LFO)

The LFO (Low Frequency Oscillator) creates cyclic change. Each Tone has two LFOs, and these can be used to apply change to the WG Pitch/TVF Cutoff Frequency/TVA Level/TVA Pan.

How to Use the LFO

Applying LFO to the Pitch creates vibrato, applying it to TVF Cutoff Frequency creates wah, and applying it to TVA Level creates tremolo. When LFO is applied to the TVA Pan, the stereo location of the sound will change cyclically. Depending on the settings, LFO can be used to cyclically exchange two Tones. For example if you wish to shift back and forth between Tones 1 and 2, select the same LFO settings for both, but make LFO Depth settings of opposite polarity (+/-) for their TVA Level settings.

LFO1/LFO2

Since both LFOs have the same parameters, there are explained here together.

Form (LFO Form)

Select the waveform of the LFO.

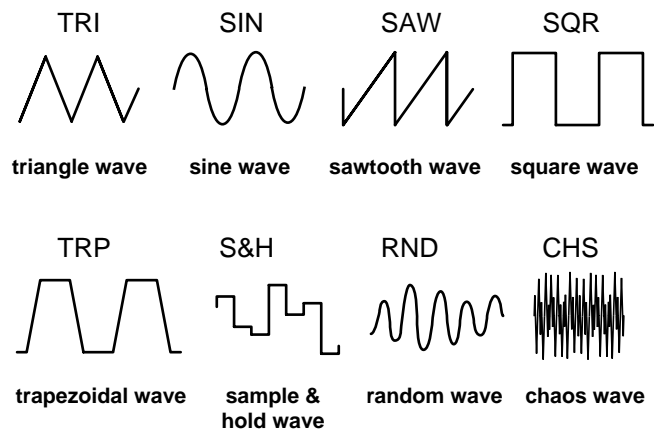

Key Sync (LFO Key Sync)

Specifies whether you want the LFO cycle to start in sync with the timing of a key press (ON) or not (OFF).

Rate (LFO Rate)

Adjust the modulation rate of the LFO.

* If you have set the External Sync value to CLOCK, this parameter will indicate a note value in multiples of a quarter note, and the corresponding note value symbol will also be displayed. This allows you to set the LFO rate in terms of a note length in the synchronization tempo.

* The Chaos waveform has no wavelength. When the Chaos waveform is selected, the Rate setting has no effect.

ExtSync (LFO External Sync)

Select how the LFO will be synchronized.

OFF: Unsynchronized

CLOCK: Synchronize the LFO to the Patch Tempo, Performance Tempo, or the tempo clock of the XP-30's system.

If you want to use a fixed tempo in Patch mode (Tempo parameter setting), set the Source parameter (PATCH/COMMON/PATCH CLOCK) to PATCH and set the desired tempo.

If you want to use the system's tempo clock in Patch mode, set the Source parameter (PATCH/COMMON/PATCH CLOCK) to SYSTEM.

If you want to use a fixed tempo in Performance mode (Tempo parameter setting), set the Source parameter (PERFORM/COMMON/PERFORM CLOCK) to PERFORM and set the desired tempo.

If you want to use the system's tempo clock in Performance mode, set the Source parameter (PERFORM/COMMON/PERFORM CLOCK) to SYSTEM.

Mode (LFO Fade Mode)

Select how the LFO will be applied.

ON-IN: The LFO will fade in after the key is pressed.

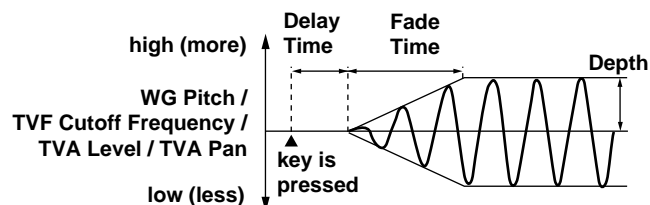

ON-OUT: The LFO will be immediately applied when the key is pressed, and will then fade out.

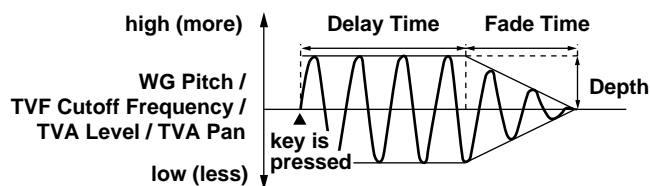

OFF-IN: The LFO will fade in after the key is released.

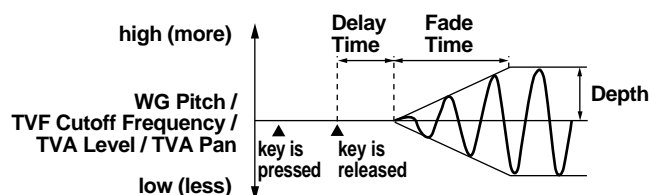

OFF-OUT:The LFO will be immediately applied when the key is pressed, and will begin fading out when the key is released.

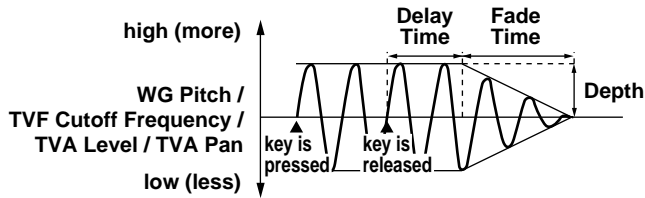

Delay (LFO Delay Time)

Adjust the time from when the key is pressed (or released) until the LFO begins to take effect. (Refer to the diagrams for Fade Mode.)

Fade (LFO Fade Time)

Adjust the time over which the LFO rises to its full effect (or diminishes). (Refer to the diagrams for Fade Mode.)

Offset (LFO Offset)

Adjust the basic value of the LFO waveform upward or downward.

LFO DEPTH 1:2

These parameters adjust the way in which the LFO affects each parameter. Two values are displayed for each parameter. The left one is for LFO1, and the right one is for LFO2.

Pitch (Pitch LFO Depth 1, 2)

Adjust how much the LFO will affect the WG Pitch.

TVF (TVF LFO Depth 1, 2)

Adjust how much the LFO will affect the TVF Cutoff Frequency.

TVA (TVA LFO Depth 1, 2)

Adjust how much the LFO will affect the TVA Level.

Pan (Pan LFO Depth 1, 2)

Adjust how much the LFO will affect the TVA Pan.

Modifying Pitch (PITCH)

The parameters in this group affect the WG Pitch of each Tone.

PITCH

Specify the basic pitch of each Tone.

Coarse (Coarse Tune)

Adjust the pitch in semitone steps (-4+4 octaves).

Fine (Fine Tune)

Adjust the pitch in 1-cent steps (-50+50 cents).

* One cent is 1/100th of a semitone.

Random (Random Pitch Depth)

If you want the pitch of the Tone to change randomly each time the key is pressed, set the desired amount of pitch change here. If you do not want the pitch to change randomly, set this to 0. The value is in units of 1 cent.

Keyfollow (Pitch Key Follow)

This parameter sets the amount of pitch change that will occur when you move one octave on the keyboard. If you want the pitch to change 1 octave when the keyboard position rises 1 octave (as on normal keyboard instruments), set this parameter to +100. If you want the pitch to rise 2 octaves when the keyboard position rises 1 octave, set this parameter to +200. Negative (-) settings will make the pitch become lower as you play up the keyboard. If you want all keys of the keyboard to produce the same pitch, set this parameter to 0.

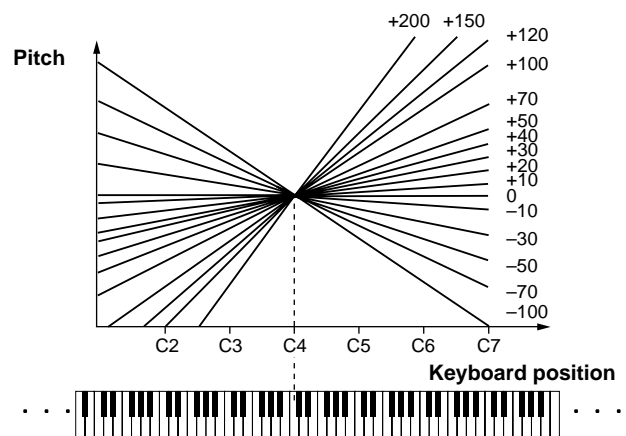

PCH ENVELOPE (Pitch Envelope)

These parameters determine how the Pitch Envelope affects the pitch.

Envelope Depth (Pitch Envelope Depth)

Adjust the amount of the Pitch Envelope. Higher settings will result in greater change. Negative (-) settings will invert the direction of the envelope.

Velocity Sens (Pitch Envelope Velocity Sensitivity)

Set this parameter when you want your keyboard playing dynamics to affect the amount of pitch change. For higher settings, there will be a greater difference between softly and strongly played notes. Negative (-) settings will invert the direction of change.

PCH TIME ENV (Pitch Time Envelope)

These parameters determine how keyboard playing dynamics will affect the times of the Pitch Envelope.

V-T1 (Pitch Envelope Time 1 Velocity Sensitivity)

Use this parameter when you want keyboard playing dynamics (velocity) to affect T1 (time) of the Pitch Envelope. For higher settings, there will be a greater difference between softly and strongly played notes. For positive (+) settings, keyboard velocity will speed up the T1 time. For negative (-) settings, keyboard velocity will slow down the T1 time.

V-T4 (Pitch Envelope Time 4 Velocity Sensitivity)

Use this parameter when you want keyboard playing dynamics (velocity) to affect T4 (time) of the Pitch Envelope. For higher settings, there will be a greater difference between softly and strongly played notes. For positive (+) settings, keyboard velocity will speed up the T4 time. For negative (-) settings, keyboard velocity will slow down the T4 time.

Time Keyfollow (Pitch Envelope Time Key Follow)

Use this parameter when you want the keyboard location of the note to affect the times (T2–T4) of the Pitch Envelope. Higher settings of this parameter will cause greater time change relative to the envelope time at middle C (C4). Positive (+) settings will cause the time change to become shorter for notes to the right of middle C. Negative (-) settings will cause the time change to become longer for notes to the right of middle C.

PCH ENVELOPE (Pitch Envelope)

These parameters set the Pitch Envelope (the shape of the pitch change over time).

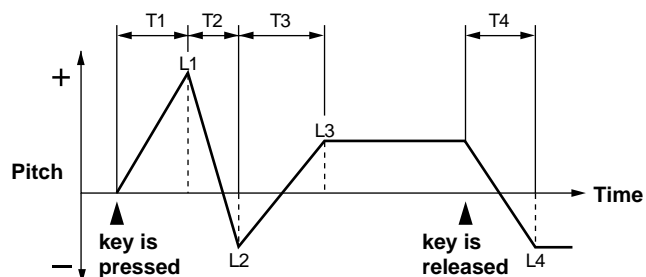

T1–4 (Pitch Envelope Time 1–4)

Set the times over which the pitch will change from one point to the next.

L1–L4 (Pitch Envelope Level 1–4)

Set the amount of pitch change (relative to the basic pitch) for each point.

Modifying the Brightness of Sound with a Filter (TVF)

The parameters in this group allow you to use the TVF (Time Variant Filter) to modify the frequency characteristics of the sound.

FILTER

These parameters are the TVF filter settings.

Type (Filter Type)

Select the filter type.

- OFF:** filter not used.
- LPF (Low Pass Filter):** Cut the frequencies above the Cutoff Frequency. This is the most common type of filter used in synthesizers.
- BPF (Band Pass Filter):** Pass only the frequencies in the area of the Cutoff Frequency.
- HPF (High Pass Filter):** Cut the frequencies below the Cutoff Frequency.
- PKG (Peaking Filter):** Emphasize the frequencies in the area of the Cutoff Frequency.

Cut (Cutoff Frequency)

Set the frequency of the filter.

Res (Resonance)

Emphasize the frequencies in the area of the Cutoff Frequency. For some settings, excessive levels can cause oscillation and distortion.

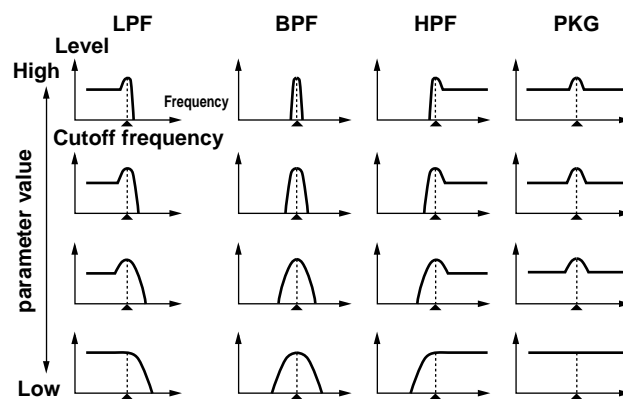

Keyfollow (Cutoff Frequency Key Follow)

Use this parameter when you want the Cutoff Frequency to be affected by the keyboard position.

Higher values will result in greater change relative to middle C (C4). Positive (+) settings will make the Cutoff Frequency rise as you play further the right of the keyboard. Negative (-) settings will make the Cutoff Frequency fall.

EnvDepth (TVF Envelope Depth)

Adjust the depth of the TVF envelope. Higher settings will result in greater change. Negative (-) values will invert the envelope.

TVF VELOCITY

These parameters determine how keyboard velocity will affect TVF Envelope/Cutoff Frequency/Resonance.

V-Sens (TVF Envelope Velocity Sensitivity)

Use this parameter when you want velocity to affect the TVF Envelope. Higher settings will result in a greater difference between strongly and softly played notes. Negative (-) settings will invert the effect.

V-Curve (TVF Envelope Velocity Curve)

Select one of 7 types of curve with which velocity will affect the Cutoff Frequency. The curve is displayed graphically at the right of the value.

V-Resonance (Resonance Velocity Sensitivity)

Use this parameter when you want velocity to affect the Resonance. Higher settings will result in a greater difference between strongly and softly played notes. Negative (-) settings will invert the effect.

TVF TIME ENV (TVF Time Envelope)

These parameters determine how keyboard velocity will affect the times of the TVF envelope.

V-T1 (TVF Envelope Time 1 Velocity Sensitivity)

Use this parameter when you want velocity to affect T1 (time) of the TVF envelope. Higher settings will result in a greater difference between strongly and softly played notes. If you want higher keyboard velocities to speed up the T1 time, use positive (+) settings. To slow down the T1 time, use negative (-) settings.

V-T4 (TVF Envelope Time 4 Velocity Sensitivity)

Use this parameter when you want Key Off Velocity (the speed at which you release a key) to affect T4 (time) of the TVF envelope. Higher settings will result in a greater difference between quickly and slowly released notes. If you want a quicker release to speed up the T4 time, use positive (+) settings. To slow down the T4 time, use negative (-) settings.

Time Keyfollow (TVF Envelope Time Key Follow)

Use this parameter when you want keyboard position to affect the times (T2-T4) of the TVF envelope. Higher settings will result in greater changes relative to middle C (C4). Positive (+) settings will result in shorter times as you play toward the right of the keyboard. Negative (-) settings will conversely result in longer times.

TVF ENVELOPE

These parameters set the TVF envelope (the way in which the cutoff frequency will change over time).

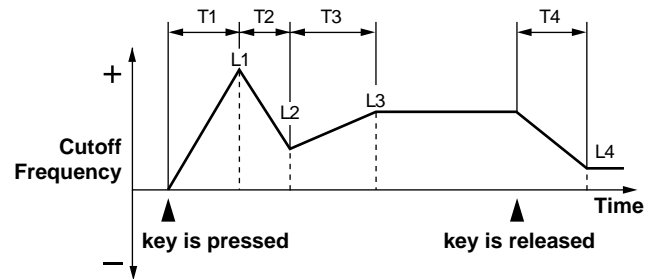

T1-T4 (TVF Envelope Time 1-4)

Set the times over which the cutoff frequency will move from one point to the next.

L1-L4 (TVF Envelope Level 1-4)

Set the cutoff frequency levels for each point, relative to the basic cutoff frequency.

■ Changing the Sound's Volume and Stereo Location (TVA)

The TVA (Time Variant Amplifier) controls volume changes and stereo location.

TVA

Level

Adjust the basic volume of the Tone. Use this parameter to adjust the volume balance between Tones.

Pan

Adjust the pan (stereo location) of the Tone. L64 is full left, 0 is center, and 63R is full right.

V-Sens (TVA Envelope Velocity Sensitivity)

Use this parameter when you want keyboard velocity to affect the amount of change produced by the TVA envelope. Higher settings will result in a greater difference between strongly and softly played notes. Negative (-) settings will invert the effect.

V-Curve (TVA Envelope Velocity Curve)

Select one of 7 curves that will determine how keyboard playing dynamics will affect the TVA envelope. The selected curve will be displayed at the right of the numerical value.

Chapter 3. Creating Your Own Sounds

BIAS

Use the Bias parameter when you want keyboard position to affect the TVA level.

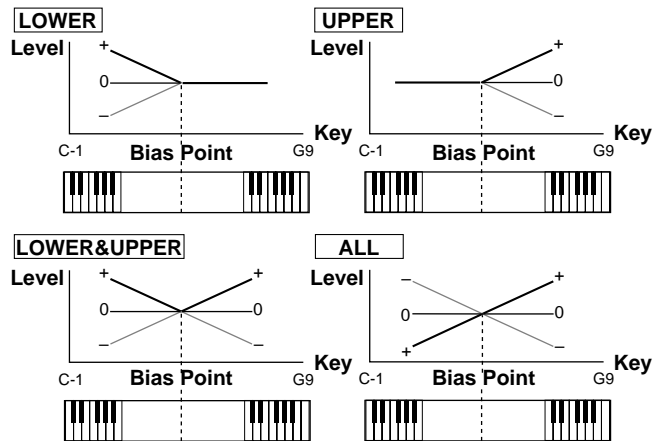

Bias (Bias Level)

Adjust the angle of the volume change that will occur in the selected Bias Direction. Higher settings will result in greater change. Negative (-) values will invert the change.

Point (Bias Point)

Select the key at which the volume will begin to change.

Direction (Bias Direction)

Select the direction in which change will occur starting from the Bias Point.

- LOWER:** the range below the Bias Point
- UPPER:** the range above the Bias Point
- LOWER&UPPER:** the ranges both above and below the Bias Point
- ALL:** the entire keyboard will be biased at the angle determined by the Bias Level, relative to the Bias Point

PAN MODULATE

Use these parameters to affect the location of the TVA Pan.

Keyfollow (Pan Key Follow)

Use this parameter when you want the keyboard position to change the stereo location. Higher values will result in greater change relative to middle C (C4). Positive (+) settings will cause notes played toward the right of the keyboard to be panned right. Negative (-) settings will cause the opposite.

Random (Random Pan Depth)

Use this parameter when you want the stereo location to change randomly each time you press a key. Higher values will result in a greater width of change.

Alternate (Alternate Pan Depth)

Use this parameter when you want the stereo location to alternate between left and right each time you press a key. Higher values will result in a greater width of change.

L or R values can be set, and this will reverse the left/right order of the panning. If you want to alternate the pan position of two Tones, set them to opposite L and R settings.

TVA TIME ENV (TVA Time Envelope)

These parameters determine how the keyboard will affect the time changes of the TVA envelope.

V-T1 (TVF Envelope Time 1 Velocity Sensitivity)

Use this parameter when you want velocity to affect T1 (time) of the TVA envelope. Higher settings will result in a greater difference between strongly and softly played notes. If you want higher velocities to speed up T1 time, use positive (+) values. If you want higher velocities to slow down T1 time, use negative (-) values.

V-T4 (TVA Envelope Time 4 Velocity Sensitivity)

Use this parameter when you want Key Off Velocity (the speed at which you release a key) to affect T4 (time) of the TVA envelope. Higher settings will result in a greater difference between quickly and slowly released notes. If you want a quicker release to speed up the T4 time, use positive (+) settings. If you want a quicker release to slow down the T4 time, use negative (-) settings.

Time Keyfollow (TVA Envelope Time Key Follow)

Use this parameter when you want keyboard position to affect TVA envelope times (T2–T4). Higher values will result in a greater change relative to middle C (C4). Positive (+) settings will result in shorter times as you play toward the right of the keyboard. Negative (-) settings will result in longer times as you play toward the right of the keyboard.

TVA ENVELOPE (TVA Envelope)

These parameters make settings for the TVA envelope (changes over time in the TVA level).

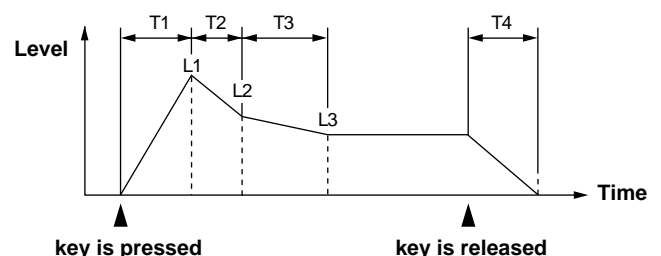

T1–T4 (TVA Envelope 1–4)

Adjust the time over which the volume changes from one point to the next.

L1–L3 (TVA Envelope 1–3)

Adjust the volume level of each point relative to the basic TVA level.

Functions of Performance Parameters

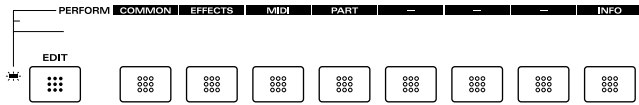

■ Settings Common to the Entire Performance (COMMON)

This display is used when setting parameters that are not part of other groups. These include Performance Name and Key Mode.

PERFORM NAME (Performance Name)

You can assign a name to the Performance of up to 12 characters.

* For details on assigning names, refer to “**Assigning a Name**” (p. 46).

PERFORM CLOCK

Some parameters allow you to set a time value in terms of a note length which is determined by a specified tempo; Rate parameters (PATCH/LFO/LFO1, 2), Time parameter (PATCH/WAVE/TONE DELAY), and some Multi-Effects parameters. The specified tempo used by these parameters can be set for each Patch. However when a Patch is used in Performance mode, the Patch settings will be ignored, and the settings of this display will be used instead.

Source (Performance Clock Source)

Select the source of the Performance Clock.

PERFORM: Synchronize to the Performance Tempo setting.

SYSTEM: Synchronize to the tempo clock of the system.

* The Performance Clock does not transmit clock messages from MIDI OUT connector.

Tempo (Performance Tempo)

Set the Performance Tempo setting.

* When Source (Performance Clock Source) is set to SYSTEM, synchronization will be according to the tempo clock of the system, so it will not be possible to set the tempo value. The tempo of the system will be displayed in parentheses ().

PERFORM COMMON

Key Mode

This parameter determines how the sound source will be played from the XP-30's keyboard.

LAYER: When you play the keyboard, all Parts whose Local parameter (PERFORM/MIDI/MIDI) is turned on will sound. Transmission of MIDI messages from the controller section to external MIDI devices will be determined by the Tx parameter setting (PERFORM/MIDI/MIDI) of each Part.

SINGLE: When you play the keyboard, only the specified Part (the Part shown in the display) will sound. MIDI messages will be transmitted from the controller section to the external MIDI devices even if the Local parameter and Tx parameter settings for each Part (PERFORM/MIDI/MIDI) are turned off.

* If you have selected a Layer-type Performance, the upper right of the PERFORM PLAY display will indicate “LAYER p*” (* is the part number). If you have selected a Single-type Performance, the number of the Part that can be played from the keyboard will be displayed.

* If LAYER has been selected and you try to play Patches of all Parts, you probably won't be able to play many simultaneous voices. When layering Patches, be aware of the number of voices available and turn off unnecessary Parts. Making Key Range settings for each Part allows you to split the keyboard to play different Parts in separate sections.

* To switch between SINGLE and LAYER from the PERFORM PLAY display, hold down [SHIFT] while you press [SOLO].

Key Range (Key Range Switch)

This parameter determines whether or not the Key Range settings (next display) will be applied or not. If you want them to be applied, turn this ON.

KEY RANG (Key Range)

Set the range in which each Part will sound. Use this when you wish to play different Patches in different areas of the keyboard.

Lower (Key Range Lower)

Set the lowest note that the Part will play.

Upper (Key Range Upper)

Set the highest note that the Part will play.

* If Key Range settings have been made for the Patch, only the notes for which the Key Range settings of the Patch and Performance overlap will play.

* It is not possible to set Lower to a value greater than Upper, nor Upper to a value less than Lower. If you attempt to do so, both values will change together.

* If you have used Octave Shift (System) or the Transpose parameter (SYSTEM/CONTROL/KEYBOARD) to transpose the pitch of the XP-30's keyboard, the keyboard area specified by Key Range will also be shifted.

KEYBOARD

Octave Shift

This parameter adjusts the pitch of each Part in units of an octave (-3--+3 octaves).

■ Setting Effects for a Performance (EFFECTS)

This group contains settings for the Multi-Effects/Chorus/Reverb effects used by a Performance.

OUTPUT

Specify how each Part will be output.

Output Assign (Output Assign/Output Level)

Select whether the output of each Part will be sent through Multi-Effects, and adjust the volume level of each Part.

- MIX:** output to the OUTPUT jack without passing through Multi-Effects.
- EFX:** output to the OUTPUT jack through Multi-Effects.
- PATCH:** use the Output Assign settings (for each Tone) of the Patch assigned to each Part.

* If you select MIX or EFX, the setting of the Output Assign parameter (PATCH/EFFECTS/OUTPUT) will be ignored.

Chorus (Chorus Send Level)

Adjust the amount of Chorus that is applied to each Part.

Reverb (Reverb Send Level)

Adjust the amount of Reverb that is applied to each Part.

PERFORM EFX TYPE (Performance EFX TYPE)

These parameters set the Performance Multi-Effects.

* If EFX Source has been set to use the EFX settings of the Patch assigned to one of the Parts, the Part number will be shown in the upper left of the display.



Type (EFX Type)

Select the type of Multi-Effects. For details refer to “Multi-Effects Types (EFX Parameter)” (p. 93).

* If you have selected the EFX parameter settings of one of the Patches assigned to a Part as the EFX Source, the EFX Type of that Patch will be displayed.

Source (EFX Source)

Select the EFX parameter settings that will be used by the Performance. If you wish to use the EFX parameter settings of the Performance, select PERFORM. If you wish to use the EFX parameter settings of the Patch assigned to one of the Parts, select the Part number. Since the Rhythm Set does not have EFX parameter settings, it is not possible to select Part 10.

When the EFX Parameter Settings of a Patch Are Selected

When the EFX parameter settings of a Patch are selected, those settings will be displayed in the EFX parameter setting display of the Performance, and you will be able to modify them. If you wish to keep the Patch EFX parameter settings that you modify, rewrite the Patch settings. The modified Patch EFX parameter settings will be lost if you select a different Patch.

PERFORM EFX PRM (Performance EFX Parameters)

The EFX parameters for the selected EFX Type will be displayed. For details refer to “Multi-Effects Types (EFX Parameter)” (p. 93).

* If EFX Source has been set to use the EFX parameter settings of the Patch assigned to one of the Parts, the Part number will be shown in the upper left of the display.

PERFORM EFX OUT (Performance EFX Output)

These parameters specify the output for the Part for which EFX was selected in Output Assign.

- * For Parts which have an Output Assign setting of MIX, the settings of this display will be ignored.
- * For Parts which have an Output Assign setting of PATCH, the Output Assign settings of each Tone of the Patch will be used. In other words, the settings of this display will apply only to Tones for which EFX is selected.

Mix Out (EFX Output Level)

Adjust the volume of the direct sound and Multi-Effects sound.

Chorus (Chorus Send Level)

Adjust the amount of Chorus applied to the sound that passes through Multi-Effects.

Reverb (Reverb Send Level)

Adjust the amount of Reverb applied to the sound that passes through Multi-Effects.

PERFORM EFX CTRL (Performance EFX Control)

Use this parameter when you wish to use a specific controller to control an EFX parameter. The types of EFX parameters available for control will depend on the EFX type. For details refer to “Multi-Effects Types (EFX Parameter)” (p. 93).

The upper line of the display will show the EFX parameter to be controlled. For each EFX parameter you can specify the EFX Control Source and the EFX Control Depth.

EFX Control Source 1, 2

The MIDI controllers that can be used are shown below. If you wish to use a controller that is common to all Patches, or a controller that cannot be selected here, first select SYS-CTRL1 or SYS-CTRL2, and then use the Control 1/2 parameter (SYSTEM/CONTROL/SYS-CTRL ASSIGN) to select the controller.

- OFF:** a controller will not be used
- SYS-CTRL1:** System controller (Control 1)
- SYS-CTRL2:** System controller (Control 2)
- MODULATION:** Modulation (MIDI controller number 1)
- BREATH:** Breath (MIDI controller number 2)
- FOOT:** Foot (MIDI controller number 4)
- VOLUME:** Volume (MIDI controller number 7)
- PAN:** Pan (MIDI controller number 10)
- EXPRESSION:** Expression (MIDI controller number 11)
- PITCH BEND:** Pitch bend
- AFTERTOUCHE:** Aftersustain

EFX Control Depth 1, 2

Adjust the amount of change that will occur in response to controller movement. Higher values will result in greater change. Negative (-) values will invert the direction of the change.

PERFORM CHORUS

Make settings for the Chorus effect of the Performance.

** In Performance mode, the Chorus settings of the Patches used by each Part will be ignored (except for the Send Level parameter).*

Rate (Chorus Rate)

Adjust the speed of modulation for the chorus.

Depth (Chorus Depth)

Adjust the depth of modulation for the chorus.

Delay (Chorus Pre Delay)

Adjust the time delay from when the direct sound begins until the chorus sound is heard. Higher values will create a more spacious sound.

Fbk (Chorus Feedback Level)

Adjust the amount of chorus sound that is returned (fed back) into the chorus. Higher values will create a more intense effect.

Level (Chorus Level)

Adjust the volume level of the chorus sound.

Out (Chorus Output Assign)

Select the way in which the Chorus and Reverb are connected.

MIX: The Chorus sound and the Reverb sound are mixed.

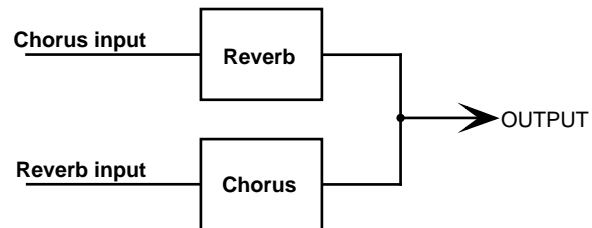

REV: Apply reverb to the chorus sound.

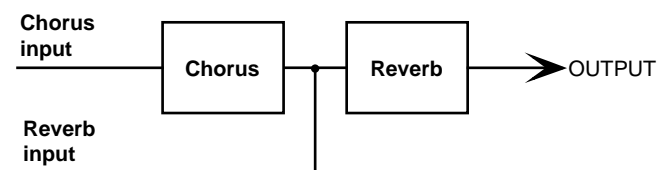

M+R: Mix the chorus sound to which reverb is not applied and the chorus sound to which reverb is applied.

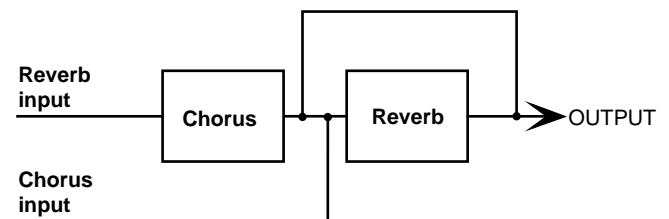

PERFORM REVERB

Make settings for the Reverb effect of the Performance.

** In Performance mode, the Reverb settings of the Patches used by each Part will be ignored (except for the Send Level parameter).*

Type (Reverb/Delay Type)

Select the type of Reverb effect.

- ROOM1:** dense reverb with short decay
- ROOM2:** sparse reverb with short decay
- STAGE1:** reverb with greater late reverberation
- STAGE2:** reverb with strong early reflections
- HALL1:** reverb with clear reverberance
- HALL2:** reverb with rich reverberance
- DELAY:** a conventional delay
- PAN-DLY:** a delay with echoes that move left and right

Time (Reverb/Delay Time)

Adjust the time of reverberation. If you have selected DELAY or PAN-DLY, this parameter will adjust the time delay from the original sound until the first echo will sound.

Fbk (Delay Feedback Level)

Adjust the amount of delayed sound that is returned (fed back) to the delay. Higher values result in more delay repeats.

* *If you have selected any one of the Reverb types (ROOM1–HALL2), this parameter has no effect.*

HF Damp (Reverb/Delay HF Damp)

Adjust the frequency above which the reverberant sound will be cut. As the frequency is set lower, more of the high frequencies will be cut, resulting in a softer and more muted reverberance. If you do not want the high frequencies to be cut, set this parameter to BYPASS.

Level (Reverb/Delay Level)

Adjust the volume of the reverberant (or delayed) sound.

■ Making MIDI Settings for a Part (MIDI)

MIDI

These parameters determine how each Part will transmit and receive MIDI messages.

Channel (MIDI Channel)

Set the MIDI channel of each Part.

* *If this is set to the same channel as the Control Channel parameter (SYSTEM/MIDI/PERFORM MIDI), attempting to use MIDI messages (Program Change and Bank Select) from an external device to select Patches will select Performances instead. If you want to select Patches, change the Control Channel to a different setting.*

Rx (Receive Switch)

Specify whether or not you want each Part to receive MIDI messages from the external MIDI devices.

Normally you will leave this ON, but you can turn it OFF when you do not want a specific Part to be playing during a song playback.

* *To switch between ON and OFF from the PERFORM PLAY display, hold down [SHIFT] while you press the function button for the Part you want to alter.*

Tx (Transmit Switch)

This determines, for each Part, whether or not data generated by the controller section is sent as MIDI messages from the MIDI OUT connector when the Key Mode parameter (PERFORM/COMMON/PERFORM COMMON) is set to LAYER.

Normally you will leave this ON, but you can turn it OFF when you do not want the XP-30 to control external sound sources.

* *When the Key Mode parameter (PERFORM/COMMON/PERFORM COMMON) is set to SINGLE, the setting for the Tx parameter is deactivated, and only the MIDI messages of the current Part are sent from the MIDI OUT connector.*

Local (Local Switch)

Specify for each Part whether or not you want to disconnect the controller section from the internal sound source when the Key Mode parameter (PERFORM/COMMON/PERFORM COMMON) is set to LAYER.

Normally you will leave this ON, but you can turn it OFF when you want to use the XP-30 only to control an external sound source.

* *To switch between ON and OFF from the PERFORM PLAY display, press the function button for the Part you want to alter.*

* *When the Key Mode parameter (PERFORM/COMMON/PERFORM COMMON) is at SINGLE, the setting for the Local parameter is deactivated, and when you finger the keyboard, only the patch for the current Part sounds.*

RxSWITCH (Receive Switch)

Specify whether each Part will receive certain MIDI messages or not.

Volume (Receive Volume Switch)

If you want the Part to receive Volume messages, turn this ON. If not, turn this OFF.

Hold-1 (Receive Hold 1 Switch)

If you want the Part to receive Hold 1 messages, turn this ON. If not, turn this OFF.

Program Change (Receive Program Change Switch)

If you want the Part to receive Program Change messages, turn this ON. If not, turn this OFF.

* *If you want a Part to receive Program Change messages, you must also turn the Program Change parameter ON (SYSTEM/MIDI/RECEIVE MIDI).*

TRANSMIT (Transmit Bank Select)

BankSelectGroup (Transmit Bank Select Group)

When you select a Performance, Bank Select and Program Change messages will be transmitted for the Patch or Rhythm Set assigned to each Part as determined by this setting.

PATCH: When you select a Performance, Bank Select messages and Program Change messages for the Patch/Rhythm Set that is assigned to each Part will not be transmitted.

BS1-7: When you select a Performance, Bank Select and Program Change messages will be transmitted for the Patch/Rhythm Set that is assigned to each Part. In this case, the Bank Select Number that is transmitted will be determined by the Bank Select Group (BS1–7) setting. In the BANK SEL GROUP display (SYSTEM/MIDI) you can set the Bank Select number for each Bank Select Group.

* *Bank Select and Program Change messages will not be transmitted for Parts whose Tx parameter (PERFORM/MIDI/MIDI) is turned off.*

Transmit Volume

If you want Volume messages to also be transmitted when you select a Performance, specify the desired volume here. If you do not want Volume messages to be transmitted, set this to OFF.

■ Making Settings for Each Part (PART)

PATCH

Select the Patch for each Part.

Group (Patch Group)

Select the group of the Patch (or Rhythm Set for Part 10).

USER: User memory

PR-A-C, E: Preset memory A-C, E

GM: Preset memory GM

XP-A-E: Wave Expansion Board A-E

* *It is not possible to select a group for a Wave Expansion Board that has not been installed.*

Number (Patch Number)

Specify the number of the Patch. The Patch name will be displayed in parentheses ().

SETTING

Make volume, pan, and pitch settings for each Part.

Level

Adjust the volume of each Part. Use this parameter to adjust the volume balance between Parts.

Pan

Adjust the stereo location of the Part. L64 is full left, 0 is center, and 63R is full right.

Coarse (Coarse Tune)

Adjust the pitch of the Part in semitone steps (-4+4 octaves).

Fine (Fine Tune)

Adjust the pitch of the Part in 1-cent steps (-50+50 cents).

* *One cent is 1/100th of a semitone.*

RESERVE (Voice Reserve)

Voice Reserve

This setting determine how many voices will be reserved for each Part when more than 64 simultaneous voices are requested.

* *It is not possible to make Voice Reserve settings that would cause the total of all Parts to be greater than 64 voices. The number of remaining voices available is indicated at the right of the parameter name (rest=). Keep this in mind as you make settings.*

■ Confirming MIDI Information for Each Part (INFO)

INFO (Part Information)

The displays in this group allow you to check various settings such as MIDI message reception status for each Part. This is convenient when you need to check that the sound source is responding correctly to messages from the keyboard or external MIDI controller.

Mod (Modulation Information)

Breath (Breath Information)

Foot (Foot Information)

Vol (Volume Information)

Pan (Pan Information)

Exp (Expression Information)

Hold (Hold 1 Information)

Bend (Bender Information)

Aft (Aftertouch Information)

Sys1 (System Controller 1 Information)

The MIDI message specified as the Control 1 parameter (SYSTEM/CONTROL/SYS-CTRL ASSIGN)

Sys2 (System Controller 2 Information)

The MIDI message specified as the Control 2 parameter (SYSTEM/CONTROL/SYS-CTRL ASSIGN)

Voices (Voice Information)

The number of voices used

MIDI Message Transmission

When you modify a value (other than Voice) in the INFO display, the MIDI message of the modified value will be transmitted to the internal sound source and to external MIDI devices. The way in which the message will be transmitted will depend on the settings of the currently selected Performance.

If you have selected a Single-type Performance, the MIDI message will be transmitted to the specified Part, and will simultaneously be transmitted to external MIDI devices on the MIDI channel of that Part.

If you have selected a Layer-type Performance, the MIDI message will be transmitted to all Parts whose Tx parameter (PERFORM/MIDI/MIDI) is turned on, and will also be transmitted to external MIDI devices on the MIDI channel of each of these Parts.

Functions of Rhythm Set Parameters

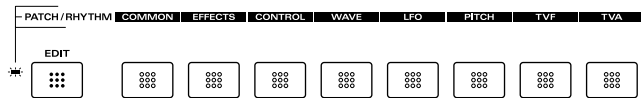

■ Naming a Rhythm Set (COMMON)

RHYTHM NAME (Rhythm Set Name)

You can assign a name of up to 12 characters to a Rhythm Set.

* For details on assigning names, refer to “Assigning a Name” (p. 46).

■ Setting Effects for a Rhythm Tone (EFFECTS)

* Rhythm Sets use the effect settings of the Performance currently selected in Performance mode. You can modify the Performance effect settings from inside Rhythm Set mode, but they are not stored as Rhythm Set settings. If you wish to keep the effect settings, you need to store them as Performance settings.

OUTPUT

Specify the output for each key.

Output Assign (Output Assign/Output Level)

For the output of each key, specify whether or not it will be sent through Multi-Effects, and adjust the volume level.

MIX: output to the OUTPUT jack without passing through Multi-Effects.

EFX: output to the OUTPUT jack after passing through Multi-Effects.

Chorus (Chorus Send Level)

Adjust the amount of Chorus for each key.

Reverb (Reverb Send Level)

Adjust the amount of Reverb for each key.

PERFORM EFX TYPE

(Performance EFX Type)

* If EFX Source has been set to use the EFX parameter settings of the Patch assigned to one of the Parts, the Part number will be shown in the upper left of the display.

Type (EFX Type)

Select the type of EFX. For details refer to “Multi-Effects Types (EFX Parameter)” (p. 93).

* If you have selected the EFX parameter settings of one of the Patches assigned to a Part as the EFX Source, the EFX Type of that Patch will be displayed.

Source (EFX Source)

Select the EFX parameter settings that will be used by the Performance. If you wish to use the EFX parameter settings of the Performance, select PERFORM. If you wish to use the EFX parameter settings of the Patch assigned to one of the Parts, select the Part number.

When the EFX Parameter Settings of a Patch Are Selected

When the EFX parameter settings of a Patch are selected, those settings will be displayed in the EFX parameter setting display of the Performance, and you will be able to modify them. If you wish to keep the Patch EFX parameter settings that you modify, rewrite the Patch settings. The modified Patch EFX parameter settings will be lost if you select a different Patch.

PERFORM EFX PRM (Performance EFX Parameters)

The EFX parameters for the selected EFX Type will be displayed. For details refer to “Multi-Effects Types (EFX Parameter)” (p. 93).

* If EFX Source has been set to use the EFX parameter settings of the Patch assigned to one of the Parts, the Part number will be shown in the upper left of the display.

PERFORM EFX OUT (Performance EFX Output)

These parameters specify the output for the keys for which EFX was selected in Output Assign.

* For keys which have an Output Assign setting of MIX, the settings of this display will be ignored.

Mix Out (EFX Output Level)

Adjust the volume of the direct sound and Multi-Effects sound.

Chorus (Chorus Send Level)

Adjust the amount of Chorus applied to the sound that passes through Multi-Effects.

Reverb (Reverb Send Level)

Adjust the amount of Reverb applied to the sound that passes through Multi-Effects.

PERFORM EFX CTRL (Performance EFX control)

Use this parameter when you wish to use a specific controller to control an EFX parameter. The types of EFX parameters available for control will depend on the EFX type. For details refer to “Multi-Effects Types (EFX Parameter)” (p. 93). The upper line of the display will show the EFX parameter to be controlled. For each EFX parameter you can specify the EFX Control Source and the EFX Control Depth.

EFX Control Source 1, 2

The MIDI controllers that can be used are shown below. If you wish to use a controller that is common to all Patches, or a controller that cannot be selected here, first select SYS-CTRL1 or SYS-CTRL2, and then use the Control 1/2 parameter (SYSTEM/CONTROL/SYS-CTRL ASSIGN) to select the controller.

- OFF:** a controller will not be used
- SYS-CTRL1:** System controller (Control 1)
- SYS-CTRL2:** System controller (Control 2)
- MODULATION:** Modulation (MIDI controller number 1)
- BREATH:** Breath (MIDI controller number 2)
- FOOT:** Foot (MIDI controller number 4)
- VOLUME:** Volume (MIDI controller number 7)
- PAN:** Pan (MIDI controller number 10)
- EXPRESSION:** Expression (MIDI controller number 11)
- PITCH BEND:** Pitch bend
- AFTERTOUC:** Aftertouch

EFX Control Depth 1, 2

Adjust the amount of change that will occur in response to controller movement. Higher values will result in greater change. Negative (-) values will invert the direction of the change.

PERFORM CHORUS

Make settings for the Chorus effect of the Performance.

Rate (Chorus Rate)

Adjust the speed of modulation for the chorus.

Depth (Chorus Depth)

Adjust the depth of modulation for the chorus.

Delay (Chorus Pre Delay)

Adjust the time delay from when the direct sound begins until the chorus sound is heard. Higher values will create a more spacious sound.

Fbk (Chorus Feedback Level)

Adjust the amount of chorus sound that is returned (fed back) into the chorus. Higher values will create a more intense effect.

Level (Chorus Level)

Adjust the volume level of the chorus sound.

Out (Chorus Output Assign)

Select the way in which the Chorus and Reverb are connected.

MIX: The Chorus sound and the Reverb sound are mixed.

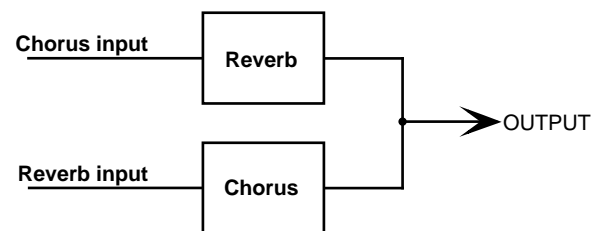

REV: Apply reverb to the chorus sound.

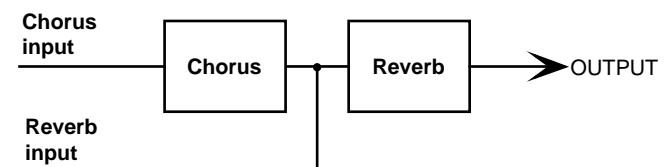

M+R: Mix the chorus sound to which reverb is not applied and the chorus sound to which reverb is applied.

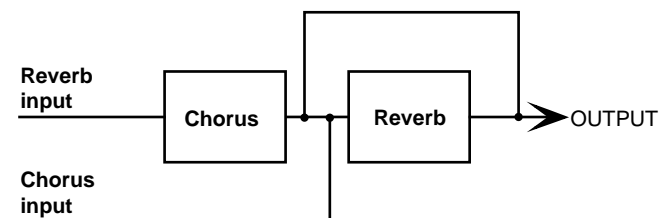

PERFORM REVERB

Make settings for the Reverb effect of the Performance.

Type (Reverb/Delay Type)

Select the type of Reverb effect.

- ROOM1:** dense reverb with short decay
- ROOM2:** sparse reverb with short decay
- STAGE1:** reverb with greater late reverberation
- STAGE2:** reverb with strong early reflections
- HALL1:** reverb with clear reverberance
- HALL2:** reverb with rich reverberance
- DELAY:** a conventional delay
- PAN-DLY:** a delay with echoes that move left and right

Time (Reverb/Delay Time)

Adjust the time of the reverberation. If you have selected DELAY or PAN-DLY, this parameter will adjust the time delay from the original sound until the first echo will sound.

Fbk (Delay Feedback Level)

Adjust the amount of delayed sound that is returned (fed back) to the delay. Higher values result in more delay repeats.

* *If you have selected any one of the Reverb types (ROOM1–HALL2), this parameter has no effect.*

HF Damp (Reverb/Delay HF Damp)

Adjust the frequency above which the reverberant sound will be cut. As the frequency is set lower, more of the high frequencies will be cut, resulting in a softer and more muted reverberance. If you do not want the high frequencies to be cut, set this parameter to BYPASS.

Level (Reverb/Delay Level)

Adjust the volume of the reverberant (or delayed) sound.

■ Controlling How a Rhythm Tone will Sound with Controllers (CONTROL)

The parameters in this group determine how the controllers function and how instruments in a Rhythm Set will sound.

CONTROL

These parameters determine how each note is controlled.

Bend Range

Specify the amount of pitch change (in semitones) that will occur when the Pitch Bend Lever is moved (maximum +1 octave).

Env Mode (Envelope Mode)

When a loop-type Wave is selected, it will normally continue to sound as long as the key is pressed. If you want it to decay naturally even if the key remains pressed, set this to NO-SUS.

* *If a one-shot type Wave is selected, it will not sustain even if this parameter is set to SUSTAIN.*

Mute Group

The Mute Group function lets you specify that certain Rhythm Tones not be allowed to sound simultaneously. Taking the example of an acoustic drum set, it is obviously impossible for an open hi-hat and a closed hi-hat sound to occur simultaneously. To simulate this type of situation on the XP-30, set each hi-hat sound to the same Mute Group number. Up to 31 Mute Groups can be used. If you do not want a Rhythm Tone to use a Mute Group, turn it OFF.

RxSWITCH (Receive Switch)

These parameters determine how each key will receive Volume / Pan / Hold 1 MIDI messages.

Volume (Receive Volume Switch)

If you want Volume messages to be received, turn this parameter ON. If not, turn it OFF.

* *In order for Volume messages to be received, the Volume parameter (PERFORM/MIDI/RxSWITCH) must also be turned ON for Part 10 of the currently selected Performance.*

Pan (Receive Pan Control Switch)

Specify how Pan messages will be received.

OFF: Not received.

CONT: Whenever a Pan message is received, it will immediately change the stereo location of the sound.

KEY-ON: The stereo location of the sound will be changed when the next note is played. If a Pan message is received while a note is sounding, the current stereo location will not change until the next note. In this case, the stereo location will change only for the note played later, and the currently sounding note will not move.

Hold-1 (Receive Hold 1 Switch)

If you want Hold 1 messages to be received, turn this parameter ON. If not, turn it OFF.

* *In order for Hold 1 messages to be received, the Hold-1 parameter (PERFORM/MIDI/RxSWITCH) must also be turned ON for Part 10 of the currently selected Performance.*

■ Modifying Waveform of a Rhythm Tone (WAVE)

Make settings for the basic waveform (Wave) of the Rhythm Tone assigned to each key.

WAVE

Group (Wave Group)

Select the Group of the Wave.

INT-A, B: Internal A, B

EXP-A–E: Wave Expansion Boards A–E

* *It is not possible to select a Group of a Wave Expansion Board that is not installed.*

Number (Wave Number)

Select the Wave number. The name of the Wave will be displayed in parentheses ().

Gain (Wave Gain)

Adjust the gain (volume boost) of the Wave. The setting range is -6–+12 dB, in steps of 6 dB. An increase of 6 dB doubles the gain.

Switch (Key Switch)

Turn this ON for keys you wish to sound, and OFF for keys you do not wish to sound.

■ Modifying Pitch of a Rhythm Tone (PITCH)

This group contains parameters that affect the pitch of the Rhythm Tone for each key.

PITCH

Specify the basic pitch for the Rhythm Tone.

Coarse (Coarse Tune)

Select the key corresponding to the pitch at which you wish to sound the Rhythm Tone.

Fine (Fine Tune)

Adjust the pitch in 1-cent steps (-50+50 cents).

* One cent is 1/100th of a semitone.

Random (Random Pitch Depth)

If you want the pitch to change randomly each time you press a key, specify the width of the change. If you do not want random pitch change, set this parameter to 0. The value is in units of 1 cent.

Env Depth (Pitch Envelope Depth)

Adjust the effect of the Pitch Envelope. Higher settings will result in greater change. Negative (-) settings will invert the envelope.

PCH VELOCITY

Specify how key velocity will change the effect of the Pitch Envelope.

Velocity Sens (Pitch Envelope Velocity Sensitivity)

Use this parameter if you want key velocity to change the effect of the Pitch Envelope. Higher settings will result in a greater difference between strongly and softly played notes. Negative (-) settings will invert the change.

Velocity Time

(Pitch Envelope Time Velocity Sensitivity)

Use this parameter if you want key velocity to change the overall time of the Pitch Envelope. Higher settings will result in a greater time difference between strongly and softly played notes. Negative (-) settings will invert the change.

PCH ENVELOPE

Make settings for the Pitch Envelope (changes in pitch over time).

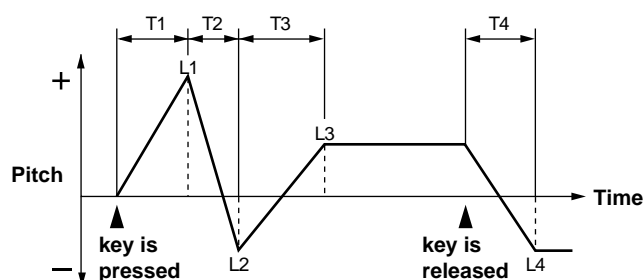

T1-4 (Pitch Envelope Time 1-4)

Specify the time over which the pitch will change from one point to the next.

L1-4 (Pitch Envelope Level 1-4)

Specify the pitch change for each point relative to the basic pitch.

■ Changing the Tone (Filter) of a Rhythm Tone (TVF)

The TVF (Time Variant Filter) uses a filter to modify the frequency characteristics of the sound.

FILTER

Make TVF filter settings.

Type (Filter Type)

Select the filter type.

- OFF:** filter not used.
- LPF (Low Pass Filter):** Cut the frequencies above the Cutoff Frequency. This is the most common type of filter used in synthesizers.
- BPF (Band Pass Filter):** Pass only the frequencies in the area of the Cutoff Frequency.
- HPF (High Pass Filter):** Cut the frequencies below the Cutoff Frequency.
- PKG (Peaking Filter):** Emphasize the frequencies in the area of the Cutoff Frequency.

Cutoff (Cutoff Frequency)

Set the basic frequency of the filter.

Resonance

Emphasize the frequencies in the area of the Cutoff Frequency. For some settings, excessive levels can cause oscillation and distortion.

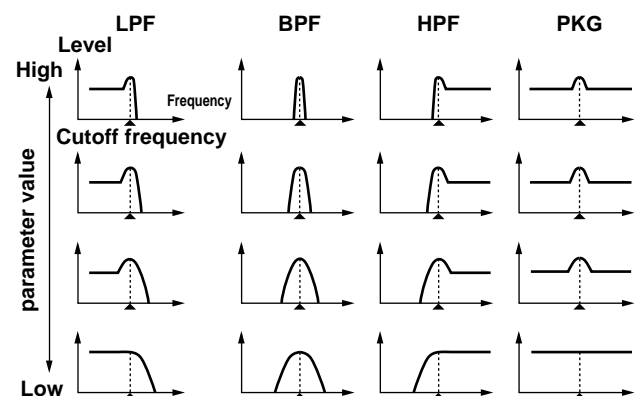

Env Depth (TVF Envelope Depth)

Adjust the depth of the TVF envelope. Higher settings will result in greater change. Negative (-) values will invert the envelope.

TVF VELOCITY

V-Sens (TVF Envelope Velocity Sensitivity)

Use this parameter when you want velocity to affect the TVF Envelope. Higher settings will result in a greater difference between strongly and softly played notes. Negative (-) settings will invert the effect.

V-Time (TVF Envelope Time Velocity Sensitivity)

Use this parameter when you want velocity to affect the time of the TVF envelope. Higher settings will result in a greater time difference between strongly and softly played notes. Negative (-) settings will invert the effect.

V-Resonance (Resonance Velocity Sensitivity)

Use this parameter when you want velocity to affect the Resonance. Higher settings will result in a greater difference between strongly and softly played notes. Negative (-) settings will invert the effect.

TVF ENVELOPE

These parameters set the TVF envelope (the way in which the cutoff frequency will change over time).

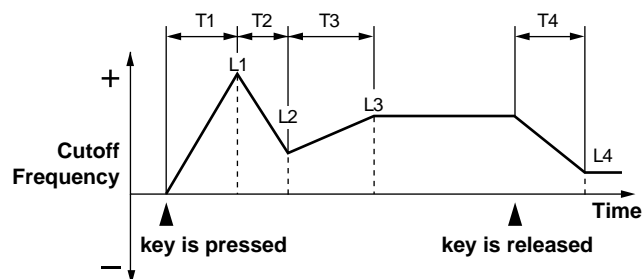

T1-T4 (TVF Envelope Time 1-4)

Set the times over which the cutoff frequency will move from one point to the next.

L1-L4 (TVF Envelope Level 1-4)

Set the cutoff frequency levels for each point, relative to the basic cutoff frequency.

■ Changing the Volume and Stereo Location of a Rhythm Tone (TVA)

The TVA (Time Variant Amplifier) controls volume changes and stereo location.

TVA

Level

Adjust the basic volume of the Rhythm Tone. Use this parameter to adjust the volume balance between Rhythm Tones.

Pan

Adjust the pan (stereo location) of the Rhythm Tone. L64 is full left, 0 is center, and 63R is full right.

Random (Random Pan Depth)

Use this parameter when you want the stereo location to change randomly each time you press a key. If you do not want the stereo location to change randomly, set this to 0.

Alternate (Alternate Pan Depth)

Use this parameter when you want the stereo location to alternate between left and right each time you press a key. Higher values will result in a greater width of change. L or R values can be set, and this will reverse the left/right order of the panning. If you want to alternate the pan position of two Rhythm Tones, set them to opposite L and R settings.

TVA VELOCITY

Specify how keyboard velocity will affect the time of the TVA envelope.

Velocity Sens (TVA Envelope Velocity Sensitivity)

Use this parameter when you want velocity to affect the TVA Envelope. Higher settings will result in a greater difference between strongly and softly played notes. Negative (-) settings will invert the effect.

Velocity Time

(TVA Envelope Time Velocity Sensitivity)

Use this parameter when you want velocity to affect the time of the TVA envelope. Higher settings will result in a greater time difference between strongly and softly played notes. Negative (-) settings will invert the effect.

TVA ENVELOPE

These parameters make settings for the TVA envelope (changes over time in the TVA level).

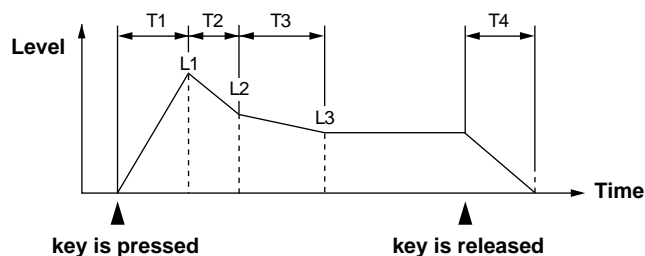

T1-T4 (TVA Envelope Time 1-4)

Adjust the time over which the volume changes from one point to the next.

L1-L3 (TVA Envelope Level 1-3)

Adjust the volume level of each point relative to the basic TVA level.

Multi-Effects Types (EFX Parameter)

Multi-Effects provides 40 types of effect. Some of these consist of two different effects connected in series or parallel.

* Parameters marked with a sharp “#” can be controlled using a specified controller (Two setting items will change simultaneously for “#1” and “#2”). Settings in the Patch or Performance EFX Control display (PATCH/EFFECTS/PATCH EFX CTRL or PERFORM/EFFECTS/PERFORM EFX CTRL) will determine how these parameters are controlled.

1: STEREO-EQ (Stereo Equalizer)

This is a four-band stereo equalizer (low, mid x 2, high).

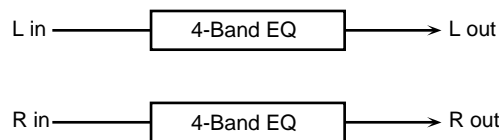

LowFreq (Low Frequency)

Select the frequency of the low range (200 Hz/400 Hz).

LowGain (Low Gain)

Adjust the gain of the low frequency.

Hi Freq (High Frequency)

Select the frequency of the high range (4000 Hz/8000 Hz).

Hi Gain (High Gain)

Adjust the gain of the high frequency.

P1 Freq (Peaking 1 Frequency)

Adjust the frequency of Peaking 1 (mid range).

P1 Q (Peaking 1 Q)

This parameter adjusts the width of the area around the Peaking 1 Frequency that will be affected by the Gain setting. Higher values of Q will result in a narrower area being affected.

P1 Gain (Peaking 1 Gain)

Adjust the gain for the area specified by the Peaking 1 Frequency and Q settings.

P2 Freq (Peaking 2 Frequency)

Adjust the frequency of Peaking 2 (mid range).

P2 Q (Peaking 2 Q)

This parameter adjusts the width of the area around the Peaking 2 Frequency that will be affected by the Gain setting. Higher values of Q will result in a narrower area being affected.

P2 Gain (Peaking 2 Gain)

Adjust the gain for the area specified by the Peaking 2 Frequency and Q settings.

Level (Output Level)

Adjust the output level.

2: OVERDRIVE

This effect creates a soft distortion similar to that produced by vacuum tube amplifiers.

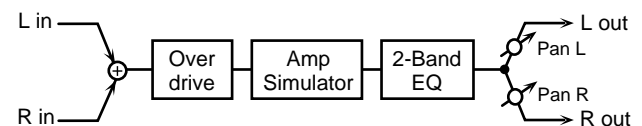

Drive

Adjust the degree of distortion. The volume will change together with the degree of distortion.

Level (Output Level)

Adjust the output level.

LowGain (Low Gain)

Adjust the gain of the low frequency range.

Hi Gain (High Gain)

Adjust the gain of the high frequency range.

Amp Type (Amp Simulator Type)

Select the type of guitar amp.

SMALL: small amp

BUILT-IN: single-unit type amp

2-STACK: large double stack amp

3-STACK: large triple stack amp

Pan (Output Pan)

Adjust the stereo location of the output sound. L64 is far left, 0 is center, and 63R is far right.

3: DISTORTION

This effect produces a more intense distortion than Overdrive.

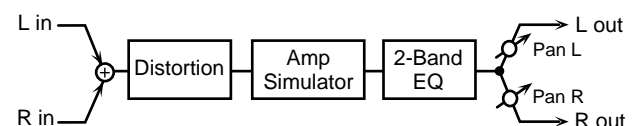

Drive

Adjust the degree of distortion. The volume will change together with the degree of distortion.

Level (Output Level)

Adjust the output level.

LowGain (Low Gain)

Adjust the gain of the low frequency range.

Hi Gain (High Gain)

Adjust the gain of the high frequency range.

Amp Type (Amp Simulator Type)

Select the type of guitar amp.

SMALL: small amp

BUILT-IN: single-unit type amp

2-STACK: large double stack amp

3-STACK: large triple stack amp

Pan (Output Pan)

Adjust the stereo location of the output sound. L64 is far left, 0 is center, and 63R is far right.

4: PHASER

A phaser adds a phase-shifted sound to the original sound, producing a twisting modulation that creates spaciousness and depth.

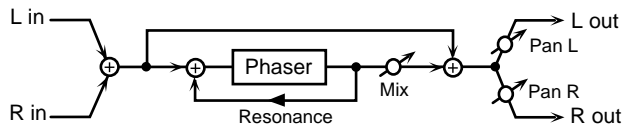

Manual

Adjust the basic frequency from which the sound will be modulated.

Rate

Adjust the frequency (period) of modulation.

Depth

Adjust the depth of modulation.

Res (Resonance)

Adjust the amount of feedback for the phaser.

Mix (Mix Level)

Adjust the ratio with which the phase-shifted sound is combined with the direct sound.

Pan (Output Pan)

Adjust the stereo location of the output sound. L64 is far left, 0 is center, and 63R is far right.

Level (Output Level)

Adjust the output level.

5: SPECTRUM

Spectrum is a type of filter which modifies the timbre by boosting or cutting the level at specific frequencies. It is similar to an equalizer, but has 8 frequency points fixed at locations most suitable for adding character to the sound.

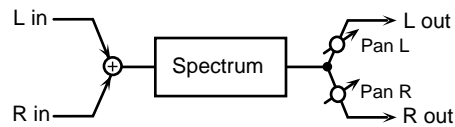

Band 1 (Band 1 Gain)

Adjust the 250 Hz level.

Band 2 (Band 2 Gain)

Adjust the 500 Hz level.

Band 3 (Band 3 Gain)

Adjust the 1000 Hz level.

Band 4 (Band 4 Gain)

Adjust the 1250 Hz level.

Band 5 (Band 5 Gain)

Adjust the 2000 Hz level.

Band 6 (Band 6 Gain)

Adjust the 3150 Hz level.

Band 7 (Band 7 Gain)

Adjust the 4000 Hz level.

Band 8 (Band 8 Gain)

Adjust the 8000 Hz level.

Q

Simultaneously adjust the width of the adjusted areas for all the frequency bands.

Pan (Output Pan)

Adjust the stereo location of the output sound. L64 is far left, 0 is center, and 63R is far right.

Level (Output Level)

Adjust the output level.

6: ENHANCER

The Enhancer controls the overtone structure of the high frequencies, adding sparkle and tightness to the sound.

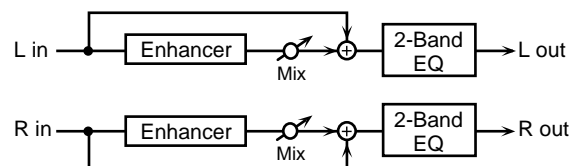

Sens (Sensitivity)

Adjust the sensitivity of the enhancer.

Mix (Mix Level) #

Adjust the ratio with which the overtones generated by the enhancer are combined with the direct sound.

LowGain (Low Gain)

Adjust the gain of the low frequency range.

Hi Gain (High Gain)

Adjust the gain of the high frequency range.

Level (Output Level)

Adjust the output level.

7: AUTO-WAH

The Auto Wah cyclically controls a filter to create cyclic change in timbre.

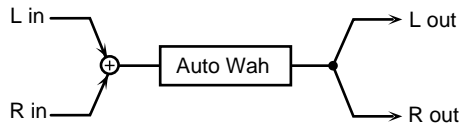

Filter (Filter Type)

Select the type of filter.

LPF: The wah effect will be applied over a wide frequency range.

BPF: The wah effect will be applied over a narrow frequency range.

Sens

Adjust the sensitivity with which the filter is controlled.

Manual #

Adjust the center frequency from which the effect is applied.

Peak

Adjust the amount of the wah effect that will occur in the area of the center frequency. Lower settings will cause the effect to be applied in a broad area around the center frequency. Higher settings will cause the effect to be applied in a more narrow range.

Rate #

Adjust the frequency of the modulation.

Depth

Adjust the depth of the modulation.

Level (Output Level)

Adjust the output level.

8: ROTARY

The Rotary effect simulates the sound of the rotary speakers often used with the electric organs of the past. Since the movement of the high range and low range rotors can be set independently, the unique type of modulation characteristic of these speakers can be simulated quite closely. This effect is most suitable for electric organ Patches.

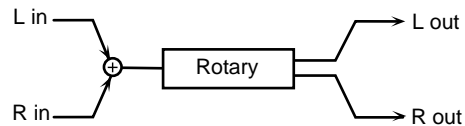

LowSlow (Low Frequency Slow Rate)

Adjust the slow speed (SLOW) of the low frequency rotor.

LowFast (Low Frequency Fast Rate)

Adjust the fast speed (FAST) of the low frequency rotor.

LowAccl (Low Frequency Acceleration)

Adjust the time it takes the low frequency rotor to reach the newly selected speed when switching from fast to slow (or slow to fast) speed. Lower values will require longer times.

Low Lvl (Low Frequency Level)

Adjust the volume of the low frequency rotor.

Hi Slow (High Frequency Slow Rate)

Adjust the slow speed (SLOW) of the high frequency rotor.

Hi Fast (High Frequency Fast Rate)

Adjust the fast speed (FAST) of the high frequency rotor.

Hi Accl (High Frequency Acceleration)

Adjust the time it takes the high frequency rotor to reach the newly selected speed when switching from fast to slow (or slow to fast) speed. Lower values will require longer times.

Hi Lvl (High Frequency Level)

Adjust the volume of the high frequency rotor.

Separation

Adjust the spatial dispersion of the sound.

Speed #

Simultaneously switch the rotational speed of the low frequency rotor and high frequency rotor.

SLOW: Slow down the rotation to the specified speed (the Low Slow / Hi Slow values).

FAST: Speed up the rotation to the specified speed (the Low Fast / Hi Fast values).

Level (Output Level) #

Adjust the output level.

9: COMPRESSOR

The Compressor flattens out high levels and boosts low levels, smoothing out unevenness in volume.

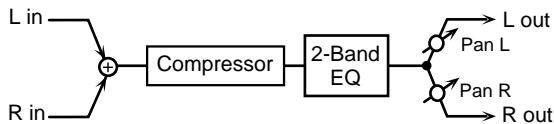

Attack

Adjust the attack time of an input sound.

Sustain

Adjust the time over which low level sounds are boosted until they reach the specified volume.

Post Gain

Adjust the output gain.

LowGain

Adjust the low frequency gain.

Hi Gain

Adjust the high frequency gain.

Pan (Output Pan)

Adjust the stereo location of the output sound. L64 is far left, 0 is center, and 63R is far right.

Level (Output Level)

Adjust the output level.

10: LIMITER

The Limiter compresses signals that exceed a specified volume level, preventing distortion from occurring.

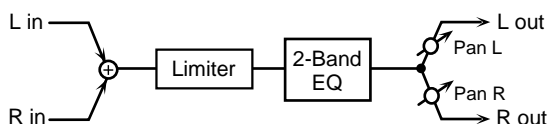

Thresh (Threshold Level)

Adjust the volume at which compression will begin.

Ratio (Compression Ratio)

Adjust the compression ratio.

Release (Release Time)

Adjust the time from when the volume falls below the Threshold Level until compression is no longer applied.

Gain (Post Gain)

Adjust the output gain.

LowGain

Adjust the low frequency gain.

Hi Gain

Adjust the high frequency gain.

Pan (Output Pan)

Adjust the stereo location of the output sound. L64 is far left, 0 is center, and 63R is far right.

Level (Output Level)

Adjust the output level.

11: HEXA-CHORUS

Hexa-chorus uses a six-phase chorus (six layers of chorused sound) to give richness and spatial spread to the sound.

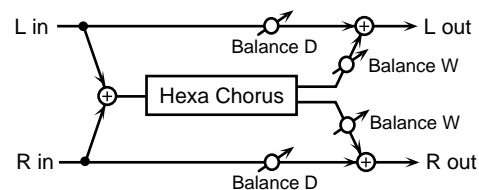

Pre Dly (Pre Delay Time)

Adjust the time delay from when the direct sound begins until the chorus sound is heard.

Rate

Adjust the rate of modulation.

Depth

Adjust the depth of modulation.

Dly Dev (Pre Delay Deviation)

Pre Delay determines the time from when the direct sound begins until the processed sound is heard. Pre Delay Deviation adjusts the differences in Pre Delay between each chorus sound.

Dpt Dev (Depth Deviation)

Adjust the difference in modulation depth between each chorus sound.

Pan Dev (Pan Deviation)

Adjust the difference in stereo location between each chorus sound. With a setting of 0, all chorus sounds will be in the center. With a setting of 20, each chorus sound will be spaced at 60 degree intervals relative to the center.

Balance (Effect Balance)

Adjust the volume balance between the direct sound and the chorus sound. With a setting of D100:0W only the direct sound will be output, and with a setting of D0:100W only the chorus sound will be output.

Level (Output Level)

Adjust the output level.

12: TREMOLO-CHORUS

Tremolo Chorus is a chorus effect with added Tremolo (cyclic modulation of volume).

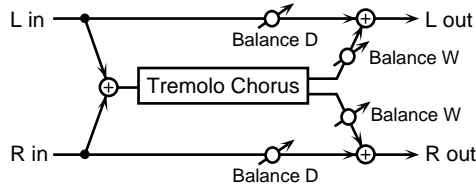

Pre Dly (Pre Delay Time)

Adjust the time delay from when the direct sound begins until the chorus sound is heard.

ChoRate (Chorus Rate)

Adjust the modulation speed of the chorus effect.

ho Dpt (Chorus Depth)

Adjust the modulation depth of the chorus effect.

Phase (Tremolo Phase)

Adjust the spread of the tremolo effect.

TrmRate (Tremolo Rate)

Adjust the modulation speed of the tremolo effect.

Trm Sep (Tremolo Separation)

Adjust the spread of the tremolo effect.

Balance (Effect Balance)

Adjust the volume balance between the direct sound and the tremolo chorus sound. With a setting of D100:0W only the direct sound will be output, and with a setting of D0:100W only the tremolo chorus sound will be output.

Level (Output Level)

Adjust the output level.

13: SPACE-D

Space-D is a multiple chorus that applies two-phase modulation in stereo. It gives no impression of modulation, but produces a transparent chorus effect.

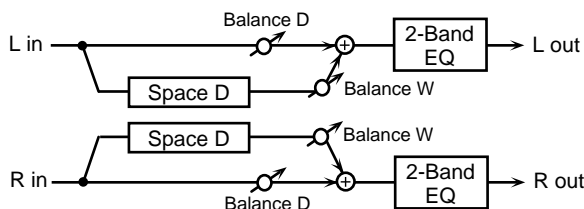

Pre Dly (Pre Delay Time)

Adjust the time delay from when the direct sound begins until the processed sound is heard.

Rate

Adjust the rate of modulation.

Depth

Adjust the depth of modulation.

Phase

Adjust the spatial spread of the sound.

LowGain

Adjust the gain of the low frequency range.

Hi Gain

Adjust the gain of the high frequency range.

Balance (Effect Balance)

Adjust the volume balance between the direct sound and the chorus sound. With a setting of D100:0W only the direct sound will be output, and with a setting of D0:100W only the chorus sound will be output.

Level (Output Level)

Adjust the output level.

14: STEREO-CHORUS

This is a stereo chorus. A filter is provided so that you can adjust the timbre of the chorus sound.

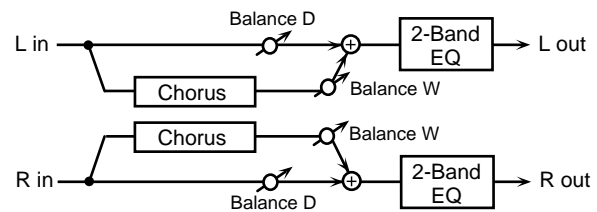

Pre Dly (Pre Delay Time)

Adjust the time delay from when the direct sound begins until the processed sound is heard.

Rate

Adjust the rate of modulation.

Depth

Adjust the depth of modulation.

Phase

Adjust the spatial spread of the sound.

Filter (Filter Type)

Select the type of filter.

OFF: a filter will not be used

LPF: cut the frequency range above the cutoff frequency

HPF: cut the frequency range below the cutoff frequency

Cutoff (Cutoff Frequency)

Adjust the basic frequency of the filter.

LowGain

Adjust the gain of the low frequency range.

Hi Gain

Adjust the gain of the high frequency range.

Balance (Effect Balance)

Adjust the volume balance between the direct sound and the chorus sound. With a setting of D100:0W only the direct sound will be output, and with a setting of D0:100W only the chorus sound will be output.

Level (Output Level)

Adjust the output level.

15: STEREO-FLANGER

This is a stereo flanger. (The LFO has the same phase for left and right.) It produces a metallic resonance that rises and falls like a jet airplane taking off or landing. A filter is provided so that you can adjust the timbre of the flanged sound.

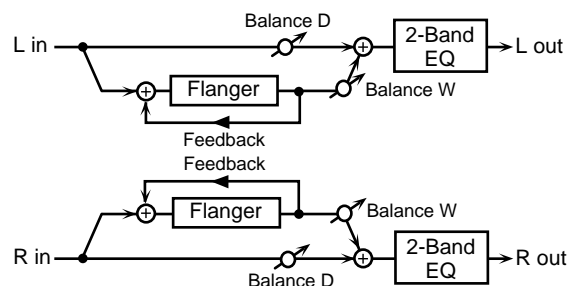

Pre Dly (Pre Delay Time)

Adjust the time delay from when the direct sound begins until the flanger sound is heard.

Rate

Adjust the rate of modulation.

Depth

Adjust the depth of modulation.

Fbk (Feedback Level)

Adjust the amount (%) of the processed sound that is returned (fed back) into the input. Positive (+) settings will return the sound in phase, and negative (-) settings will return the sound in reverse phase.

Phase

Adjust the spatial spread of the sound.

Filter Type

Select the type of filter.

OFF: a filter will not be used

LPF: cut the frequency range above the cutoff frequency

HPF: cut the frequency range below the cutoff frequency

Cutoff (Cutoff Frequency)

Adjust the basic frequency of the filter.

LowGain

Adjust the gain of the low frequency range.

Hi Gain

Adjust the gain of the high frequency range.

Balance (Effect Balance)

Adjust the volume balance between the direct sound and the flanger sound. With a setting of D100:0W only the direct sound will be output, and with a setting of D0:100W only the flanger sound will be output.

Level (Output Level)

Adjust the output level.

16: STEP-FLANGER

The Step Flanger effect is a flanger in which the flanger pitch changes in steps. The speed at which the pitch changes can also be specified in terms of a note-value of a specified tempo.

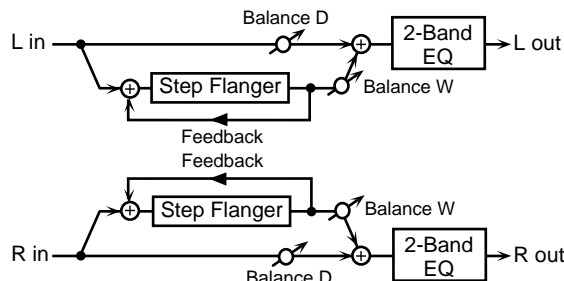

Pre Dly (Pre Delay Time)

Adjust the time delay from when the direct sound begins until the flanger sound is heard.

Rate

Adjust the rate of modulation.

Depth

Adjust the depth of modulation.

Fbk (Feedback Level)

Adjust the amount (%) of the flanger sound that is returned (fed back) into the input. Negative (-) settings will invert the phase.

Phase

Adjust the spatial spread of the sound.

Step Rate

Adjust the rate (period) of pitch change. This parameter can be set as a note-value of a specified tempo. In this case, specify the value of the desired note.

When Step Rate is Set as a Note Value

As the specified tempo, you may use either the Patch Tempo, Performance Tempo, or the tempo clock of the XP-30's system.

If you want to use a fixed tempo in Patch mode (Tempo parameter setting), set the Source parameter (PATCH/COMMON/PATCH CLOCK) to PATCH and set the desired tempo.

If you want to use the system's tempo clock in Patch mode, set the Source parameter (PATCH/COMMON/PATCH CLOCK) to SYSTEM.

If you want to use a fixed tempo in Performance mode (Tempo parameter setting), set the Source parameter (PERFORM/COMMON/PERFORM CLOCK) to PERFORM and set the desired tempo.

If you want to use the system's tempo clock in Performance mode, set the Source parameter (PERFORM/COMMON/PERFORM CLOCK) to SYSTEM.

LowGain

Adjust the gain of the low frequency range.

Hi Gain

Adjust the gain of the high frequency range.

Balance (Effect Balance)

Adjust the volume balance between the direct sound and the flanger sound. With a setting of D100:0W only the direct sound will be output, and with a setting of D0:100W only the chorus sound will be output.

Level (Output Level)

Adjust the output level.

17: STEREO-DELAY

This is a stereo delay.

When Feedback Mode is NORMAL:

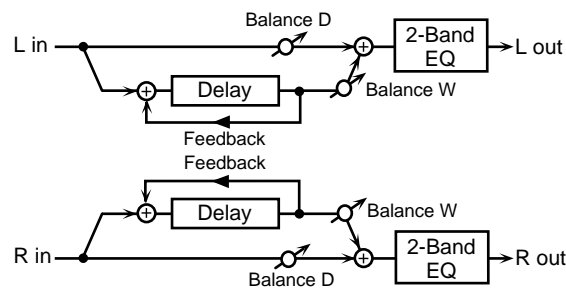

When Feedback Mode is CROSS:

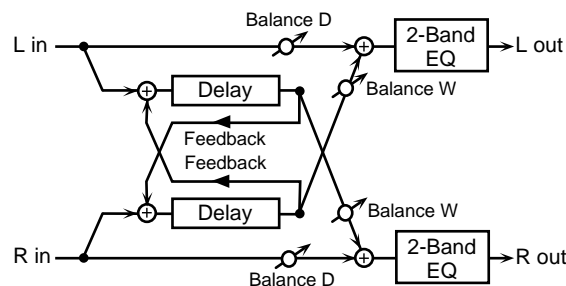

Delay L (Delay Time Left)

Adjust the time from the original sound until when the left delay sound is heard.

Delay R (Delay Time Right)

Adjust the time from the original sound until when the right delay sound is heard.

Fbk (Feedback Level) #

Adjust the proportion (%) of the delay sound that is fed back into the effect. Negative (-) settings will invert the phase.

Mode (Feedback Mode)

Select the way in which delay sound is fed back into the effect.

NORMAL: The left delay sound will be fed back into the left delay, and the right delay sound into the right delay.

CROSS: The left delay sound will be fed back into the right delay, and the right delay sound into the left delay.

Phase L (Feedback Phase Left)

Select the phase of the left delay sound.

NORMAL: Phase is not changed.

INVERT: Phase is inverted.

Phase R (Feedback Phase Right)

Select the phase of the right delay sound.

NORMAL: Phase is not changed.

INVERT: Phase is inverted.

HF Damp

Adjust the frequency above which sound fed back to the effect will be cut. If you do not want to cut the high frequencies of the feedback, set this parameter to BYPASS.

LowGain

Adjust the gain of the low frequency range.

Hi Gain

Adjust the gain of the high frequency range.

Balance (Effect Balance) #

Adjust the volume balance between the direct sound and the delay sound. With a setting of D100:0W only the direct sound will be output, and with a setting of D0:100W only the delay sound will be output.

Level (Output Level)

Adjust the output level.

18: MODULATION-DELAY

This effect adds modulation to the delayed sound, producing an effect similar to a flanger.

When Feedback Mode is NORMAL:

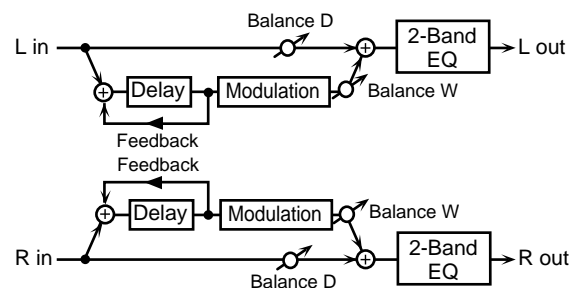

When Feedback Mode is CROSS:

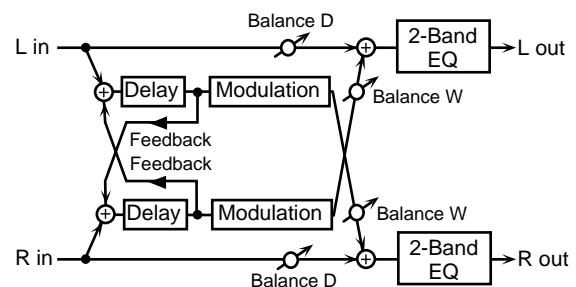

Delay L (Delay Time Left)

Adjust the time from the original sound until when the left delay sound is heard.

Chapter 3. Creating Your Own Sounds

Delay R (Delay Time Right)

Adjust the time from the original sound until when the right delay sound is heard.

Fbk (Feedback Level)

Adjust the proportion (%) of the delay sound that is fed back into the effect. Negative (-) settings will invert the phase.

Mode (Feedback Mode)

Select the way in which delay sound is fed back into the effect.

NORMAL: The left delay sound will be fed back into the left delay, and the right delay sound into the right delay.

CROSS: The left delay sound will be fed back into the right delay, and the right delay sound into the left delay.

Rate

Adjust the speed of the modulation.

Depth

Adjust the depth of the modulation.

Phase

Adjust the spatial spread of the sound.

HF Damp

Adjust the frequency above which sound fed back to the effect will be cut. If you do not want to cut the high frequencies of the feedback, set this parameter to BYPASS.

LowGain

Adjust the gain of the low frequency range.

Hi Gain

Adjust the gain of the high frequency range.

Balance (Effect Balance)

Adjust the volume balance between the direct sound and the modulation delay sound. With a setting of D100:0W only the direct sound will be output, and with a setting of D0:100W only the modulation delay sound will be output.

Level (Output Level)

Adjust the output level.

19: TRIPLE-TAP-DELAY

The Triple Tap Delay produces three delay sounds; center, left and right. The center delay time can be specified as a note value of a specified tempo.

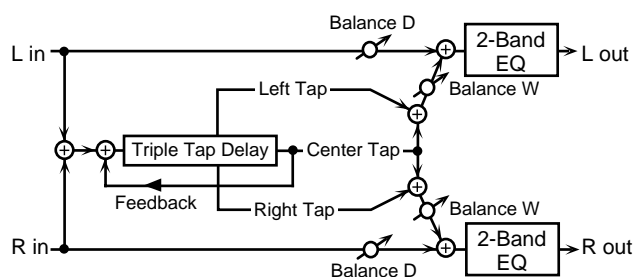

Delay C (Delay Time Center)

Delay L (Delay Time Left)

Delay R (Delay Time Right)

Adjust the time delay from the direct sound until when the delay sound is heard. This parameter can be set as a note-value of a specified tempo. In this case, specify the value of the desired note.

When Step Rate is Set as a Note Value

As the specified tempo, you may use either the Patch Tempo, Performance Tempo, or the tempo clock of the XP-30's system.

If you want to use a fixed tempo in Patch mode (Tempo parameter setting), set the Source parameter (PATCH/COMMON/PATCH CLOCK) to PATCH and set the desired tempo.

If you want to use the system's tempo clock in Patch mode, set the Source parameter (PATCH/COMMON/PATCH CLOCK) to SYSTEM.

If you want to use a fixed tempo in Performance mode (Tempo parameter setting), set the Source parameter (PERFORM/COMMON/PERFORM CLOCK) to PERFORM and set the desired tempo.

If you want to use the system's tempo clock in Performance mode, set the Source parameter (PERFORM/COMMON/PERFORM CLOCK) to SYSTEM.

Fbk (Feedback Level)

Adjust the proportion (%) of the delay sound that is fed back into the effect. Negative (-) settings will invert the phase.

Level C (Center Level)

Level L (Left Level)

Level R (Right Level)

Adjust the volume of each delay sound.

HF Damp

Adjust the frequency above which sound fed back to the effect will be cut. If you do not want to cut the high frequencies of the feedback, set this parameter to BYPASS.

LowGain

Adjust the gain of the low frequency range.

Hi Gain

Adjust the gain of the high frequency range.

Balance (Effect Balance)

Adjust the volume balance between the direct sound and the delay sound. With a setting of D100:0W only the direct sound will be output, and with a setting of D0:100W only the delay sound will be output.

Level (Output Level)

Adjust the output level.

20: QUADRUPLE-TAP-DELAY

The Quadruple Tap Delay has four delays. Each of the Delay Time parameters can be specified as a note length of the selected tempo.

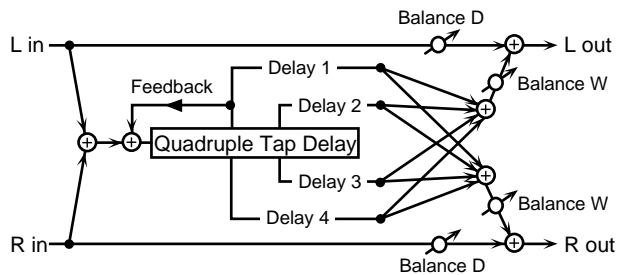

The stereo location of each delay sound is as follows.

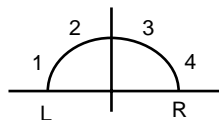

Delay 1 (Delay Time 1)

Delay 2 (Delay Time 2)

Delay 3 (Delay Time 3)

Delay 4 (Delay Time 4)

Adjust the time delay from the direct sound until when each delay sound is heard. These parameters can be set as a note-value of a specified tempo. In this case, specify the value of the desired note.

When Step Rate is Set as a Note Value

As the specified tempo, you may use either the Patch Tempo, Performance Tempo, or the tempo clock of the XP-30's system.

If you want to use a fixed tempo in Patch mode (Tempo parameter setting), set the Source parameter (PATCH/COMMON/PATCH CLOCK) to PATCH and set the desired tempo.

If you want to use the system's tempo clock in Patch mode, set the Source parameter (PATCH/COMMON/PATCH CLOCK) to SYSTEM.

If you want to use a fixed tempo in Performance mode (Tempo parameter setting), set the Source parameter (PERFORM/COMMON/PERFORM CLOCK) to PERFORM and set the desired tempo.

If you want to use the system's tempo clock in Performance mode, set the Source parameter (PERFORM/COMMON/PERFORM CLOCK) to SYSTEM.

Level 1

Level 2

Level 3

Level 4

Adjust the volume of each delay sound.

Fbk (Feedback Level) #

Adjust the proportion (%) of the delay sound that is fed back into the effect. Negative (-) settings will invert the phase.

HF Damp

Adjust the frequency above which sound fed back to the effect will be cut. If you do not want to cut the high frequencies of the feedback, set this parameter to BYPASS.

Balance (Effect Balance) #

Adjust the volume balance between the direct sound and the delay sound. With a setting of D100:0W only the direct sound will be output, and with a setting of D0:100W only the delay sound will be output.

Level (Output Level)

Adjust the output level.

21: TIME-CONTROL-DELAY

This effect allows you to use a specified controller (the controller selected in EFX Control Source) to control the delay time and pitch in realtime. Lengthening the delay will lower the pitch, and shortening it will raise the pitch.

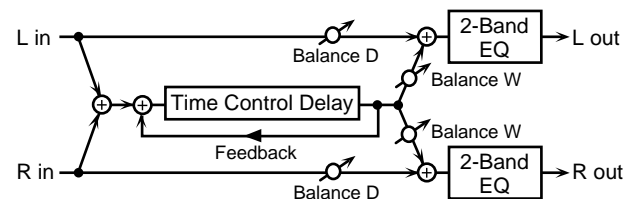

Delay (Delay time) #

Adjust the time delay from the direct sound until when each delay sound is heard.

Accel (Acceleration)

This parameter adjusts the time over which the Delay Time will change from the current setting to a newly specified setting. The rate of change for the Delay Time directly affects the rate of pitch change.

Fbk (Feedback Level) #

Adjust the proportion (%) of the delay sound that is fed back into the effect. Negative (-) settings will invert the phase.

HF Damp

Adjust the frequency above which sound fed back to the effect will be cut. If you do not want to cut the high frequencies of the feedback, set this parameter to BYPASS.

Pan (Output Pan)

Adjust the stereo location of the delay sound. L64 is far left, 0 is center, and 63R is far right.

LowGain

Adjust the gain of the low frequency range.

Hi Gain

Adjust the gain of the high frequency range.

Balance (Effect Balance)

Adjust the volume balance between the direct sound and the delay sound. With a setting of D100:0W only the direct sound will be output, and with a setting of D0:100W only the delay sound will be output.

Level (Output Level)

Adjust the output level.

22: 2VOICE-PITCH-SHIFTER

A Pitch Shifter shifts the pitch of the original sound. This 2-voice pitch shifter has two pitch shifters, and can add two pitch shifted sounds to the original sound.

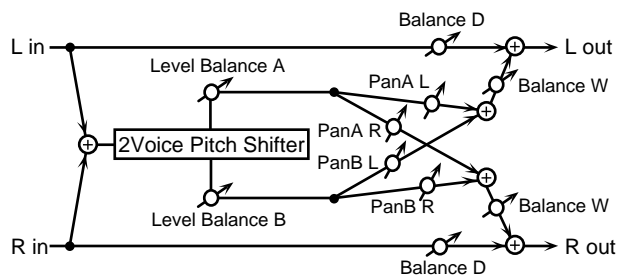

CoarseA (Coarse Pitch A) #1

Adjust the pitch of Pitch Shift A in semitone steps (-2--+1 octaves).

Fine A (Fine Pitch A) #1

Make fine adjustments to the pitch of Pitch Shift A in 2-cent steps (-100--+100 cents).

* One cent is 1/100th of a semitone.

Pan A (Output Pan A)

Adjust the stereo location of the Pitch Shift A sound. L64 is far left, 0 is center, and 63R is far right.

PreDlyA (Pre Delay Time A)

Adjust the time delay from when the direct sound begins until the Pitch Shift A sound is heard.

CoarseB (Coarse Pitch B) #2

Adjust the pitch of Pitch Shift B in semitone steps (-2--+1 octaves).

Fine B (Fine Pitch B) #2

Make fine adjustments to the pitch of Pitch Shift B in 2-cent steps (-100--+100 cents).

* One cent is 1/100th of a semitone.

Pan B (Output Pan B)

Adjust the stereo location of the Pitch Shift B sound. L64 is far left, 0 is center, and 63R is far right.

PreDlyB (Pre Delay Time B)

Adjust the time delay from when the direct sound begins until the Pitch Shift B sound is heard.

Mode (Pitch Shifter Mode)

Higher settings of this parameter will result in slower response, but steadier pitch.

Lvl Bal (Level Balance)

Adjust the volume balance between the Pitch Shift A and Pitch Shift B sounds.

Balance (Effect Balance)

Adjust the volume balance between the direct sound and the pitch shift sound. With a setting of D100:0W only the direct sound will be output, and with a setting of D0:100W only the pitch shift sound will be output.

Level (Output Level)

Adjust the output level.

23: FBK-PITCH-SHIFTER (Feedback Pitch Shifter)

This pitch shifter allows the pitch shifted sound to be fed back into the effect.

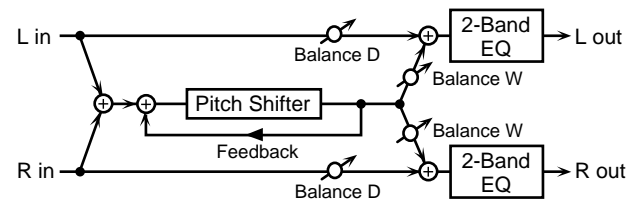

Coarse (Coarse Pitch) #1

Adjust the pitch of the pitch shifted sound in semitone steps (-2--+1 octaves).

Fine (Fine Pitch) #1

Make fine adjustments to the pitch of the pitch shifted sound in 2-cent steps (-100--+100 cents).

* One cent is 1/100th of a semitone.

Fbk (Feedback Level)

Adjust the proportion (%) of the processed sound that is fed back into the effect. Negative (-) settings will invert the phase.

Pre Dly (Pre Delay Time)

Adjust the time delay from when the direct sound begins until the pitch shifted sound is heard.

Mode (Pitch Shifter Mode)

Higher settings of this parameter will result in slower response, but steadier pitch.

Pan (Output Pan)

Adjust the stereo location of the pitch shifted sound. L64 is far left, 0 is center, and 63R is far right.

LowGain

Adjust the gain of the low frequency range.

Hi Gain

Adjust the gain of the high frequency range.

Balance (Effect Balance)

Adjust the volume balance between the direct sound and the pitch shift sound. With a setting of D100:0W only the direct sound will be output, and with a setting of D0:100W only the pitch shift sound will be output.

Level (Output Level)

Adjust the output level.

24: REVERB

The Reverb effect adds reverberation to the sound, simulating an acoustic space.

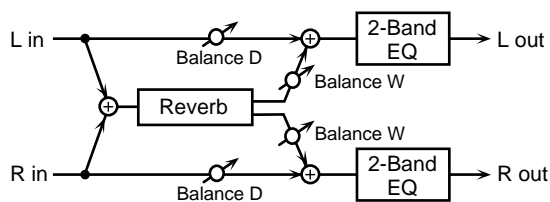

Type (Reverb Type)

Select the type of Reverb effect.

- ROOM1:** dense reverb with short decay
- ROOM2:** sparse reverb with short decay
- STAGE1:** reverb with greater late reverberation
- STAGE2:** reverb with strong early reflections
- HALL1:** reverb with clear reverberance
- HALL2:** reverb with rich reverberance

Pre Dly (Pre Delay Time)

Adjust the time delay from when the direct sound begins until the reverb sound is heard.

Time (Reverb Time) #

Adjust the time length of reverberation.

HF Damp

Adjust the frequency above which the reverberant sound will be cut. As the frequency is set lower, more of the high frequencies will be cut, resulting in a softer and more muted reverberance. If you do not want the high frequencies to be cut, set this parameter to BYPASS.

LowGain

Adjust the gain of the low frequency range.

Hi Gain

Adjust the gain of the high frequency range.

Balance (Effect Balance) #

Adjust the volume balance between the direct sound and the reverb sound. With a setting of D100:0W only the direct sound will be output, and with a setting of D0:100W only the reverb sound will be output.

Level (Output Level)

Adjust the output level.

25: GATE-REVERB

Gate Reverb is a special type of reverb in which the reverberant sound is cut off before its natural length.

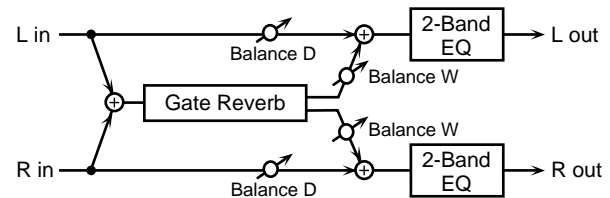

Type (Gate Reverb Type)

Select the type of reverb.

- NORMAL:** conventional gate reverb
- REVERSE:** backwards reverb
- SWEEP1:** the reverberant sound moves from right to left
- SWEEP2:** the reverberant sound moves from left to right

Pre Dly (Pre Delay Time)

Adjust the time delay from when the direct sound begins until the reverb sound is heard.

Gate Time

Adjust the time from when the reverb is heard until when it disappears.

LowGain

Adjust the gain of the low frequency range.

Hi Gain

Adjust the gain of the high frequency range.

Balance (Effect Balance) #

Adjust the volume balance between the direct sound and the reverb sound. With a setting of D100:0W only the direct sound will be output, and with a setting of D0:100W only the reverb sound will be output.

Level (Output Level) #

Adjust the output level.

26: OVERDRIVE→CHORUS

This effect connects an overdrive and a chorus in series.

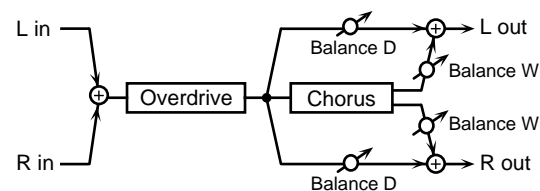

OD Drive

Adjust the degree of overdrive distortion. The volume will change together with the degree of distortion.

OD Pan (Overdrive Pan) #

Adjust the stereo location of the overdrive sound. L64 is far left, 0 is center, and 63R is far right.

Cho Dly (Chorus Pre Delay Time)

Adjust the time delay from when the direct sound begins until the chorus sound is heard.

ChoRate (Chorus Rate)

Adjust the modulation speed of the chorus effect.

Chorus Depth

Adjust the modulation depth of the chorus effect.

Chorus Balance

Adjust the volume balance between the overdrive sound that is sent through the chorus and the overdrive sound that is not sent through the chorus. With a setting of "D100: 0W," only the overdrive sound will be output. With a setting of "D0: 100W," only the overdrive sound that is sent through the chorus will be output.

Level (Output Level)

Adjust the output level.

27: OVERDRIVE→FLANGER

This effect connects an overdrive and a flanger in series.

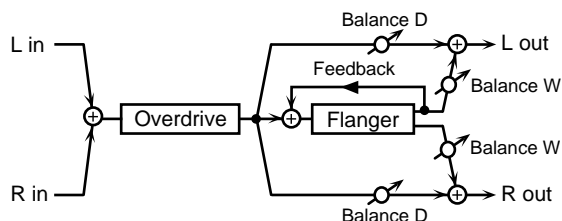

OD Drive

Adjust the degree of overdrive distortion. The volume will change together with the degree of distortion.

OD Pan (Overdrive Pan)

Adjust the stereo location of the overdrive sound. L64 is far left, 0 is center, and 63R is far right.

Flg Dly (Flanger Pre Delay Time)

Adjust the time delay from when the direct sound begins until the flanger sound is heard.

FlgRate (Flanger Rate)

Adjust the modulation speed of the flanger effect.

Flg Dpt (Flanger Depth)

Adjust the modulation depth of the flanger effect.

Flg Fbk (Flanger Feedback Level)

Adjust the proportion (%) of the flanger sound that is fed back into the effect. Negative (-) settings will invert the phase.

Flanger Balance

Adjust the volume balance between the overdrive sound that is sent through the flanger and the overdrive sound that is not sent through the flanger. With a setting of "D100: 0W," only the overdrive sound will be output. With a setting of "D0: 100W," only the overdrive sound that is sent through the flanger will be output.

Level (Output Level)

Adjust the output level.

28: OVERDRIVE→DELAY

This effect connects an overdrive and a delay in series.

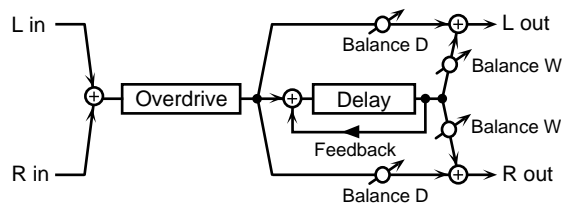

OD Drive

Adjust the degree of overdrive distortion. The volume will change together with the degree of distortion.

OD Pan (Overdrive Pan)

Adjust the stereo location of the overdrive sound. L64 is far left, 0 is center, and 63R is far right.

DlyTime (Delay Time)

Adjust the time delay from when the direct sound begins until the delay sound is heard.

Dly Fbk (Delay Feedback Level)

Adjust the proportion (%) of the delay sound that is fed back into the effect. Negative (-) settings will invert the phase.

Delay HF Damp

Adjust the frequency above which delayed sound fed back to the effect will be cut. If you do not want to cut the high frequencies of the feedback, set this parameter to BYPASS.

Delay Balance (Delay Balance)

Adjust the volume balance between the overdrive sound that is sent through the delay and the overdrive sound that is not sent through the delay. With a setting of "D100: 0W," only the overdrive sound will be output. With a setting of "D0: 100W," only the overdrive sound that is sent through the delay will be output.

Level (Output Level)

Adjust the output level.

29: DISTORTION→CHORUS

This effect connects distortion and chorus in series. The parameters are essentially the same as "26: OVERDRIVE→CHORUS," with the exception of the following two.

OD Drive → Dist Drive (Specify the amount of distortion.)

OD Pan → Dist Pan (Specify the stereo location of the distortion sound.)

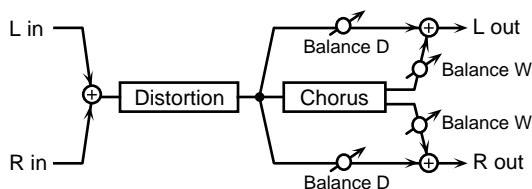

30: DISTORTION → FLANGER

This effect connects distortion and flanger in series. The parameters are essentially the same as in “27: OVERDRIVE → FLANGER,” with the exception of the following two.

- OD Drive → Dist Drive (Specify the amount of distortion.)
- OD Pan → Dist Pan (Specify the stereo location of the distortion sound.)

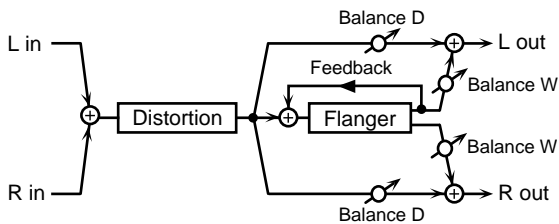

31: DISTORTION → DELAY

This effect connects distortion and delay in series. The parameters are essentially the same as in “28: OVERDRIVE → DELAY,” with the exception of the following two.

- OD Drive → Dist Drive (Specify the amount of distortion.)
- OD Pan → Dist Pan (Specify the stereo location of the distortion sound.)

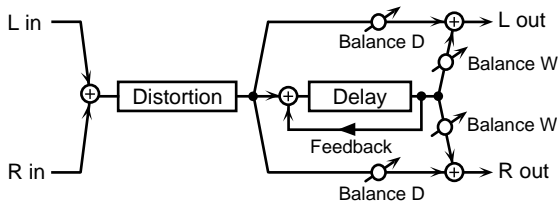

32: ENHANCER → CHORUS

This effect connects an enhancer and a chorus in series.

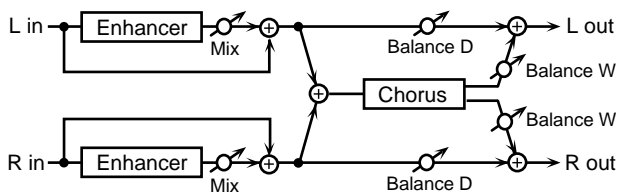

Enhancer Sens

Adjust the sensitivity of the enhancer.

Enhancer Mix (Enhancer Mix Level)

Adjust the ratio with which the overtones generated by the enhancer are combined with the direct sound.

Cho Dly (Chorus Pre Delay Time)

Adjust the time delay from when the direct sound begins until the chorus sound is heard.

ChoRate (Chorus Rate)

Adjust the modulation speed of the chorus effect.

Chorus Depth

Adjust the modulation depth of the chorus effect.

Chorus Balance

Adjust the volume balance between the enhancer sound that is sent through the chorus and the enhancer sound that is not sent through the chorus. With a setting of “D100: 0W,” only the enhancer sound will be output. With a setting of “D0: 100W,” only the enhancer sound that is sent through the chorus will be output.

Level (Output Level)

Adjust the output level.

33: ENHANCER → FLANGER

This effect connects an enhancer and a flanger in series.

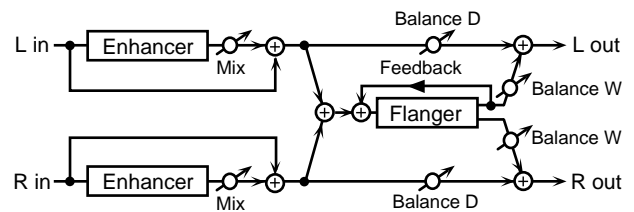

Enhancer Sens

Adjust the sensitivity of the enhancer.

Enhancer Mix (Enhancer Mix Level)

Adjust the ratio with which the overtones generated by the enhancer are combined with the direct sound.

Flg Dly (Flanger Pre Delay Time)

Adjust the time delay from when the direct sound begins until the flanger sound is heard.

FlgRate (Flanger Rate)

Adjust the modulation speed of the flanger effect.

Flg Dpt (Flanger Depth)

Adjust the modulation depth of the flanger effect.

Flg Fbk (Flanger Feedback Level)

Adjust the proportion (%) of the flanger sound that is fed back into the effect. Negative (-) settings will invert the phase.

Flanger Balance

Adjust the volume balance between the enhancer sound that is sent through the flanger and the enhancer sound that is not sent through the flanger. With a setting of “D100: 0W,” only the enhancer sound will be output. With a setting of “D0: 100W,” only the enhancer sound that is sent through the flanger will be output.

Level (Output Level)

Adjust the output level.

34: ENHANCER→DELAY

This effect connects an enhancer and a delay in series.

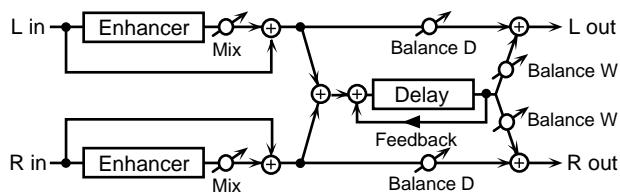

Enhancer Sens

Adjust the sensitivity of the enhancer.

Enhancer Mix (Enhancer Mix Level)

Adjust the ratio with which the overtones generated by the enhancer are combined with the direct sound.

DlyTime (Delay Time)

Adjust the time delay from when the direct sound begins until the delay sound is heard.

Dly Fbk (Delay Feedback Level)

Adjust the proportion (%) of the delay sound that is fed back into the delay input. Negative (-) settings will invert the phase.

Delay HF Damp

Adjust the frequency above which delayed sound fed back to the delay input will be cut. If you do not want to cut the high frequencies of the delay feedback, set this parameter to BYPASS.

Delay Balance

Adjust the volume balance between the enhancer sound that is sent through the delay and the enhancer sound that is not sent through the delay. With a setting of "D100: 0W," only the enhancer sound will be output. With a setting of "D0: 100W," only the enhancer sound that is sent through the delay will be output.

Level (Output Level)

Adjust the output level.

35: CHORUS→DELAY

This effect connects a chorus and a delay unit in series.

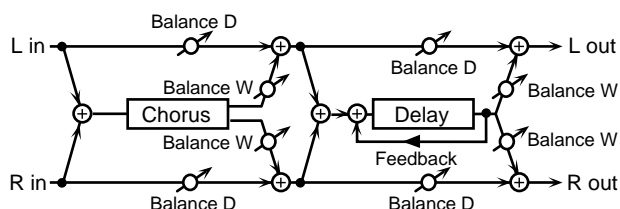

Cho Dly (Chorus Pre Delay Time)

Adjust the time delay from when the direct sound begins until the chorus sound is heard.

ChoRate (Chorus Rate)

Adjust the modulation speed of the chorus effect.

Cho Dpt (Chorus Depth)

Adjust the modulation depth of the chorus effect.

Cho Bal (Chorus Balance)

Adjust the volume balance between the direct sound and the chorus sound. With a setting of "D100: 0W," only the direct sound will be output. With a setting of "D0: 100W," only the chorus sound will be output.

DlyTime (Delay Time)

Adjust the time delay from when the direct sound begins until the delay sound is heard.

Dly Fbk (Delay Feedback Level)

Adjust the proportion (%) of the delay sound that is fed back into the delay input. Negative (-) settings will invert the phase.

Delay HF Damp

Adjust the frequency above which delayed sound fed back to the delay input will be cut. If you do not want to cut the high frequencies of the feedback, set this parameter to BYPASS.

Delay Balance

Adjust the volume balance between the chorus sound that is sent through the delay and the chorus sound that is not sent through the delay. With a setting of "D100: 0W," only the chorus sound will be output. With a setting of "D0: 100W," only the chorus sound that is sent through the delay will be output.

Level (Output Level)

Adjust the output level.

36: FLANGER→DELAY

This effect connects a flanger and a delay in series.

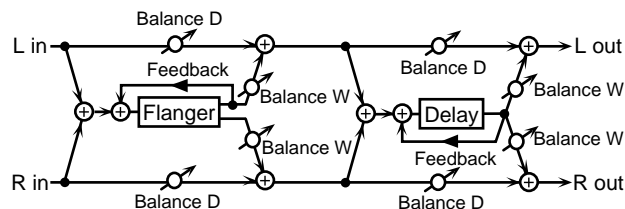

Flg Dly (Flanger Pre Delay Time)

Adjust the time delay from when the direct sound begins until the flanger sound is heard.

FlgRate (Flanger Rate)

Adjust the modulation speed of the flanger effect.

Flg Dpt (Flanger Depth)

Adjust the modulation depth of the flanger effect.

Flg Fbk (Flanger Feedback Level)

Adjust the proportion (%) of the flanger sound that is fed back into the effect. Negative (-) settings will invert the phase.

Flg Bal (Flanger Balance)

Adjust the volume balance between the direct sound and the flanger sound. With a setting of "D100: 0W," only the direct sound will be output. With a setting of "D0: 100W," only the flanger sound will be output.

DlyTime (Delay Time)

Adjust the time delay from when the direct sound begins until the delay sound is heard.

Dly Fbk (Delay Feedback Level)

Adjust the proportion (%) of the delay sound that is fed back into the delay input. Negative (-) settings will invert the phase.

HF Damp

Adjust the frequency above which delayed sound fed back to the delay input will be cut. If you do not want to cut the high frequencies of the delay feedback, set this parameter to BYPASS.

Delay Balance #

Adjust the volume balance between the flanger sound that is sent through the delay and the flanger sound that is not sent through the delay. With a setting of "D100: 0W," only the flanger sound will be output. With a setting of "D0: 100W," only the flanger sound that is sent through the delay will be output.

Level (Output Level)

Adjust the output level.

37: CHORUS→FLANGER

This effect connects a chorus and a flanger in series.

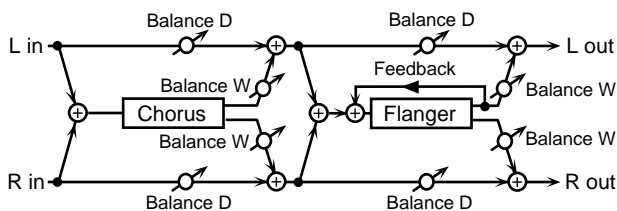

Cho Dly (Chorus Pre Delay Time)

Adjust the time delay from when the direct sound begins until the chorus sound is heard.

ChoRate (Chorus Rate)

Adjust the modulation speed of the chorus effect.

Cho Dpt (Chorus Depth)

Adjust the modulation depth of the chorus effect.

Cho Bal (Chorus Balance) #

Adjust the volume balance between the direct sound and the chorus sound. With a setting of "D100: 0W," only the direct sound will be output. With a setting of "D0: 100W," only the chorus sound will be output.

Flg Dly (Flanger Pre Delay Time)

Adjust the time delay from when the direct sound begins until the flanger sound is heard.

FlgRate (Flanger Rate)

Adjust the modulation speed of the flanger effect.

Flg Dpt (Flanger Depth)

Adjust the modulation depth of the flanger effect.

Flg Fbk (Flanger Feedback Level)

Adjust the proportion (%) of the flanger sound that is fed back into the effect. Negative (-) settings will invert the phase.

Flanger Balance #

Adjust the volume balance between the chorus sound and the chorus sound that is passed through the flanger. With a setting of "D100: 0W," only the chorus sound will be output. With a setting of "D0: 100W," only the chorus sound that passes through the flanger will be output.

Level (Output Level)

Adjust the output level.

38: CHORUS/DELAY

This effect connects a chorus and a delay in parallel. The parameters are the same as for "35: CHORUS→DELAY." However, the Delay Balance parameter adjusts the volume balance between the direct sound and the delay sound.

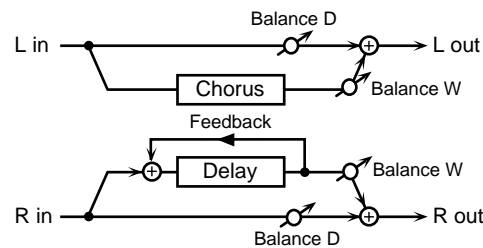

39: FLANGER/DELAY

This effect connects a flanger and a delay in parallel. The parameters are the same as for "36: FLANGER→DELAY." However, the Delay Balance parameter adjusts the volume balance between the direct sound and the delay sound.

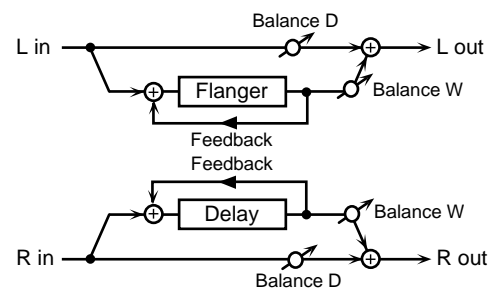

40: CHORUS/FLANGER

This effect connects a chorus and a flanger in parallel. The parameters are the same as for "37: CHORUS→FLANGER." However, the Flanger Balance parameter adjusts the volume balance between the direct sound and the flanger sound.

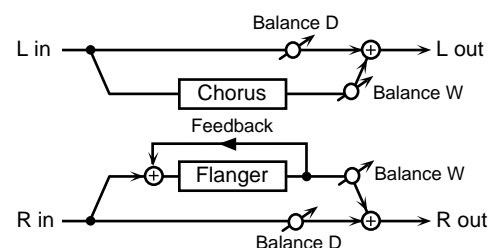

XP-30 Operating Environment Setup (System Parameters and Their Functions)

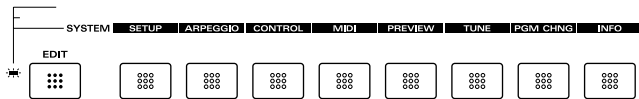

■ Display Screen Contrast and Clock Settings (SETUP)

SYSTEM SETUP

LCD Contrast

Adjust the contrast (brightness) of the display.

Power Up Mode

Select the condition that the XP-30 will be in when the power is turned on.

LAST-SET: The XP-30 will be in the condition it was in when power was last turned off.

DEFAULT: The XP-30 will be ready to play Patch "USER:001."

Patch Remain (Patch Remain Switch)

If you want currently-sounding notes to be turned off when a new Patch (Rhythm Set) is selected, set this parameter OFF.

* *Effects settings change as soon as you switch to a new Patch or Rhythm Set, without being influenced by the Patch Remain setting. Because of this, certain effects settings can cause notes that were until then sounding to no longer be heard, even though Patch Remain has been set to on.*

Clock Source

Specify the tempo clock of the system.

INT: The internal clock will be the tempo clock for the system.

MIDI: An external clock will be the tempo clock for the system.

System Tempo

Set the system tempo.

* *When Clock Source is set to MIDI, the tempo will synchronize to the clock messages received from an external MIDI device, so it will not be possible to set the tempo value. The tempo of the external clock will be displayed in parentheses.*

Category Select Mode

When searching for patches, specify the patch that will be selected when you press the numeric key.

LAST-SET: The patch last-selected during the previous patch search will be selected.

DEFAULT: The patch specified as the factory default will be selected.

■ Arpeggio Settings (ARPEGGIO)

This is where to set Arpeggiator parameters.

ARPEGGIO

Style

Sets the style of the arpeggio. Select from the following 43 options. For creating your own style, choose LIMITLESS.

1/4: The rhythm will be divided in quarter notes.

1/6: The rhythm will be divided in quarter note triplets.

1/8: The rhythm will be divided in eighth notes.

1/12: The rhythm will be divided in eighth note triplets.

1/16: The rhythm will be divided in 16th notes.

1/32: The rhythm will be divided in 32nd notes.

PORTAMENTO A, B: A style using the portamento effect.

GLISSANDO: A glissando style.

SEQUENCE A–D: Styles for sequenced patterns.

ECHO: An echo-like style.

SYNTH BASS, SLAP BASS A, SLAP BASS B, WALK BASS: Styles appropriate for bass playing.

RHYTHM GTR A–E: Styles for guitar cutting. Styles B–E are effective when 3–4 notes are held.

3 FINGER GTR: Three-finger guitar style.

STRUMMING GTR: A style simulating a guitar chord strummed upward (downward). Effective when 5–6 notes are held.

KBD COMPING A, B: Styles for keyboard instrument backing.

KBD COMPING C, D: Styles in triple meter.

KBD COMPING E: A reggae-type style. Effective when 3 notes are held.

PERCUSSION: A style suitable for percussive instrument sounds.

HARP: The playing style of a harp.

SHAMISEN: The playing style of a Shamisen.

BOUND BALL: A style suggestive of a bouncing ball.

RANDOM: A style in which the notes sound in random order.

BOSSANOVA: A style with bossanova guitar cutting. Hold 3–4 notes for best results. You can increase the tempo and use this as a Samba.

SALSA: Typical salsa style. Hold 3–4 notes for best results.

MAMBO: Typical mambo style. Hold 3–4 notes for best results.

LATIN PERCUSSION: A rhythm style with Latin percussion instruments such as Clave, Cowbell, Clap, Bongo, Conga, Agogo etc.

SAMBA: Typical samba style. Use for rhythm patterns or bass lines.

TANGO: Typical tango rhythm style. Hold the root, 3rd and 5th of a triad etc. for best results.

HOUSE: A style for house piano backing. Hold 3–4 notes for best results.

LIMITLESS: The settings of all parameters can be freely combined without restriction.

* Choices can be set for the Motif, Beat Pattern, Shuffle Rate and Accent Rate parameters for each style. Refer to the “Arpeggio Style List” (p. 182).

Octave Range

Sets the key range in octaves over which arpeggio will take place. If you want the arpeggio to sound using only the notes that you actually play, set this parameter to 0. To have the arpeggio sound using the notes you play and notes 1 octave higher, set this parameter to +1. A setting of -1 will make the arpeggio sound using the notes you play and notes 1 octave lower.

Motif

Sets the order in which notes of the chord will sound. Some settings will not be available depending on the Style parameter setting.

- SINGLE UP:** Notes will sound singly, starting from the lowest key pressed.
- SINGLE DOWN:** Notes will sound singly, starting from the highest key pressed.
- SINGLE UP&DOWN:** Notes will sound singly, starting from the lowest key pressed, going up and then back down.
- SINGLE RANDOM:** Notes will sound singly in random order.
- DUAL UP:** Notes will sound in pairs, starting from the lowest key pressed.
- DUAL DOWN:** Notes will sound in pairs, starting from the highest key pressed.
- DUAL UP&DOWN:** Notes will sound in pairs, starting from the lowest key pressed, going up and then back down.
- DUAL RANDOM:** Notes will sound in pairs, in random order.
- TRIPLE UP:** Notes you press will sound three at a time, from low to high.
- TRIPLE DOWN:** Notes you press will sound three at a time, from high to low.
- TRIPLE UP&DOWN:** Notes you press will sound three at a time, from low to high and then back down from high to low.
- TRIPLE RANDOM:** Notes you press will sound three at a time, in random order.
- NOTE ORDER:** Notes will sound in the order that they were pressed. Up to 32 notes can be stored, so you can create melody lines by pressing keys in the appropriate order.

GLISSANDO: Notes will be played in an ascending and descending chromatic scale between the lowest and the highest keys that are pressed. Simply press two notes, the lowest and highest.

CHORD: All notes that are pressed will sound simultaneously.

BASS+CHORD1-5: The lowest note that is pressed and other notes will sound as a chord.

BASS+UP1-8: The lowest note that is pressed and other notes will sound as an arpeggio.

BASS+RANDOM1-3: The lowest note that is pressed and other notes will sound randomly.

TOP+UP1-6: The highest note that is pressed and other notes will sound as an arpeggio.

BASS+UP+TOP: Simulated fingering of folk guitar’s three-finger picking technique.

Beat Pattern

Select the beat pattern from the choices below. This setting will affect the location of the accent and length of the notes to determine the beat (rhythm).

Some settings will not be available depending on the Style parameter setting.

1/4, 1/6, 1/8, 1/12, 1/16 1-3, 1/32 1-3, PORTA-A 01-11, PORTA-B 01-15, SEQ-A 1-7, SEQ-B 1-5, SEQ-C 1-2, SEQ-D 1-8, ECHO 1-3, MUTE 01-16, STRUM1-8, REGGAE1-2, REFRAIN1-2, PERC1-4, WALKBS, HARP, BOUND, RANDOM, BOSSA NOVA, SALSA 1-4, MAMBO 1-2, CLAVE, REV CLA, GUIRO, AGOGO, SAMBA, TANGO 1-4, HOUSE 1-2

Accent Rate

Modifies the strength of accents and the length of the notes to adjust the “groove” feel of the arpeggio. A setting of 100% will produce the most pronounced groove feel.

Shuffle Rate

This parameter allows you to modify the timing of an up-beat between two down-notes next to each other, to create shuffle rhythms. With a setting of 50%, the notes will be spaced evenly. Higher values will give more of a “dotted” (shuffle) feel.

Key Velocity

Sets the force of the chord. If you wish to use the velocity at which the notes are actually played, set this parameter to REAL. To use a constant velocity regardless of the force with which you play the keyboard, choose a desired value from 1-127.

Part (Arpeggio Part)

When using a Layer performance, you can use this parameter to specify the Part for playing an arpeggio. Parts other than that you specify will sound as you play on the keyboard.

* *This setting will be invalid if Single performance, Patch mode or Rhythm Set mode is selected.*

Tempo

Sets the speed of the arpeggio. This setting is the same as the tempo of the song. Changing this setting will also affect the song's playback tempo.

When the Clock Source parameter (SYSTEM/SETUP/ SYSTEM SETUP) is set to INT, the display will indicate Tempo(=SYS), and this will be the same value as the system tempo. With a setting of MIDI, the display will indicate Tempo(=EXT), and you will be synchronized to the clock of the external MIDI device.

Keyboard and Controllers Settings (CONTROL)

KEYBOARD

Transpose (Transpose Switch/Value)

If you wish to transpose the range of the keyboard, turn this switch ON and set the desired amount of transposition (in semitone steps). Tonic is indicated in parentheses ().

* *The transposed note name will be shown in the lower right of the Performance/Patch/Rhythm Set play display.*

* *When transposing the keyboard range, press [TRANSCOPE] and indicator lights.*

* *To change transpose amount on a PLAY display, hold down [TRANSCOPE] and press [-OCT] or [+OCT].*

Sens (Keyboard Sensitivity)

Select the keyboard sensitivity.

LIGHT: light

MEDIUM: normal

HEAVY: heavy

Vel (Keyboard Velocity)

Specify the velocity value that will be transmitted when you play the keyboard. If you want the actual keyboard velocity to be transmitted, set this to REAL. If you want a fixed velocity value to be transmitted regardless of how you play, specify the desired value.

Aft (Aftertouch Sensitivity)

Specify the Aftertouch sensitivity. Higher values will allow Aftertouch to be applied more easily. Normally you should leave this set to 100.

HOLD PEDAL

Set the function of the pedal connected to the HOLD PEDAL jack.

Output (Pedal Output)

Select the sound source(s) (the internal sound source and/or external sound sources connected to MIDI OUT connector) which will be controlled by the pedal.

OFF: Neither will be controlled.

INT: Only the internal sound source will be controlled.

MIDI: Only external sound sources will be controlled.

BOTH: Both the internal sound source and external sound sources will be controlled.

Polarity (Pedal Polarity)

This parameter switches the polarity of the Hold pedal. On some pedals, the electrical signal output by the pedal when it is pressed or released is the opposite of other pedals. If your pedal has an effect opposite of what you expect, set this parameter to **REVERSE**. If you are using a Roland pedal (that has no polarity switch), set this parameter to **STANDARD**.

CONTROL PEDAL

Assign the function of the pedals connected to the CONTROL PEDAL jack.

Assign (Pedal Assign)

Select the function controlled by the pedal.

CC01–95: Controller numbers 1–95 (except for 6, 32–63).

PITCH BEND: Pitch bend

AFTERTOUCH: Aftertouch

PROG-UP: Every press of the pedal selects the next Performance number, Patch number, or Rhythm Set.

PROG-DOWN: Every press of the pedal selects the previous Performance number, Patch number, or Rhythm Set.

TAP-TEMPO: Tap tempo (a tempo specified by the interval at which you press the pedal).

OCT-UP: Each pedal press raises the key range in octave steps (up to 3 octaves higher).

OCT-DOWN: Each pedal press lowers the key range in octave steps (up to 3 octaves lower).

Output (Pedal Output)

Select the sound source(s) (the internal sound source and/or external sound sources connected to MIDI OUT connector) which will be controlled by the pedals.

OFF: Neither will be controlled.

INT: Only the internal sound source will be controlled.

MIDI: Only external sound sources will be controlled.

BOTH: Both the internal sound source and external sound sources will be controlled.

Polarity (Pedal Polarity)

This parameter switches the polarity of the pedals. On some pedals, the electrical signal output by the pedal when it is pressed or released is the opposite of other pedals. If your pedal has an effect opposite of what you expect, set this parameter to **REVERSE**. If you are using a Roland pedal (that has no polarity switch), set this parameter to **STANDARD**.

C1/C2/C3/C4 ASSIGN (C1/C2/C3/C4 Slider Assign)

These parameters set the functions controlled by the C1–C4 sliders.

Assign (C1/C2/C3/C4 Slider Assign)

Select the function controlled by each slider.

CC01–95: Controller numbers 1–95 (except for 6, 32–63).

PITCH BEND: Pitch bend

AFTERTOUCH: Aftertouch

* *Depending on the functions being controlled, the value may remain unchanged when the slider is moved, even if the Patch or Performance is switched.*

Output (C1/C2/C3/C4 Slider Output)

Select the sound source(s) (the internal sound source and/or external sound sources connected to MIDI OUT connector) which will be controlled by the sliders.

OFF: Neither will be controlled.

INT: Only the internal sound source will be controlled.

MIDI: Only external sound sources will be controlled.

BOTH: Both the internal sound source and external sound sources will be controlled.

SYS-CTRL ASSIGN (System Control Assign)**Control 1/2 (System Control Assign 1/2)**

These settings allow you to choose two controllers for common use when controlling the parameters of a Patch or Performance. The settings in each Patch (or Performance) will determine whether the two controllers you choose here will actually be used. You will also need to specify for each Patch (or Performance) the parameters that will be controlled.

CC01–95: Controller numbers 1–95 (except for 6, 32–63).

PITCH BEND: Pitch bend

AFTERTOUCH: Aftertouch

* *To use the selected controllers, you need to make System settings and Patch/Performance settings so that the MIDI messages transmitted by the selected controllers will be received.*

* *For many control change messages, the function performed by each number is defined in the MIDI specification. These settings allow you to use control change messages without regard to their officially defined function, so please be aware of what you are doing.*

CONTROL SOURCE

Select the type of MIDI message that will be used to control each of the following functions.

Hold (Hold Control Source)

Select the type of pedal message that will be used to hold the current parameter values.

OFF: not used

HOLD1: Hold 1 (controller number 64)

SOST: Sostenuato (controller number 66)

SOFT: Soft pedal (controller number 67)

HOLD2: Hold 2 (controller number 69)

Peak (Peak Control Source)

Select the type of pedal message that will be used to hold the highest received parameter values.

OFF: not used

HOLD1: Hold 1 (controller number 64)

SOST: Sostenuato (controller number 66)

SOFT: Soft pedal (controller number 67)

HOLD2: Hold 2 (controller number 69)

Volume (Volume Control Source)

Specify whether or not Expression messages (controller number 11) will affect the volume of a Patch or Part as well as Volume messages (controller number 7).

VOLUME: Only Volume messages and not Expression messages will affect the volume.

VOL&EXP: Both Volume messages and Expression messages will affect the volume.

Aftertouch (Aftertouch Control Source)

Specify the type(s) of aftertouch message that will affect the internal sound source.

CHANNEL: Channel pressure

(the aftertouch that applies equally to all keys)

POLY: Polyphonic key pressure (the aftertouch that applies independently to each key)

CH&POLY: Channel pressure and Polyphonic key pressure

* *The XP-30's keyboard is not able to transmit Polyphonic Key Pressure messages.*

■ MIDI Settings (MIDI)

These parameters determine MIDI channel settings and how exclusive data is handled.

- * *The first display of the MIDI group will be different depending on the mode you were in when you pressed [SYSTEM] (Patch mode/Performance mode/GM mode).*

PERFORM MIDI (Performance MIDI)

Make MIDI settings for Performance mode. To make these settings, press [SYSTEM] when you are in Performance mode, and then press [MIDI] located in the row of function buttons.

Control Channel (Performance Control Channel)

Select the receive channel used for selecting Performances via MIDI (Program Change and Bank Select messages). If you do not wish to use MIDI messages to select Performances, turn this OFF. If you set this to the same channel as the receive channel of a Part, Performance selection will take priority and it will not be possible to select Patches on that Part via MIDI.

- * *The MIDI Receive Channel of each Part is set independently for each Performance.*

Local (Local Switch)

Specify whether or not the controller section will be connected to the internal sound source (all Parts). Normally you will leave this ON, but if you wish to use the XP-30's keyboard and controllers to control only external sound sources, turn this OFF.

- * *If you want the keyboard controller section to be disconnected only from a specific Part or Parts, use the Local parameter (PERFORM/MIDI/MIDI).*

Remote (Remote Keyboard Switch)

Turn this parameter on when you want to use an external MIDI keyboard in place of the XP-30's keyboard. In this case, the transmit channel of the external MIDI keyboard can be set to any channel. Normally you will leave this parameter off.

- * *Set this parameter ON if you want performance using the Arpeggiator to be controlled by an external MIDI device.*
- * *When the Remote keyboard switch is on, all messages that arrive at MIDI IN are output from MIDI OUT.*

PATCH MIDI

Make MIDI settings for Patch mode. To make these settings, press [SYSTEM] when you are in Patch mode, and then press [MIDI] located in the row of function buttons.

Rx-Ch (Patch Mode Receive Channel)

Select the channel on which MIDI messages will be received in Patch mode.

Tx-Ch (Patch Mode Transmit Channel)

This parameter selects the transmit channel for MIDI messages in Patch mode. If you do not want to transmit MIDI messages to external MIDI devices, turn this parameter off. If you want the transmit channel to always match the Patch Mode Receive Channel, set this parameter to Rx-Ch.

Local (Local Switch)

Specify whether or not the controller section will be connected to the internal sound source (all Parts). Normally you will leave this ON, but if you wish to use the XP-30's keyboard and controllers to control only external sound sources, turn this OFF.

Remote (Remote Keyboard Switch)

Turn this parameter on when you want to use an external MIDI keyboard in place of the XP-30's keyboard. In this case, the transmit channel of the external MIDI keyboard can be set to any channel. Normally you will leave this parameter off.

GM MIDI

Make MIDI settings for GM mode. To make these settings, press [SYSTEM] when you are in GM mode, and then press [MIDI] located in the row of function buttons.

Local (Local Switch)

Specify whether or not the controller section will be connected to the internal sound source (all Parts). Normally you will leave this ON, but if you wish to use the XP-30's keyboard and controllers to control only external sound sources, turn this OFF.

RECEIVE MIDI

Select whether or not to receive MIDI messages to select Patches, Rhythm Sets, or Performances.

Program Change (Receive Program Change Switch)

If you want Program Change messages to be received, turn this ON. If not, turn it OFF.

Bank Select (Receive Bank Select Switch)

If you want Bank Select messages to be received, turn this ON. If not, turn it OFF.

TRANSMIT MIDI

Specify how MIDI messages will be transmitted.

Program (Transmit Program Change Switch)

If you want Program Change messages to be transmitted, turn this ON. If not, turn it OFF.

Bank Sel (Transmit Bank Select Switch)

If you want Bank Select messages to be transmitted, turn this ON. If not, turn it OFF.

Active Sensing (Transmit Active Sensing Switch)

If you want Active Sensing messages to be transmitted, turn this ON. If not, turn it OFF.

SYS-EXC MIDI (Exclusive MIDI)

Specify how Exclusive messages will be transmitted and received.

Device# (Exclusive Device ID Number)

When you want to transmit or receive Exclusive messages, set this parameter to match the Device ID number of the other MIDI device.

Rx.Exc (Receive Exclusive Switch)

If you want Exclusive messages to be received, turn this ON. If not, turn it OFF.

Tx.Edit (Transmit Edit Data Switch)

If you want Exclusive messages to be transmitted for each change you make while editing a Patch, Performance, or Rhythm Set, turn this ON. If not, turn it OFF.

Rx.GM (Receive GM Exclusive Switch)

If you want GM-related Exclusive messages to be received, turn this ON. If not, turn it OFF.

* For details on the GM MIDI messages, refer to “**Chapter 5. Using the XP-30 as the GM Sound Module**” (p. 124).

BANK-SEL GROUP (Bank Select Group)

Each Performance has a Bank Select Group setting (PERFORM/MIDI/TRANSMIT). The Bank Select Group parameter of each Performance specifies how Bank Select messages are transmitted when the Performance is selected. Here, you can specify the actual Bank Select Number that is transmitted for each of the BS1–7 selections that were made in Performance mode.

Number (Bank Select Group Number)

Select the Bank select group you wish to set. The contents of each BS number are determined by the following settings for Switch, MSB and LSB.

Switch (Bank Select Transmit Switch)

If you want the selected Bank select group to transmit its assigned Bank Select number, turn this ON. If you do not want the selected BS number to transmit a Bank Select message, turn this OFF.

MSB (Bank Select MSB)

Specify the MSB of the Bank Select number transmitted by the selected BS number.

LSB (Bank Select LSB)

Specify the LSB of the Bank Select number transmitted by the selected BS number.

Phrase Preview Settings (PREVIEW)

Specify how the phrase will play when you press [PHRASE PREVIEW].

PREVIEW MODE**Mode (Preview Sound Mode)**

SINGLE: The notes specified by Note 1–4 will sound successively one by one.

CHORD: The notes specified by Note 1–4 will sound simultaneously.

PHRASE: The phrase prepared for the Patch type (category) will sound.

PREVIEW KEY**Note 1–4 (Preview Note Set 1–4)**

Specify the pitch (C-1–G9) of the four notes that will sound when Mode (Preview Sound Mode) is set to either SINGLE or CHORD.

* If PHRASE is selected for Mode, these settings will have no effect.

PREVIEW VELOCITY

Specify the velocity (0–127) of the four notes that will sound when Mode (Preview Sound Mode) is set to either SINGLE or CHORD.

* If PHRASE is selected for Mode, these settings will have no effect.

Adjusting Tuning (TUNE)

Parameters in this group adjust the tuning of the internal sound source, or change the temperament of the keyboard.

* The SCALE display of TUNE group will be different depending on the mode you were in when you pressed [SYSTEM].

TUNE**Master (Master Tune)**

This parameter tunes the internal sound source. The displayed value indicates the pitch (frequency) of the A4 key.

Key Shift

Adjust the pitch of the internal sound source in semitone steps.

Scale Tune (Scale Tune Switch)

Turn this ON when you wish to play a scale other than equal temperament. You can specify one scale for Patch mode and one scale for Performance mode/GM mode. To set the tuning of each note in the scale, use the following SCALE display.

* The selected scale is used even for MIDI messages received from an external MIDI device.

PATCH SCALE KEY SCALE

If you wish to define a scale for use in Patch mode, press [SYSTEM] while in Patch mode, and then press [TUNE] located in the row of function buttons. to access the PATCH SCALE display. If you wish to define a scale for use in Performance mode/GM mode, press [SYSTEM] while in Performance mode, and then press [TUNE] located in the row of function buttons to access the KEY SCALE display. To make settings for another Part, use the cursor buttons to select the desired Part. Define a scale by specifying how much the pitch will differ from the equal tempered pitch (in steps of 1 cent). In Patch mode there are separate screens for the white keys and black keys, and the settings for one octave (C–G) will determine the tuning for all octaves. In Performance mode/GM mode, you can make settings for each key in each Part.

* One cent is 1/100th of a semitone.

Equal Temperament

This scale divides an octave into 12 equal parts for the tuning system that is most widely used in Western music. The XP-30 employs equal temperament when the Scale Tune Switch is set OFF.

Pure Temperament (Tonic is C)

With this tuning, the three fundamental chords sound richer compared to equal temperament. This effect only applies to one key, and transposition makes the chord ambiguous.

Arabian Scale

In this scale, E and B are a quarter-note lower and C#, F# and G# are quarter-note higher compared to equal temperament. The intervals between G and B, C and E, F and G#, A# and C#, and D# and F# have a natural third (the interval between a major third and a minor third). With the XP-30, you can play Arabian scale in G, C and F keys.

<Examples>

Note name	Equal temperament	Pure temperament (tonic C)	Arabian scale
C	0	0	-6
C#	0	-8	+45
D	0	+4	-2
Eb	0	+16	-12
E	0	-14	-51
F	0	-2	-8
F#	0	-10	+43
G	0	+2	-4
G#	0	+14	+47
A	0	-16	0
Bb	0	+14	-10
B	0	-12	-49

Program Change (PGM CHNG)

TRANSMIT P.C (Transmit Program Change)

When you want to transmit MIDI messages (Program Change and Bank Select) to select sounds on an external MIDI device, make settings in this display and then press the ENTER button.

Channel (Transmit MIDI Channel)

Select the channel on which the MIDI message will be transmitted.

P.C# (Transmit Program Change)

Select the Program Number you wish to transmit.

Bnk-MSB (Transmit Bank Select MSB)

Select the MSB (control number 0) of the Bank Select number you wish to transmit.

Bnk-LSB (Transmit Bank Select LSB)

Select the LSB (control number 32) of the Bank Select number you wish to transmit.

Checking Things Such as the Installation Status of Wave Expansion Boards (INFO)

INFO EXP (Information Expansion Board)

The names of Wave Expansion Boards installed in slots EXP-D and E are displayed. Slots without any boards installed are indicated “-----.”

* If for both Expansion D: and Expansion E: an identically named Wave Expansion Board is displayed, it will be possible to select data only from the Wave Expansion Board installed in the EXP-D slot. Also, the XP-30 already contains the data of the three Wave Expansion Boards listed below, and if the names of any of these Wave Expansion Boards are displayed, it will be possible to select only the onboard data (XP-A–C).

- SR-JV80-09 “Session” (XP-A)
- SR-JV80-02 “Orchestral” (XP-B)
- SR-JV80-11 “Techno Collection” (XP-C)

BATTERY CHECK

The XP-30 contains a battery that backs up the data in internal memory. This display allows you to check the battery voltage. If the display indicates OK, there is sufficient battery voltage. If the display indicates LOW, the battery voltage has run down. Contact your nearby Roland service station to have the battery replaced.

Chapter 4. Memory Settings (Utility/Card Mode)

The Utility mode allows you to store Patch/Performance/Rhythm Set settings (Write), and transmit data (Data Transfer), as well as other global XP-30 memory settings.

About Utility/Card Mode

The XP-30 goes into Utility/Card mode if you press [UTIL/CARD]. The indicator will blink. Utility/Card mode offers nine functions categorized into two groups—UTIL 1 and UTIL 2.

UTIL 1 (Utility 1)

```
UTIL 1:WRITE | 2: COPY | 3: INIT | 4: XFER | 5: PRO-  
1↓ | | | | | TECT
```

WRITE

This function writes Patch, Performance or Rhythm Set settings you've modified into user memory (p. 116).

COPY

This function copies data from a Patch, Performance or Rhythm Set into the current Patch, Performance or Rhythm Set (p. 117).

INIT (Initialize)

This resets parameters of the current Patch, Performance or Rhythm Set to default factory settings (p. 119).

XFER (Data Transfer)

This function transmits Patch, Performance, Rhythm Set or System settings to an external MIDI device (p. 119).

PROTECT (User Memory Protect)

This function prevents user memory from being accidentally rewritten (p. 121).

UTIL 2 (Utility 2)

```
UTIL 1: CARD | 2: LOAD | 3: SAVE | 4: FACTORY  
2↓ | | | | RESET
```

CARD

Here you can make settings related to memory cards (p. 121).

LOAD

This function loads data from memory card into the XP-30's memory (p. 122).

SAVE

This function saves data to memory card (p. 122).

FACTORY RESET

This function resets all the settings stored in the XP-30 to the factory default settings (p. 123).

Basic Procedure in Utility/Card Mode

* In order to use a memory card, you must first turn off the power, and then insert a memory card into the card slot.

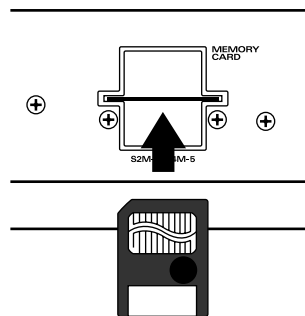

1. Press [UTIL/CARD] so its indicator blinks. The XP-30 will switch to Utility/Card mode.

```
UTIL 1:WRITE | 2: COPY | 3: INIT | 4: XFER | 5: PRO-  
1↓ | | | | TECT
```

* The type of data that will be written, copied and initialize depends on the mode you are in when you press [UTIL/CARD].

2. Press [▲] or [▼] to select the group (UTIL 1, UTIL 2) containing the function you want.

3. Use [◀] or [▶] to select the desired function (the function name will blink), and press [ENTER]. The display of the function you've selected will appear.

* You can also access the desired function display by using the numeric keys or function buttons to specify the number of the function.

* If you selected the UTIL 2 group function "1: CARD," the CARD display will appear. Here you can once again select the desired function.

4. Set parameters as necessary on each function's display.

* To cancel the operation, press [EXIT].

5. Press [ENTER] to execute the function.

When the operation is completed, the display will briefly indicate "COMPLETED."

6. To return to the UTIL 1 or UTIL 2 displays, press [EXIT]. To return to the display of the previous mode, press [UTIL/CARD] to make the indicator go dark.

Storing Sound Data in User Memory (WRITE)

If you turn the power off or select another Patch, Performance, or Rhythm Set after you have modified a Patch, Performance, or Rhythm Set settings, the modified data will be lost. If you wish to keep the data, store it into user memory.

Internal Write Protect

An **Internal Write Protect** setting is provided to prevent the settings in user memory from being overwritten accidentally. When rewriting user memory settings, you need to turn off Internal Write Protect. If you attempt to write data when Internal Write Protect is on, the following display will appear.

```
WRITE █ Number █ [COMPARE]
PROTECT █ Internal Write Protect= ON
```

Change the displayed ON to OFF and press [ENTER] to turn Internal Write Protect off. Press [ENTER] once again, and the data will be written into user memory. Once you turn Internal Write Protect off, it will remain off until the XP-30's power is turned off.

■ Performance Write

The settings of the current Performance will be written into user memory. Press [UTIL/CARD] in Performance mode, and perform Write operation.

```
PERFORM █ Number █ [CENTER]
WRITE █ User: 01(EasternSplit)
```

Writing destination Performance (group, number, name)

* *By holding down [SHIFT] and pressing [UTIL/CARD], you can move directly to the PERFORM WRITE display.*

■ Patch Write

The settings of the current Patch will be written into user memory. Press [UTIL/CARD] in Patch mode, then perform Write operation.

```
PATCH █ Number █ [COMPARE]/[CENTER]
WRITE █ User:001(Temple of XP)
```

Writing destination Patch (group, number, name)

* *By holding down [SHIFT] and pressing [UTIL/CARD], you can move directly to the PATCH WRITE display.*

The Compare Function

The Compare function allows you to play the Patch currently occupying the writing destination, so that you can check whether you really want to overwrite it. To play the Patch of the writing destination, press [UNDO/COMPARE] to access the PATCH COMPARE display. You can select the writing destination Patch in this display as well. After selecting the writing destination Patch, press [EXIT] to return to the previous display.

```
PATCH █ Number █ [COMPARE]
COMPARE █ User:001(Temple of XP)
```

Writing destination Patch (group, number, name)

* *Please be aware that when the Compare function is used to play a Patch, it may sound slightly different than when it is played normally.*

■ Rhythm Set Write

The settings of the current Rhythm Set will be written into user memory. Press [UTIL/CARD] in Rhythm Set mode, then perform Write operation.

```
RHYTHM █ Number █ [COMPARE]/[CENTER]
WRITE █ User:002(JazzDrumSet1)
```

Writing destination Rhythm Set (group, number, name)

* *By holding down [SHIFT] and pressing [UTIL/CARD], you can move directly to the RHYTHM WRITE display.*

The Compare Function

The Compare function allows you to play the Rhythm Set currently occupying the writing destination, so that you can check whether you really want to overwrite it. To play the Rhythm Set of the writing destination, press [UNDO/COMPARE] to access the RHYTHM COMPARE display. You can select the writing destination Rhythm Set in this display as well. After selecting the writing destination Rhythm Set, press [EXIT] to return to the previous display.

```
RHYTHM █ Number █ [COMPARE]
COMPARE █ User:002(JazzDrumSet1)
```

Writing destination Rhythm Set (group, number, name)

* *Please be aware that when the Compare function is used to play a Rhythm Set, it may sound slightly different than when it is played normally.*

Copying Sound Source Settings (COPY)

This function lets you copy data of any Patch, Performance, or Rhythm Set into the current Patch, Performance, or Rhythm Set. Using this function effectively makes editing easier.

■ Performance Copy

To copy the settings of a Performance, press [UTIL/CARD] in Performance mode, then perform Copy operation.

Performance Part Copy

The Part settings of a Performance will be copied to the Part you specify of the current Performance.

```
PERFORM █ Source|Part [ENTER]
PART CPV █USER: 01|P 1(EasternSplit) → P 1
```

Copy source Performance (group, number) Copy source Performance name
 Copy source Part Copy destination Part

- * To specify the currently selected Performance as the copy source, set Source to TEMP.
- * When the Copy operation is executed, an "*" will be displayed in front of the copy-destination part name.

Performance Effects Copy

The effects settings of a Performance or Patch will be copied to the current Performance.

```
PERFORM █ Source|Number
FX COPY █ PERFORM|USER: 01(EasternSplit)
```

Copy source Copy source Patch/Performance (group, number, name)

Press [▶] to move to the next display, and then select the contents of the effect that you wish to copy.

```
PERFORM █Type [ENTER]
FX COPY █ALL
```

Copy type

- ALL:** Multi-effects, chorus, and reverb settings
- EFX:** Multi-effects settings
- CHORUS:** Chorus settings
- REVERB:** Reverb settings
- CHO&REV:** Chorus and reverb settings

Performance Name Copy

The name of a Performance will be copied to the current Performance.

```
PERFORM █Number [ENTER]
NAME CPV █USER: 01(EasternSplit)
```

Copy source Performance (group, number, name)

■ Patch Copy

When you want to copy Patch settings to the current Patch, press [UTIL/CARD] in Patch mode and perform Copy operation.

Patch Tone Copy

Tone settings of a Patch will be copied to the Tone you specify of the current Patch.

```
PATCH █ Source|Tone [COMPARE]/[ENTER]
TONE CPV █USER:001|T1(Temple of XP) → T1
```

Copy source Patch (group, number) Copy source Patch name
 Copy source Tone Copy destination Tone

- * To specify the currently selected Patch as the copy source, set Source to TEMP.
- * When the Copy operation is executed, an "*" will be displayed in front of the copy-destination tone.

Patch Effects Copy

The effects settings of a Patch or Performance will be copied to the current Patch.

```
PATCH █ Source|Number
FX COPY █ PATCH|USER:001(Temple of XP)
```

Copy source Copy source Patch/Performance (group, number, name)

Press [▶] to move to the next display, and then select the contents of the effect that you wish to copy.

```
PATCH █Type [COMPARE]/[ENTER]
FX COPY █ALL
```

Copy type

- ALL:** Multi-effects, chorus, and reverb settings
- EFX:** Multi-effects settings
- CHORUS:** Chorus settings
- REVERB:** Reverb settings
- CHO&REV:** Chorus and reverb settings

The Compare Function

For the Patch Tone Copy and Patch Effect Copy operations, you can use the Compare function. The Compare function allows you to play the Patch currently occupying the copy source. To play the Patch of the copy source, press [UNDO/COMPARE] to access the PATCH COMPARE display. The copy-source Patch can be changed in this display as well, but it is not possible to select patches from XP-A-E. After selecting the copy source Patch, press [EXIT] to return to the previous display.

```
PATCH  #Number [COMPARE]
COMPARE #User:001(Temple of XP)
```

Copy source Patch (group, number, name)

- * The Compare function cannot be used with Patch Tone Copy if either TEMP or an XP-A-E patch is selected as the copy source patch (Source).
- * The Compare function cannot be used with Patch Effect Copy if PERFORM is selected as the copy source (Source).
- * Please be aware that when the Compare function is used to play a Patch, it may sound slightly different than when it is played normally.

Patch Name Copy

The name of a Patch will be copied to the current Patch.

```
PATCH  #Number [ENTER]
NAME CPY #User:001(Temple of XP)
```

Copy source Patch (group, number, name)

Rhythm Set Copy

When you want to copy Rhythm Set settings to the current Rhythm Set, press [UTIL/CARD] in Rhythm Set mode and perform Copy operation.

Rhythm Key Copy

Individual key settings in a Rhythm Set will be copied to each key in the current Rhythm Set.

```
RHYTHM #Source|Key [COMPARE]/[ENTER]
KEY COPY #USER:001|B 1(HouseDrumSet)+ B 1
```

Copy source Rhythm Set
(group, number)

Copy source
Rhythm Set name

Copy source Key Copy destination Key

- * The copy source and copy destination Key parameters can also be set by pressing a key on the keyboard.
- * When the Copy operation is executed, an "*" will be displayed in front of the copy-destination key.

The Compare Function

The Compare function can be used during the Rhythm Key Copy operation.

The Compare function allows you to play the Rhythm Set currently occupying the copy source. To play the Rhythm Set of the copy source, press [UNDO/COMPARE] to access the RHYTHM COMPARE display. The copy-source Rhythm Set can be changed in this display as well, but it is not possible to select patches from XP-A-E. After selecting the copy source Rhythm Set, press [EXIT] to return to the previous display.

```
RHYTHM #Number [COMPARE]
COMPARE #User:002(JazzDrumSet1)
```

Copy source Rhythm Set (group, number, name)

- * If one of the XP-A-E Rhythm Sets is selected as the copy-source Rhythm Set (Source), the Compare function is not available.
- * Please be aware that when the Compare function is used to play a Rhythm Set, it may sound slightly different than when it is played normally.

Rhythm Set Name Copy

The name of a Rhythm Set will be copied to the current Rhythm Set.

```
RHYTHM #Number [ENTER]
NAME CPY #USER:001(HouseDrumSet)
```

Copy source Rhythm Set (group, number, name)

Initializing Sound Source Settings (INIT)

This function resets settings of the current Patch, Performance, or Rhythm Set to a standard value or to factory default settings.

* Only current data will be initialized, and data resident in user memory will not be rewritten. To reset all settings to factory defaults, execute Factory Reset (UTILITY/UTIL 2/FACTORY RESET).

Data can be initialized in two ways depending on the application.

Mode (Initialize Mode)

DEFAULT: Resets current data to the standard values called “Initial data” (INIT PATCH, INIT PERFORM or INIT SET). This mode is selected when creating sound from scratches.

PRESET: Resets the current data in user memory to the factory settings.

* If the current data is a Patch, Performance or Rhythm Set in preset memory (PR-A–PR-C, E, GM), and initialization is performed with PRESET specified, the data will be reset to the value of the correspondingly numbered user memory.

Performance Initialize

To initialize Performance settings, press [UTIL/CARD] in Performance mode and execute initialization.

```
PERFORM | Mode | [ENTER]
INIT | DEFAULT |
```

Patch Initialize

To initialize Patch settings, press [UTIL/CARD] in Patch mode and execute initialization.

```
PATCH | Mode | [ENTER]
INIT | DEFAULT |
```

Rhythm Set Initialize

To initialize Rhythm Set settings, press [UTIL/CARD] in Rhythm Set mode and execute initialization.

The Rhythm Set Initialize operation can also be used to initialize the settings of only an individual percussion instrument sound (key) that you specify. In this case, move the cursor to Key, and select the percussion instrument sound that you wish to initialize. You can specify the percussion instrument sound either from the keyboard, or by pressing TONE SELECT [1]–[4].

```
RHYTHM | Mode | Key | [ENTER]
KEY INIT | DEFAULT | B 1
```

```
RHYTHM | Mode | [ENTER]
INIT | DEFAULT |
```

Transmitting Sound Settings (XFER)

This function lets you transmit sound source or System settings that are in the XP-30’s memory or stored on memory card to an external MIDI device or User memory.

Transmitting Data to an External MIDI Device

The process of transmitting Patch, Performance, Rhythm Set or System data to an external MIDI device is called **Bulk dump**. This process is used when two XP-30s with the same Patch, Performance and/or Rhythm Set settings are connected for performance or when recording Patch, Performance, Rhythm Set or System data into an external MIDI device as a backup for accidental data deletion.

```
TRANSFER | Type | Block | [ENTER]
TO MIDI | ALL | USER | →MIDI
```

Data type | Source block | Destination

While data is being transmitted, the following display will appear.

```
TRANSFER | Executing... | [ENTER]
TO MIDI | PERFORM | USER: 01 | →MIDI
```

* To cancel data transmission, press [EXIT].

* If you expect to successfully use settings that stipulate the use of XP-A/B/C waves and patches after they’ve been sent to another unit (XP-50/60/80; or JV-1010/1080/2080), you first need to make sure that the relevant Wave Expansion Boards are installed in the other unit.

Chapter 4. Memory Settings (Utility/Card Mode)

Specifies the data to be transmitted through the combinations as shown below.

For example, if you wish to transmit the USER group Patches 001–020, you would specify “PATCH USER:001-020.”

Type	Block		
ALL	USER		
	TEMP		
PERFORM	USER	01–32	
	TEMP	-PATCH	*1
		+PATCH	*2
	CTRL		
PATCH	USER	001–128	
	TEMP		
RHYTHM	USER	001–002	
	TEMP		
SYSTEM	USER		

*1 The current Performance

*2 The current Performance and the Patch or Rhythm Set assigned to each Part of the Performance

Type (Data Type)

Specify the type of data to be transmitted.

ALL: Performance, Patch, and Rhythm Set

PERFORM: Performance

PATCH: Patch

RHYTHM: Rhythm Set

SYSTEM: System

Block (Source Block)

Specify the source of the data to be transmitted.

USER: Transmit the data from user memory.

TEMP: Transmit the data from the temporary area.

CTRL: Transmit messages for Performance bank select, Performance program change, and Volume and Pan messages for the Parts whose Rx parameter (PERFORM/MIDI/MIDI) is turned ON.

Destination

Set the transmission destination to MIDI.

■ Transmitting Data to User Memory

You can transmit Patch, Performance or Rhythm Set settings to the user memory and System settings to the system memory. By loading sound data from memory card or Wave Expansion Boards to user memory, you can add many different sounds to your performance.

TRANSFER↑	Type Block	[ENTER]
TO USER ↓	ALL PR-A	→User
	└──┬──┘	
	Data type Source block	Destination

Specifies the data to be transmitted through the combinations as shown below.

For example if you wish to transmit only the PR-A group Patch 001, specify “PATCH PR-A:001-001”

* If the specified data will not fit completely into the transmission destination, as much of the data as will fit will be transmitted, starting at the first number of the specified transmission destination.

(Example)

Block PATCH PR-A:001—005

Destination User:127

If the above settings are made and transmission is executed, only the two PR-A group Patches 01 and 02 will be transmitted to USER group Patches 127 and 128.

Type	Block		
ALL	PR-A		
	PR-B		
PERFORM	USER	01–32	
	PR-A, B	01–32	
	CARD	**	*1
PATCH	USER	001–128	
	PR-A–C, GM, PR-E	001–128	
	XP-A, B	001–255	
	XP-C	001–256	
	XP-D, E	001–***	*2
	CARD	**	*1
RHYTHM	USER	001–002	
	PR-A–C, GM, PR-E	001–002	
	XP-A, C	001–008	
	XP-D, E	001–***	*2
	CARD	**	*1
SYSTEM	Card	**	*1

*1 Specified by file number

*2 Depends on the Wave Expansion Board installed

Type (Data Type)

Specify the type of data to be transmitted.

ALL: Performance, Patch, and Rhythm Set

PERFORM: Performance

PATCH: Patch

RHYTHM: Rhythm Set

SYSTEM: System (other than sequencer section)

■ Formatting the Memory Card for the XP-30 (FORMAT)

This function initializes (formats) a memory card so that XP-30 data can be saved to it. Before a new memory card or a memory card used on another device can be used on the XP-30, it must be formatted on the XP-30.

* Please be aware that formatting will erase all the data already resident on the memory card.

```
CARD [ENTER]
FORMAT [ENTER]
```

■ Renaming a File (RENAME)

This function changes the name of a file on the memory card.

* A file name of up to eight characters can be assigned. For details on assigning a name, refer to “Assigning a Name” (p. 46).

* File name extensions cannot be changed.

```
Original file name
RENAME 01: SOUND_00.SVD [ENTER]
        [SOUND_00] [SHIFT]
New file name
```

■ Deleting Unwanted Files (DELETE)

Use this function to delete unwanted files from memory card.

```
DELETE 01: SOUND_00.SVD [ENTER]
```

■ Checking the Contents Memory Card (INFO)

This function displays the number of files on the memory card, the free area of the disk, and the size of each file.

```
File number  File name  File size
CARD 01: SOUND_00.SVD 64KB
INFO 1files 3846KB free
Number of files on memory card  Free area
```

Loading a File from Memory Card into the XP-30 (LOAD)

A data file containing Patch, Performance, Rhythm Set settings and System settings will be loaded into internal memory.

* Loading a new file will rewrite data currently resident in memory. To keep existing data, save it to memory card before loading new data.

```
LOAD 01: SOUND_00.SVD [ENTER]
```

* If you wish to load only a portion of data from the file, refer to “Transmitting Data to User Memory” (p. 120).

Saving Data to Memory Card (SAVE)

The Patch, Performance, Rhythm Set, and System settings in internal memory will be saved as a single file to memory card, with the name you specify.

To overwrite a previously existing file on the memory card, select the file number of that file.

```
SAVE 00: [SOUND_00].SVD [ENTER]
```

* Data files contain an entire set of parameter settings for the sound source. It is not possible to save individual Patches or Performances to memory card.

* A file name of up to eight characters can be assigned. For details on assigning a name, refer to “Assigning a Name” (p. 46).

The number of files that can be saved will depend on the memory card you use.

S2M-5 (2MB type): approximately 29 files

S4M-5 (4MB type): approximately 59 files

Recalling Factory Default Settings (FACTORY RESET)

This operation will restore all the data in the XP-30 to the factory settings.

* *If the XP-30 internal memory already contains important data that you have created, this operation will cause all of this data to be lost. If you wish to keep the data, you must save it on an optional memory card (p. 122) or on an external MIDI sequencer (p. 119).*

```
FACTORY  | [ENTER]
RESET    |
```

* *If Internal Write Protect is turned ON, the following display will appear, and the Factory Reset operation will not be executed.*

```
WRITE    | Internal Write Protect= ON
PROTECT  |
```

Change the displayed ON to OFF and press [ENTER] to turn Internal Write Protect off.

“Are You Sure?” will be displayed, press [ENTER].

Chapter 5. Using the XP-30 as the GM Sound Module

The XP-30 features a **GM mode**—a convenient way to play back or create GM score data (music files for GM sound module). You're able to play back commercial GM score data releases and even modify various parameter settings for enhanced musical expression.

Entering GM Mode

Use GM mode to place the XP-30's sound source in GM System compatible mode. Basically GM mode is similar to a special kind of Performance in which a GM System Rhythm Set is assigned to Part 10, and GM System Patches are assigned to other Parts. But however, you can't store GM mode settings in user memory.

	GM Patch/Rhythm Set (number, group)	Part number
GM PLAY	GM:001 Piano 1	part= 1 center=C 4

The GM PLAY display shows a Patch or Rhythm Set assigned to each Part. Each time you enter GM mode, the GM Drum Set is assigned to Part 10, and Piano 1 is assigned to other Parts. You can also select other GM Patches and GM Drum Sets for each Part to match the performance.

1. Hold down [SHIFT] and press [PERFORM] to call up the GM PLAY display.

When you switch the XP-30 into GM mode, the sound source initializes itself for basic GM System settings.

2. To change the current Part, press [◀] or [▶].
3. To change the GM Patch or GM Rhythm Set assigned to the Part, perform the same procedure as you do when you select a Patch or Rhythm Set.

■ Initializing the Sound Source for GM System Basic Settings

To play back a GM score correctly, the sound source must first be initialized to basic GM system settings. The XP-30's sound source is initialized in the following situations:

- When the XP-30 is switched to GM mode
- When it receives a GM System On message from an external MIDI device
- When a GM System On message is encountered in the song data being played back

At power on

- When you execute the GM Initialize function (p. 128).
- * Because effects settings are not defined in the GM System, they will not initialize to factory settings unless the GM Initialize (DEFAULT) or Factory Reset is executed.

GM System On Message

The GM System On message puts the unit in a state that conforms to the GM System and initializes a GM-compatible sound module.

- * If the Rx GM parameter (SYSTEM/MIDI/SYS-EXC MIDI) is set OFF, GM System On messages cannot be received.

■ Playing Back a GM Score

When the XP-30 is in GM mode, it plays back GM scores correctly. But beyond this, the XP-30 provides many extended features not defined in GM System specifications, and if you create music files using these extended features, your song may not play back correctly on other GM-compatible sound modules.

- * The XP-30 is not compatible with the GS format (standard format for multitimbral sound sources advocated by Roland). Music files bearing the GS logo (GS music data) may therefore not play back correctly on the XP-30.
- * The beginning of a GM score normally contains a GM System On message. So if you play back a GM score starting in the top of a song, XP-30 will switch itself to GM mode. But if you play back a GM score starting in the middle of a song, XP-30 may not switch itself to GM mode, and the GM score may not play back correctly. So to be safe, it's recommended to manually set the XP-30 to GM mode before playing back a GM score.

Muting a Specific Part

When you switch over to GM mode, all Parts will be set to receive MIDI messages. To turn off a specific Part so that it will not sound, set the Recieve Switch to OFF for the Part.

1. Make sure that [EDIT] indicator is dark. If it is lit, press [EDIT] to turn it off.

At this time, the function button indicators will indicate the on/off status of each Part. When [1-8/9-16] indicator is dark, the function button indicators will indicate the status of Parts 1-8. When [1-8/9-16] indicator is lit, the function button indicators will indicate the status of Parts 9-16. Lit is on, and dark is off.

2. Press the function button to switch Parts on/off.

Modifying GM Mode Settings

GM mode also offers parameters that you can modify for each Part. You can modify settings like effects, pan and level to customize a GM score playback to your preference.

* When GM mode is initialized (p. 128), all these settings will be lost.

1. Hold down [SHIFT] and press [PERFORM] to call up the GM PLAY display.
2. Press [EDIT] to make the indicator light.
3. Use the function buttons to select a display group. The button indicator of the selected display group will blink.

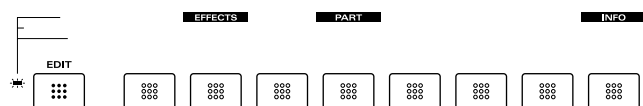

* In GM mode, you can press the function buttons [2/10(EFFECTS)], [4/12(PART)], and [8/16(INFO)].

4. Use [▲] or [▼] to select a display page.
5. If you have selected a parameter display that can be set independently for each Part, the number of the Part selected for editing will be shown in the display. To select a different Part, press [EDIT] to temporarily turn off the indicator, and use [1-8/9-16] and the function buttons to select a Part.
6. Use [◀] or [▶] to move the cursor to the parameter you wish to modify.
7. Use the VALUE dial, [INC]/[DEC] or numeric keys and modify the parameter value.

* If you've made a mistake in setting the parameter value or you don't like the changes, just press [UNDO/COMPARE] to restore the value to what it was.

8. If you wish to move to another display group, press [EDIT] to make the indicator light, and use the function buttons.

* You can also move to another display group by holding down [SHIFT] and using [◀] or [▶]. Since this can be done even when [EDIT] indicator is dark, it is a faster way to get around because you don't have to turn on [EDIT] indicator each time.

9. Repeat steps 3–8 to complete a GM mode settings.
10. When you finish making settings, press [EXIT] to return to the GM PLAY display.

* You can also use the Palette display in the same manner when you edit in Performance mode (p. 65).

■ Making Effects Settings in GM Mode (EFFECTS)

Parameter configurations of GM effects and Performance effects are almost the same. For details refer to “Setting Effects for a Performance (EFFECTS)” (p. 84).

Make settings for the Multi-Effects/Chorus/Reverb effects used in GM mode.

* If an “x” mark is displayed at the right of the display name, the effect for that display has been turned off. Turn the corresponding effect on before you make settings (p. 62).

OUTPUT

Make settings to specify how each Part will be output.

Output Assign (Output Assign/Output Level)

When the Output Assign parameter is set to MIX, the output of each Part will be sent to the OUTPUT jacks without passing through Multi-Effects. If this parameter is set to EFX, the output will be passed through Multi-Effects. If PATCH is selected, the output assign settings of the GM Patch assigned to the Part will be used.

The Output Level parameter adjusts the volume of each Part.

Chorus (Chorus Send Level)

Adjust the amount of chorus for each Part.

Reverb (Reverb Send Level)

Adjust the amount of reverb for each Part.

GM EFX TYPE (EFX Type)

Specify the type of Multi-Effects that will be used in GM mode.

Type (EFX Type)

Select the type of Multi-Effects. For details refer to “Multi-Effects Types (EFX Parameter)” (p. 93).

GM EFX PRM (GM EFX Parameters)

Make parameter settings for the EFX type selected by the Type parameter. For details refer to “Multi-Effects Types (EFX Parameter)” (p. 93).

GM EFX OUT (GM EFX Output)

Specify the output routing for Parts whose Output Assign is set to EFX.

* The settings in this display have no effect on Parts whose Output Assign is set to MIX.

Mix Out (EFX Output Level)

Adjust the volume balance of the direct sound and the Multi-Effects sound.

Chorus (Chorus Send Level)

Adjust the amount of chorus applied to the sound that passed through Multi-Effects.

Reverb (Reverb Send Level)

Adjust the amount of reverb applied to the sound that passed through Multi-Effects.

GM CHORUS

Make settings for the chorus effect used in GM mode.

* In GM mode, the chorus effect settings for the GM Patch assigned to each Part will be ignored (except for the Send Level parameter).

Rate (Chorus Rate)

Adjust the speed of modulation for the chorus sound.

Depth (Chorus Depth)

Adjust the depth of modulation for the chorus sound.

Delay (Chorus Pre Delay)

Adjust the time delay from the original sound until when the chorus sound is heard. Higher settings will create a more spacious sound.

Fbk (Chorus Feedback Level)

Adjust the amount of sound from the chorus that is returned (fed back) to the input of the chorus. Higher settings will result in a more intense effect.

Level (Chorus Level)

Adjust the volume of the chorus sound.

Out (Chorus Output Assign)

Select the way in which the Chorus and Reverb are connected.

MIX: The Chorus sound and the Reverb sound are mixed.

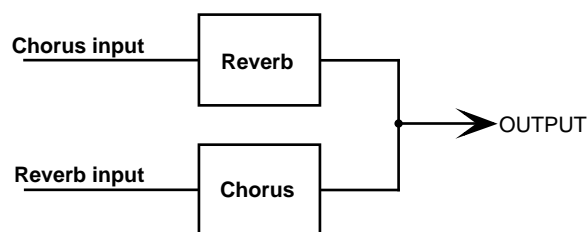

REV: Apply reverb to the chorus sound.

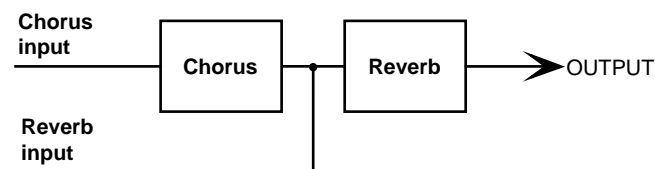

M+R: Mix the chorus sound to which reverb is not applied and the chorus sound to which reverb is applied.

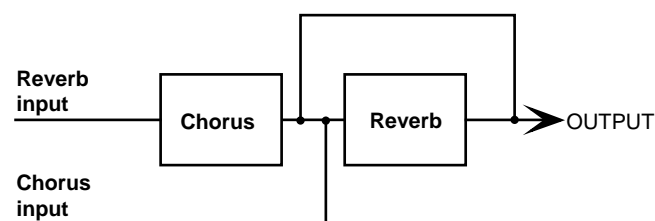

GM REVERB

Make GM mode reverb settings.

* In GM mode, the reverb effect settings for the GM Patch assigned to each Part will be ignored (except for the Send Level parameter).

Type (Reverb/Delay Type)

Select the type of Reverb effect.

ROOM1: dense reverb with short decay

ROOM2: sparse reverb with short decay

STAGE1: reverb with greater late reverberation

STAGE2: reverb with strong early reflections

HALL1: reverb with clear reverberance

HALL2: reverb with rich reverberance

DELAY: a conventional delay

PAN-DLY: a delay with echoes that move left and right

Time (Reverb/Delay Time)

Adjust the time of reverberation. If the Type parameter is set to DELAY or PAN-DLY, this parameter will adjust the time delay from the original sound until when the first echo will sound.

Fbk (Delay Feedback Level)

Adjust the amount of delayed sound that is returned (fed back) to the delay. Higher values result in more delay repeats.

* If you have selected any one of the Reverb types (ROOM1-HALL2), this parameter has no effect.

HF Damp (Reverb/Delay HF Damp)

Adjust the frequency above which the reverberant sound will be cut. As the frequency is set lower, more of the high frequencies will be cut, resulting in a softer and more muted reverberance. If you do not want the high frequencies to be cut, set this parameter to BYPASS.

Level (Reverb/Delay Level)

Adjust the volume of the reverberant (or delayed) sound.

About Effects for GM-Compatible Sound Modules

Most GM-compatible sound sources provide effects such as reverb and chorus, but the use of effects is not included in the GM System Level 1 guidelines. This means that song data created for the XP-30's GM mode that uses Multi-Effects/Reverb/Chorus may not playback correctly on other GM-compatible sound sources.

■ Setting a Part (PART)

PATCH

Select the GM Patch assigned to each Part.

Number (GM Patch Number)

Select the number (001–128) of the GM Patch.

* In GM mode it is not possible to select USER or PRESET A/B/C/E Patches.

SETTING

Make settings for the volume, pan, and pitch of each Part.

Volume

Adjust the volume of each Part.

Pan

Adjust the stereo position of each Part. L64 is full left, 0 is center, and 63R is full right.

* If you modify the settings of the Volume parameter or Pan parameter, they will be reflected in the following INFO group displays.

Coarse (Coarse Tune)

Adjust the pitch of each Part in semitone steps (-4–+4 octaves).

Fine (Fine Tune)

Make fine adjustments in 1-cent steps to the pitch specified in Coarse Tune. (-50–+50 cents)

* 1 cent is 1/100th of a semitone.

■ Confirming MIDI Information of Each Part (INFO)

In this display you can check the receive status of various types of MIDI message for each Part. This is a convenient way to check that the sound source is responding correctly to messages from the keyboard or external MIDI controllers. For items other than Voice, you may modify the values. When you do so, a MIDI message will be transmitted, and can be recorded on the sequencer, etc.

Mod (Modulation Information)

Breath (Breath Information)

Foot (Foot Information)

Vol (Volume Information)

Pan (Pan Information)

Exp (Expression Information)

Hold (Hold 1 Information)

Bend (Pitch Bend Information)

Aftertouch (Aftertouch Information)

Voices (Voice Information)

The number of voices used.

Convenient Functions in GM Mode (GM Utility)

In the GM mode, you can copy effects settings, initialize GM mode, and transmit GM mode settings, using the Utility functions.

Basic Procedure

1. In the GM mode, press [UTIL/CARD] so its indicator blinks.

The XP-30 will switch to Utility/Card mode.

2. Press [▲] or [▼] to select the UTIL 1 group.

```
UTIL 1: 1:-----|2: COPY|3: INIT|4: XFER|5:-----
          1↓
```

* The functions of the UTIL 2 group can also be executed from GM mode. The operation is the same as in other modes.

3. Press [◀] or [▶] to select the desired function (the function name will blink), and press [ENTER].

The display of the function you've selected will appear.

* You can also access the desired function display by using the numeric keys or function buttons to specify the number of the function.

4. Set parameters as necessary on each function's display.

* To cancel the operation, press [EXIT].

5. Press [ENTER] to execute the function.

When the operation is completed, the display will briefly indicate "COMPLETED."

6. To return to the UTIL 1 display, press [EXIT]. To return to the GM PLAY display, press [UTIL/CARD] to make the indicator go dark.

■ Copying Effects Settings (COPY)

This function copies effects settings from a Patch or Performance to the GM mode.

```
GM      Source | Number
FX COPY | PERFORM | USER: 01 (EasternSplit)
```

Copy source Copy source Patch/Performance
(group, number, name)

Press [▶] to move to the next display, and then select the contents of the effect that you wish to copy.

```
GM      Type
FX COPY | ALL [ENTER]
```

Copy type

- ALL:** Multi-effects, chorus, and reverb settings
- EFX:** Multi-effects settings
- CHORUS:** Chorus settings
- REVERB:** Reverb settings
- CHO&REV:** Chorus and reverb settings

■ Initializing GM Mode (INIT)

```
GM      Mode
INIT   | GM-ON [ENTER]
```

* As GM Initialize initializes only GM mode data, data stored in user memory will not be initialized. To initialize all settings to factory settings, use Factory Reset (UTILITY/UTIL 2/FACTORY RESET) (p. 27).

There are two initialize methods.

- GM-ON:** Initializes GM mode settings using a GM System On message.
- DEFAULT:** Initializes all GM mode settings including effects settings to factory settings.

■ Transmitting GM Mode Settings (XFER)

```
TRANSFER | Type | Block [ENTER]
TO MIDI  | GM | Ctrl →MIDI
```

It is not possible to store GM mode settings in user memory. If you wish to keep your GM mode settings, you can transmit them as a MIDI message to an external MIDI device. Prepare the external MIDI device to record data, and press [ENTER].

The following GM mode settings for each Part are transmitted.

- Program number of the GM Patch
- Volume (control number 7)
- Pan (control number 10)
- Reverb send level (control number 91)
- Chorus send level (control number 93)
- Pitch bend sensitivity
- Fine tune
- Coarse tune

* If you do not want the settings of a specific Part to be transmitted, turn off the Receive Switch for that Part (p. 124).

Chapter 6. Getting the Full Potential of the XP-30

This section discusses various techniques for effectively using the XP-30 for specific applications. The more you use the XP-30, the faster you'll appreciate the real power of this unit.

Techniques for Using Patches

■ Reinforcing Filter Characteristics

If you want to reinforce filter characteristics, set the Type parameter (PATCH/COMMON/STRUCT) to 2, and series-connect the TVFs of Tones 1 and 2.

This example shows how to boost the effectiveness of the filter for "PR-C:014 MKS-80 Brass."

1. Select PR-C:014 MKS-80 Brass on the Play display (PATCH).
2. Press [FILTER/ENV] to light the indicator.
3. Move the CUTOFF and RESO. sliders while you play notes and hear how sound changes.
4. Set the Type parameter (PATCH/COMMON/STRUCT) to 2.
5. Again, move the CUTOFF and RESO. sliders and hear how the sound changes.

Notice the effectiveness of the filter has changed.

* If the result is difficult to hear, press [EFFECTS ON/OFF] to turn off each effect unit (Multi-Effects, Chorus, Reverb) (p. 62).

■ Making the Up-Beat Note Sound at the Same Time You Play a Down-Beat Note

1. Select PR-A:087 Music Bells on the PATCH PLAY display and listen to the sound.
2. Call up the TONE DELAY display (PATCH/WAVE).
3. Select Tone 1.
4. Set Tone 1's Mode parameter to PLAYMATE and the Time parameter to 32.
5. Play the XP-30's keyboard keeping a constant tempo. Tones 1 and 2 sound alternately. Tone 1 will sound at the timing point exactly between a note you press and the following note. Try various settings, for instance use different wave or modify the pitch.

* Tone 1 will not sound if the two keys are pressed at an interval of 2 seconds or longer.

■ Holding a Note with Modulation Retained

In general, pressing the Hold pedal makes a note continue to sound. However, other effects will go off. To keep other effects effective as well, perform the following procedure.

1. Connect an optional pedal switch to the HOLD PEDAL jack.
2. Select a Patch (PR-C:110 Crash Pad, etc.) to which an effect will be applied when the modulation lever is moved on the PATCH PLAY display.
3. Set the Hold parameter (SYSTEM/CONTROL/CONTROL SOURCE) to HOLD1.
4. Call up the PEAK & HOLD display (PATCH/CONTROL) and set Ctrl 1 parameter to HOLD.
5. Press a note and press the pedal switch as you move the modulation lever forward.
6. When the note and modulation lever are released, both the note and the effect produced by the modulation lever will be held.

■ Syncing the LFO Cycle to System Tempo

1. Select PR-B:052 Blade Racer on the PATCH PLAY display.
 2. Set the Source parameter (PATCH/COMMON/PATCH CLOCK) to SYSTEM.
 3. Make sure that each Tone's EXTSync parameter (PATCH/LFO/LFO 1, 2) is set to CLOCK. If not, reset.
 4. Set the Clock Source parameter (SYSTEM/SETUP/SYSTEM SETUP) to INT.
- * When the Clock Source parameter is set to MIDI, you can achieve synchronization with the tempo of an external MIDI device.
5. Try playing the keyboard while you change the System Tempo parameter (SYSTEM/SETUP/SYSTEM SETUP) to various values.
 6. Set the modulation depth as desired using LFO DEPTH1:2 display (PATCH/LFO) of each Tone.
- * When you have selected PR-B:047, 049, 051-056, 069, PR-C:034, 093, 097, 099, or 123, it is also possible to synchronize the LFO to the system's tempo clock by setting the Source parameter (PATCH/COMMON/PATCH CLOCK) to SYSTEM. Try it.

■ Modifying Multi-Effects to Match the System's Tempo

1. Select PR-C:094 Albion on the PATCH PLAY display.
2. Set the Source parameter (PATCH/COMMON/PATCH CLOCK) to SYSTEM.
3. Make sure that the Type parameter (PATCH/EFFECTS/PATCH EFX TYPE) is set to STEP-FLANGER. If not, reset.
4. Make sure that the Step Rate parameter (PATCH/EFFECTS/PATCH EFX PRM) is set as a note value. If not, reset using a note value.
5. Set the Clock Source parameter (SYSTEM/SETUP/SYSTEM SETUP) to INT.
6. Try playing the keyboard while you change the System Tempo parameter (SYSTEM/SETUP/SYSTEM SETUP) to various values.

You'll notice that the tempo of the Patch's modulation changes in accordance to the tempo clock of the XP-30's system.

You can modify EFX parameter values in accordance to the system's tempo clock, when you have selected the following types for the EFX Type parameter.

Type	EFX Parameter
16: STEP-FLANGER	Step Rate parameter
19: TRIPLE-TAP-DELAY	Delay L-R parameter
20: QUADRUPLE-TAP-DELAY	Delay 1-4 parameter

* When you have selected PR-B:057, 065, 068, PR-C:094, 096, and 098, it is also possible to sync the EFX parameter variations of the sequencer's tempo clock by setting the Source parameter (PATCH/COMMON/PATCH CLOCK) to SYSTEM. Try it and see.

■ Using a Pedal Switch to Modify the Rotary Speed of the Rotary Effect

1. Call up the CONTROL PEDAL display (SYSTEM/CONTROL) and set the Assign parameter to CC04:FOOT-TYPE.
2. Select PR-A:054 Rocker Spin on the PATCH PLAY display.
This Patch uses ROTARY as the EFX type.
3. Call up the PATCH EFX CTRL display (PATCH/EFFECTS), then set the Speed parameter to FOOT:+63.
4. Connect an optional pedal switch to the CONTROL PEDAL jack.
5. When you wish to speed up the rotary effect, press the pedal switch. Releasing the pedal switch will slow down the rotary effect.

■ Playing Phrase Loops at a System's Tempo

The internal wave expansion XP-C group contains Patches derived from waveforms with tempo (BPM) indication (phrase loops). You can play these phrase loops in sync with the system's tempo.

1. Select XP-C:001 Teknoperator on the PATCH PLAY display.
2. Set the Source parameter (PATCH/COMMON/PATCH CLOCK) to SYSTEM.
3. Call up the WAVE display (PATCH/WAVE).
4. Change the Tone by pressing TONE SELECT [1]-[4] and look for the Tone that uses waveforms with BPM indication.

The wave name will appear in parentheses () below the Number parameter. You'll notice that for this example, Patch Tone 1 uses a phrase loop called 132:Detroit.

5. Call up the TONE DELAY display (PATCH/WAVE).
6. Set the Tone 1's Mode parameter to TEMPO-SYNC.
7. Set the Clock Source parameter (SYSTEM/SETUP/SYSTEM SETUP) to INT.
8. Try playing the keyboard while you change the System Tempo parameter (SYSTEM/SETUP/SYSTEM SETUP) to various values.

The phrase loop speed will change in accordance to the system's tempo clock.

* The phrase loop will sound with the system's tempo regardless of which key you press. The settings for pitch and FXM will be ignored.

■ Using the Slider to Pan Sounds in Real Time

You can assign various functions to the C1 slider. In this example, the stereo location (pan position) of a Patch will change by moving the C1 sliders up or down.

1. Call up the C1 ASSIGN display (SYSTEM/CONTROL).

2. Set the Assign parameter to CC10: PANPOT.

* *With other Assign parameter settings, you can try different variations.*

3. Select a Patch on the PATCH PLAY display.

4. Press [CONTROLLER] to light the indicator.

5. Move the C1 slider while you play the keyboard.

You'll notice that sound will pan right and left.

* *If the stereo location of the sound is difficult to hear, press [EFFECTS ON/OFF] to turn off each effect unit (Multi-Effects, Chorus, Reverb) (p. 62).*

Using the XP-30 to Play Live

■ Changing Multiple Sounds of an External MIDI Device Simultaneously

When a different Performance is selected, the sound corresponding to the Bank Select number and Program number of the selected Performance will usually be chosen on the external MIDI device.

Once you have set the Bank Select number and Program number for each Part to match the desired sound of the external MIDI device, you can select several sounds on the external MIDI device by changing the Performance.

1. Select the Part to be used to control the external MIDI device.

2. Call up the BANK-SEL GROUP display (SYSTEM/MIDI).

3. Set the Number parameter to select the appropriate bank select group to match the bank select of your external MIDI device, turn the Switch parameter ON for that group, and set the LSB and MSB parameters.

4. After switching to the MIDI display (PERFORM/MIDI) for the part that will control the external MIDI device, set the Channel parameter to match the receive channel of the external MIDI device, and turn the Tx parameter ON.

5. Select the TRANSMIT (PERFORM/MIDI) display, and set the Bank Select Group parameter to the bank select group that you selected in step 3.

6. Call up the PATCH display (PERFORM/PART) and set the Number parameter to the same number as the Program number of the sound you wish to play from the external MIDI device.

* *If the Program number of the external MIDI device reads 0–127, set the P.C Number parameter by adding 1 to the external MIDI device's value.*

7. Save the Performance.

8. Try changing from another Performance to the Performance just saved, and see if the sound of the external MIDI device changes to what you want. If not, check your settings and the external MIDI device.

■ Changing Sounds with a Pedal Switch

You can change Patch/Performance/Rhythm Set in succession using a pedal switch.

1. Connect a pedal switch to a CONTROL PEDAL jack.

2. Call up the CONTROL PEDAL display (SYSTEM/CONTROL) and set the Assign parameter to 98:PROG-UP.

3. Call up the PLAY display of a sound source.

4. Each time you press the pedal, you call up the next Patch, Performance or Rhythm Set.

Using External MIDI Devices

■ Using the XP-30 to Control External MIDI Devices

1. Use a MIDI cable to connect the MIDI OUT connector of the XP-30 to the MIDI IN connector of the external MIDI device.

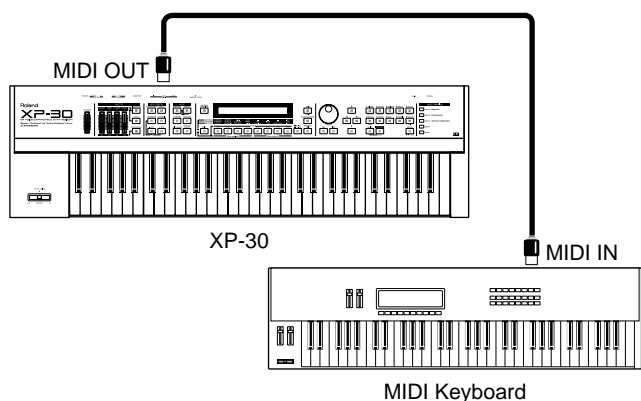

2. Set the XP-30's transmit channel to match the external MIDI device's receive channel.

The transmit channel is determined by the following parameters.

- Patch mode

Tx-Ch parameter (SYSTEM/MIDI/PATCH MIDI)

- Performance mode

Channel parameter (PERFORM/MIDI/MIDI)

Turn the Tx parameter (PERFORM/MIDI/MIDI) to ON.

3. If you want to play only the sound source of the external MIDI device, set the Local parameter (SYSTEM/MIDI/PATCH MIDI) / (SYSTEM/MIDI/PERFORM MIDI) to OFF.

If you wish to connect two or more external MIDI devices, use the MIDI THRU connector of the external MIDI device.

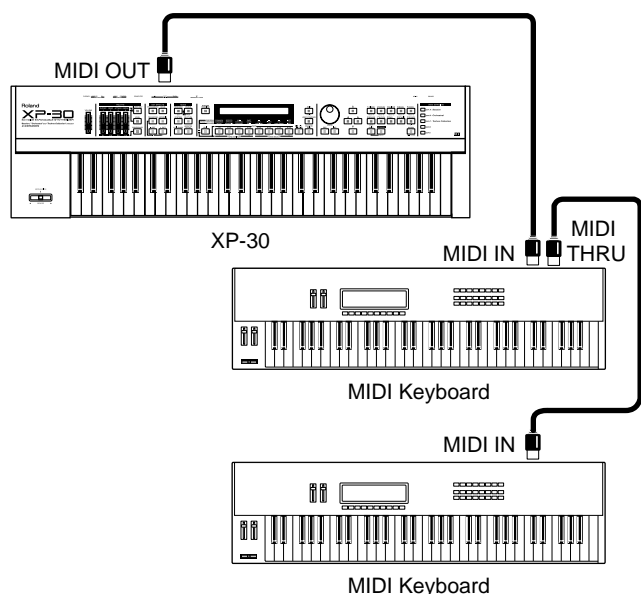

* If you "daisy-chain" three or more MIDI devices using IN → THRU → IN → THRU ..., the MIDI signal may become garbled, and data errors may occur. In such cases, use a MIDI Thru Box. MIDI Thru Boxes are devices that allow a single stream of MIDI data to be sent to a large number of MIDI devices without causing data errors.

■ Playing the XP-30's Sound Source from an External MIDI Device

1. Use a MIDI cable to connect the external MIDI device's MIDI OUT connector to the XP-30's MIDI IN connector.

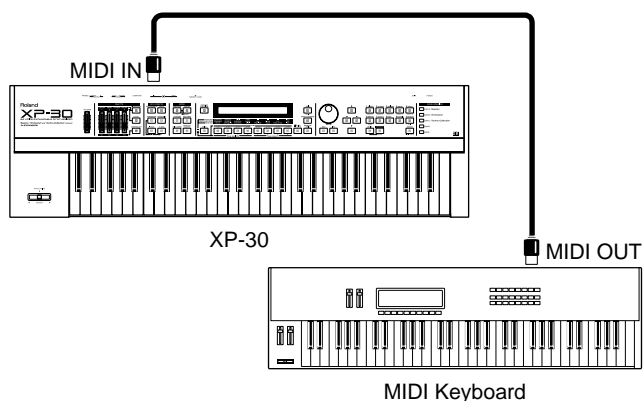

2. Set the XP-30's receive channel to match the external MIDI device's transmit channel.

The receive channel is determined by the following parameters.

- Patch mode

Rx-Ch parameter (SYSTEM/MIDI/PATCH MIDI)

- Performance mode

Channel parameter (PERFORM/MIDI/MIDI)

Turn the Rx parameter (PERFORM/MIDI/MIDI) to ON.

■ Selecting XP-30 Sounds from an External MIDI Device

By transmitting Bank Select messages (controller number 0 and 32) and Program Change messages from the external MIDI device to the XP-30, you can select Patches, Performances, or Rhythm Sets. In other words, when you select sounds on an external MIDI keyboard, the corresponding MIDI message will be transmitted to the XP-30, causing the XP-30 to select the appropriate Patch, etc.

* If the XP-30 receives only Program Change messages without receiving Bank Select messages, it will select sounds only from the currently selected group such as PR-A or USER.

Selecting Patches

The MIDI messages transmitted by the external MIDI device will be received by the XP-30 to select Patches as shown in the following table.

Group	Number	Bank Select		Program Number
		MSB	LSB	
USER	1-128	80	0	1-128
PR-A	1-128	81	0	1-128
PR-B	1-128	81	1	1-128
PR-C	1-128	81	2	1-128
PR-D (GM)	1-128	81	3	1-128
PR-E	1-128	81	4	1-128
XP-A	1-128	84	0	1-128
XP-A	129-255	84	1	1-127
XP-B	1-128	84	2	1-128
XP-B	129-255	84	3	1-127
XP-C	1-128	84	4	1-128
XP-C	129-256	84	5	1-128
XP-D	1-128	84	6	1-128
XP-D	129-256	84	7	1-128
XP-E	1-128	84	8	1-128
XP-E	129-256	84	9	1-128

<Example>

Selecting PR-B Patch number 10 from an external MIDI device

Transmit data to the XP-30 in the following order. (Values are in decimal.)

Controller number 0 (Bank Select MSB button), value 81

Controller number 32 (Bank Select LSB button), value 1

Program number 10

Selecting Performances

The MIDI messages transmitted by the external MIDI device will be received by the XP-30 to select Performances as shown in the following table.

Group	Number	Bank Select		Program Number
		MSB	LSB	
USER	1-32	80	0	1-32
PR-A	1-32	81	0	1-32
PR-B	1-32	81	1	1-32

In order to select a Performance, the MIDI channel of the transmitting device must match the XP-30's Control Channel parameter (SYSTEM/MIDI/PERFORM MIDI). In order to select the Patch or Rhythm Set of a Part, the transmit channel must match the receive channel of the Part. However if the Control Channel parameter and the receive channel of a Part have the same setting, the Control Channel parameter setting will take priority so that messages received on this channel will select Performances.

Selecting Rhythm Sets

The MIDI messages transmitted by the external MIDI device will be received by the XP-30 to select Rhythm Sets as shown in the following table.

Group	Number	Bank Select		Program Number
		MSB	LSB	
USER	1, 2	80	0	1, 2
PR-A	1, 2	81	0	1, 2
PR-B	1, 2	81	1	1, 2
PR-C	1, 2	81	2	1, 2
PR-D (GM)	1, 2	81	3	1, 2
PR-E	1, 2	81	4	1, 2
XP-A	1-8	84	0	1-8
XP-C	1-8	84	4	1-8
XP-D	1-128	84	6	1-128
XP-D	129-256	84	7	1-128
XP-E	1-128	84	8	1-128
XP-E	129-256	84	9	1-128

In order to select Rhythm Sets, the MIDI channel of the transmitting device must match the receive channel of Part 10 of the Performance. When the XP-30 is shipped, Part 10 is set to MIDI channel 10.

Enjoying Desktop Music

The XP-30 can be controlled by music software running on a computer. This will allow you to create your own songs, and also to select sounds or edit sounds from the computer display. The features available to you when using a computer will vary greatly, depending on the software you use, so it is important that you choose software suited to your needs.

■ Connecting to Your Computer

Two Connection Methods

There are two ways to connect the XP-30 to your computer: by means of the Computer connector, or by using the MIDI connectors.

To make connections via the Computer connector, use a Computer cable to connect the serial port (RS-232C connector) of your computer to the Computer connector of the XP-30.

To make connections via MIDI, you will need a MIDI interface (such as the Roland Super MPU64, etc.). Use MIDI cables to connect the XP-30's MIDI connectors to the MIDI connectors of the MIDI interface, after it has been connected to your computer.

Connect the XP-30 to your computer using the method that is appropriate for your setup.

If you are making connections using MIDI, read from p. (p. 135).

Connecting with Computer Connector

1. Turn off the XP-30, your computer and all peripheral devices.
 - * *To prevent malfunction and/or damage to speakers or other devices, always turn down the volume, and turn off the power on all devices before making any connections.*
2. Set the COMPUTER switch on the rear panel of the XP-30 as the following figure.

In general, set the switch to **PC-2** for PC, and to **Mac** for Apple Macintosh series.



- * *Before changing the setting of the Computer switch, you must first turn off the power on the XP-30.*

- * *This setting determines the transmission speed (baud rate) between your computer and the MIDI sound module (the XP-30), and the setting used by the computer must match the setting on the XP-30. Here we explained how to make the setting on the XP-30. To make settings on your computer, you will need to make settings for your software. If you are using Windows, settings may be different than the above, depending on your driver settings. If so, carefully read the owner's manual that was included with your driver.*

- * *The PC-1 baud rate is 31.25 (kbit/sec), and the PC-2 baud rate is 38.4 (kbit/sec).*

In step 3, the connections will be slightly different depending on the type of computer you are using, so read the section (3a, 3b) that applies to you.

3a. If you're using a PC, connect the computer cable to the serial port (RS-232C) connector on the rear of the computer.

Computer cable: RSC-15AT (sold separately)

This is a 9 pin cable. If you need a 25 pin cable, refer to "Computer Cable Wiring Diagrams" (p. 208) and purchase an appropriate cable.

3b. If you're using an Apple Macintosh computer, connect the computer cable to the modem port or printer port on the rear of the computer.

Computer cable: RSC-15APL (sold separately)

4. Connect the other end of the Computer cable to the COMPUTER connector on the left side of the XP-30.

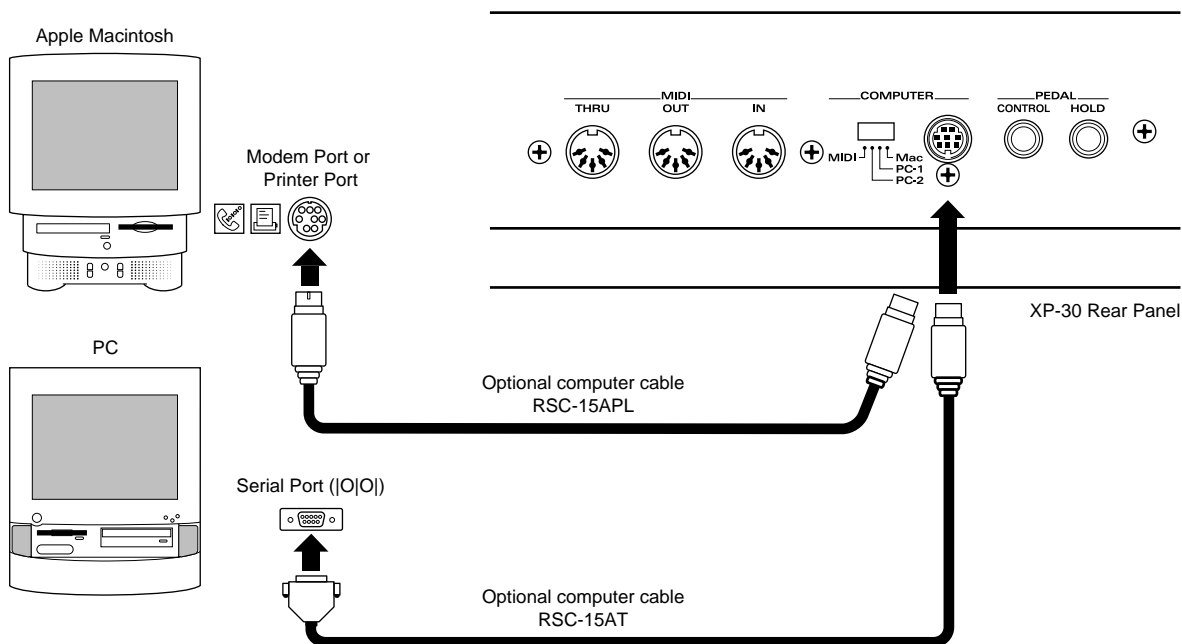

* In order to hear the sounds of the XP-30, you will also need to connect an AC cord, and audio cables or headphones. If you have not yet made connections, please read **“Making Connections”** (p. 24). If you are finished making connections, read from the **“Turning On the Power”** (p. 26).

Connecting with MIDI Connectors

If a MIDI interface (Roland Super MPU64, etc.) is connected to your computer, or if a MIDI interface adaptor is connected, you can use the MIDI connectors to make connections.

* For details on how to install the MIDI interface, refer to the owner’s manual for your MIDI interface.

1. Turn off the XP-30, your computer and all peripheral devices.
- * To prevent malfunction and/or damage to speakers or other devices, always turn down the volume, and turn off the power on all devices before making any connections.
2. Set the COMPUTER switch on the rear panel of the XP-30 to **MIDI**.

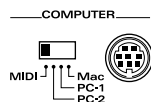

* Before changing the setting of the Computer switch, you must first turn off the power on the XP-30.

Chapter 6. Getting the Full Potential of the XP-30

3. Use a MIDI cable (sold separately) to connect the MIDI OUT connector of the MIDI interface to the MIDI IN connector of the XP-30.
4. Use a MIDI cable to connect the MIDI IN connector on the MIDI interface to the MIDI OUT connector on the XP-30.

* This connection is necessary in order to use the controller section (keyboard section) of the XP-30.

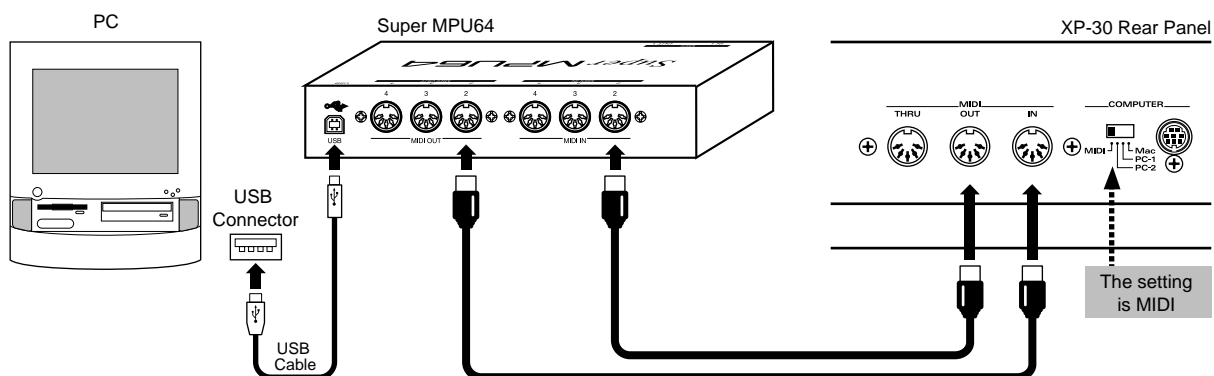
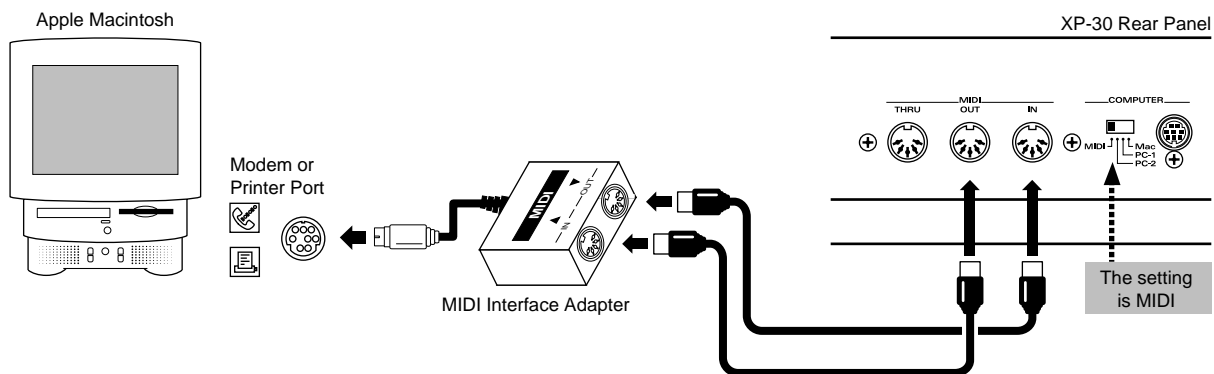

■ Disconnecting the Keyboard from the Internal Sound Source (Local OFF)

The XP-30 contains a controller section (keyboard section) and sound generating section, packaged as a single unit. This means that you can make a setting (Local Control) that specifies whether or not the performance data from the keyboard will be transmitted directly to the sound source. When you use the XP-30 by itself, you will normally set it to Local ON. However, when you are using it as a sound generator for a DTM (desktop music) system, you should set the Local parameter (SYSTEM/MIDI/PERFORM MIDI) to OFF so that the keyboard will be disconnected from the internal sound generator.

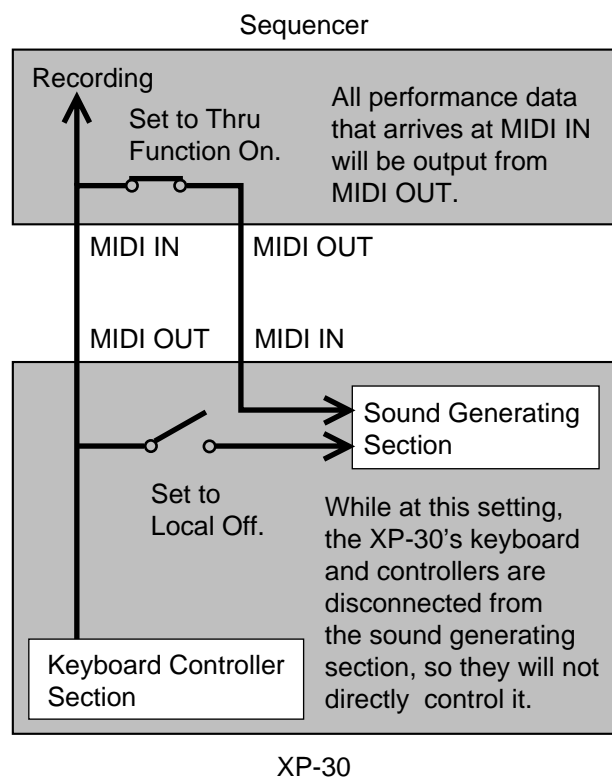

Turn on the Thru Function of Your Sequencer Software

In order for the musical data received by the computer from the XP-30 to be transmitted back to the XP-30, the **Thru function** of the sequencing program must be turned on. When the Thru function of the sequencing program is turned on, MIDI messages received at MIDI IN will be re-transmitted without change from MIDI OUT. For details on whether or not your sequencing program has a Thru function, and how to set the Thru function, refer to the owner's manual for your sequencing program.

- * If your sequencing program does not have a Thru function, set the XP-30's Local Control to ON.
- * For some sequencing programs, System Exclusive messages are not transmitted by the Thru function. If you are using such software and wish to record System Exclusive messages, turn the XP-30's Local Control setting ON.

XP-30

64 VOICE EXPANDABLE SYNTHESIZER

*"Session," "Orchestral" and "Techno Collection" onboard
2x EXPANSION*

Appendices

Troubleshooting

If the this unit does not function in the way you expect, first check the following points. If this does not resolve the problem, consult your dealer or a nearby Roland Service Station (listed at the end of this manual).

* *If a message appears during operation, consult the following section “Error Messages” (p. 142)*

Cannot Turn the Power On

- Is the power cable correctly plugged into an outlet?

No Sound

- Is the power turned on for the other devices connected to the this unit?
- Is the VOLUME slider turned all the way down?
- Are the connections correct?

When using the XP-30 by itself, connect audio cables or headphones (p. 24).

When using the XP-30 with a computer, use a Computer cable or MIDI cables to connect it to the computer (p. 134).

You will also need to connect audio cables or headphones (p. 24).

- Can you hear sound through headphones?

If you can hear sound through headphones, the problem may be that the audio cable transmitting the sound to the other devices is broken or incorrectly connected, or that there is a problem with your mixer/amp/speaker system.

- If you do not hear sound when you play the keyboard, check whether the Local Switch, a System parameter, is turned OFF.

Set the Local parameter (SYSTEM/MIDI/PATCH MIDI, PERFORM MIDI, GM MIDI) to ON (p. 112).

- If a layer-type performance is selected, has the Local switch of the part been turned off?

Set the Local parameter (PERFORM/MIDI/MIDI) to ON (p. 86).

- Have all tones in the patch been turned off?

Press the TONE SWITCH [1]–[4] buttons to make the indicators light.

- If you have selected settings that use an XP-D or E Wave, Patch, or Rhythm Set, is the specified Wave Expansion Board installed correctly? (p. 16, 20)

- Has the volume been lowered by pedal operations or by MIDI messages (volume messages or expression messages) received from an external MIDI device?

Use the Panic function to raise the volume (p. 60).

If you are in Performance mode, access the INFO display (PERFORM/INFO) to check the settings of the Volume message (Vol) and Expression message (Exp) parameters, and make the appropriate settings.

- Is the rear panel COMPUTER switch set to the correct position?

If you are using the XP-30 while connected to a computer, make settings as appropriate for the connection method, the type of computer, and the settings of the driver (p. 134).

* *Turn off the XP-30's power before changing the position of the COMPUTER switch.*

Song Does Not Playback Correctly

- Are you playing a GS format song?

The XP-30 is compatible with the General MIDI System, but not with the GS format, so a GS format song will not play back correctly on the XP-30.

- When playing back a GM score, is the sound source set to GM mode?

Enter GM Mode (p. 124).

- Has the Receive GM Exclusive switch been turned ON? Set the Rx.GM parameter (SYSTEM/MIDI/SYS-EXC MIDI) to ON (p. 113).

A Specific Part Does Not Sound

- Has the volume level of the part been lowered?

Adjust the Level parameter (PERFORM/PART/SETTING) to raise the volume of the part that is not heard (p. 87).

- Is the instrument set to receive MIDI messages?

Set the Rx parameter (PERFORM/MIDI/MIDI) to ON (p. 86).

- Does the MIDI Receive channel of the Part match the MIDI Transmit channel of the connected MIDI device? Set the Channel parameter (PERFORM/MIDI/MIDI) to specify the MIDI receive channel (p. 86).

No Sound from Connected MIDI Device

- Is the instrument set to transmit MIDI messages?

In the Patch mode, make the setting for the Tx-Ch parameter (SYSTEM/MIDI/PATCH MIDI) (p. 112).

In the Performance mode, set the Tx parameter (PERFORM/MIDI/MIDI) to ON (p. 86).

- Does the MIDI send channel for the XP-30's controller match the MIDI receive channel for the connected MIDI instrument?

In the Patch mode, make the setting for the Tx-Ch parameter (SYSTEM/MIDI/PATCH MIDI) (p. 112).

In the Performance mode, set the MIDI send channel with the Channel parameter (PERFORM/MIDI/MIDI) (p. 86).

A Specific Keyboard Area Does Not Sound

- Has a restricted range of notes been set?

If a specific range of notes does not sound, check the Key Range settings for the patch and performance in the KEY RANG display (PATCH/COMMON) and KEY RANG display (PERFORM/COMMON). If both key ranges have been set, only the notes specified in both settings will sound.

Sound Is Distorted

- Is an effect which distorts the sound being applied? (p. 93)
- If the sound is distorted for specific patches or parts, lower the volume level of those patches or parts (p. 81, 87).
- If all sounds are distorted, use the VOLUME slider to lower the volume level.

Pitch Is Incorrect

- Is the tuning of the XP-30 incorrect?

Check the Master parameter (SYSTEM/TUNE/TUNE) (p. 113).

- Has the pitch been changed by pedal operations or by pitch change messages received from an external MIDI device?

Use the Panic function to reset the original values (p. 60).

If you are in Performance mode, access the INFO display (PERFORM/INFO) to check the settings of the Pitch Bend Message parameter (Bend), and make the appropriate settings (p. 87).

- Have the Coarse Tune or Fine Tune parameters been set for specific parts?

Check the Coarse parameter and Fine parameter (PERFORM/PART/SETTING) (p. 87).

Effects Do Not Apply

- Is the effect switch turned OFF for Multi-Effects, Chorus, or Reverb?

To check these settings, press [EFFECTS ON/OFF] (p. 62).

Sounds Are Interrupted

- If you attempt to play more than 64 voices at once, sounds will be interrupted (p. 42).

Reduce the number of Tones that you are using (p. 50, 76).

Increase the Voice Reserve setting for parts that must not drop out (p. 87).

Exclusive Messages Are Not Received

- Does the Device ID number of the transmitted exclusive message match the Device ID number of this unit?

Check the Device# parameter (SYSTEM/MIDI/SYS-EXC MIDI) (p. 113).

This Unit Does Not Transmit MIDI Data

- If you wish to transmit this unit data via the Computer connector, set the COMPUTER switch to PC-1, PC-2 or Mac, depending on the computer or software you are using (p. 134).

- When the rear panel COMPUTER switch is set to MIDI, this unit will not transmit data from the COMPUTER connector. In this case, data will be transmitted from the MIDI OUT connector.

When Using Sequencing Software, Operating the Sliders or Other Controls Does Not Affect the Sound

- Some sequencer software does not "soft-thru" system exclusive messages. If you are using this type of sequencer software and wish to record system exclusive messages, turn the XP-30's Local parameter ON (p. 112).

Error Messages

If there has been a mistake in operation, or if the XP-30 is unable to continue processing as you directed, an error message will appear in the display. Take the appropriate action for the displayed error message. This section gives the error messages in alphabetical order.

Battery Low

Situation: The internal backup battery that is preserving the contents of user memory has run down.

Action: Consult your dealer or a nearby Roland service station to have the battery replaced.

File Format Error

Situation: The XP-30 cannot handle this file.

File I/O Error

Situation: It was not possible to save/load a file.

Action: Try the operation once again. If the same message appears, that file has been damaged. Delete the damaged file.

File Name Duplicate

Situation: A file of the same name exists on the memory card.

Action: Use a different file name.

File Name Format Error

Situation: A file name has not been assigned.

Action: Assign a file name.

File not Found

Situation: The specified file was not found.

Action: Insert the memory card that contains the specified file, and try the operation once again.

Memory Card Full

Situation: There is insufficient space available on the memory card to save the data.

Action: Either insert a different memory card, or delete unnecessary data and try the operation once again.

Memory Card I/O Error

Situation: It is possible that the memory card has been scratched or otherwise damaged.

Action: If the memory card has been damaged, do not use that memory card. If the same error message appears repeatedly, consult your dealer or a nearby Roland service station.

Memory Card not Ready

Situation: A memory card is not inserted in the MEMORY CARD slot.

Action: Turn off the power, and insert a memory card.

Memory Card Write Protected

Situation: Since a write protect sticker is affixed to the memory card, data cannot be saved to the card bank.

Action: Remove the write protect sticker from the memory card.

MIDI Buffer Full

Situation: Due to an inordinate volume of MIDI messages received, the XP-30 has failed to process them properly.

Action: Reduce the amount of MIDI messages to be transmitted.

MIDI Communication Error

Situation: A problem has occurred with the MIDI cable connections.

Action: Check that MIDI cables are not broken or pulled out.

Receive Data Error

Situation: A MIDI message was received incorrectly.

Action: If the same error message is displayed repeatedly, there is a problem with the MIDI messages that are being transmitted to the XP-30.

Unformatted Memory Card

Situation: This memory card cannot be used by the XP-30.

Action: Format the memory card on the XP-30.

User Memory Damaged

Situation: The data in user memory has been lost.

Action: Use the Factor Reset function (UTILITY/UTIL 2/FACTORY RESET) to initialize the memory to the factory settings.

User Memory Write Protected

Situation 1: The Internal parameter (UTILITY/UTIL 1/PROTECT/WRITE PROTECT) is turned ON.

Action 1: Turn the Internal parameter OFF.

Situation 2: The Exclusive parameter (UTILITY/UTIL 1/PROTECT/WRITE PROTECT) is turned ON, and Exclusive messages cannot be received.

Action 2: Turn the Exclusive parameter OFF.

Quick Reference of Procedures

The XP-30 has a large number of functions. This section gives the procedures for using some of the frequently-used functions. For functions that are used simply by setting the applicable parameter, only the “Parameter name (mode/display group/display)” is listed.

* “[A] + [B]” indicates that you are to hold down [A] and press [B].

■ Patch Mode

Selecting the Patch Mode PLAY Display

Press [PATCH].

Selecting a Patch

Use the VALUE dial, [INC]/[DEC], or numeric keys to select.

Using the Numeric Keys to Select the Patch Group

Press [SHIFT] + numeric keys.

Selecting Patches Using the Digit Hold Function

1. Press [SHIFT] + [ENTER] (turn on the Digit Hold function).
2. Use the numeric keys to specify the number of the one's place.

* To turn off the Digit Hold function, press [SHIFT] + [ENTER] once again.

Transposing the Keyboard by Octave

Press [-OCT] or [+OCT].

Transposing the Keyboard in Semitone Steps

Transpose on/off: press [TRANPOSE]

Lower the keyboard: press [TRANPOSE] + [-OCT]

Raise the keyboard: press [TRANPOSE] + [+OCT]

Modifying a Patch (basic procedure)

1. Make the [EDIT] indicator light.
2. Use the function buttons to select the display group.
3. Use [▲]/[▼] to select the desired display page.
4. Turn off the [EDIT] indicator.
5. Use TONE SELECT [1]–[4] (function buttons) to select the Tone.
6. Use [◀]/[▶] to select a parameter.

7. Use the VALUE dial, [INC]/[DEC], or the numeric keys to modify the value.

* If you wish to move to a different parameter group, turn on the [EDIT] indicator.

Changing the Patch Assigned to a Performance

1. Press [PERFORM] + [PATCH].
2. Use [◀]/[▶] to select a Part.
3. Use the VALUE dial, [INC]/[DEC], or the numeric keys to select a Patch.

The rest is the same as for the basic procedure listed above.

Simultaneously Modifying the Values of Two or More Tones

In a Tone setting display, hold down the TONE SELECT [1]–[4] (function button) for one Tone, and press the button(s) for the other Tone(s) you want to edit.

Adjusting the Volume of a Patch

Level parameter (PATCH/COMMON/PATCH COMMON)

Adjusting the Pan Position of a Patch

Pan parameter (PATCH/COMMON/PATCH COMMON)

■ Performance Mode

Selecting the Performance Mode PLAY Display

Press [PERFORM].

Selecting a Part to Play from the Keyboard (for a Single-Type Performance)

Use [◀]/[▶].

Changing the Patch/Rhythm Set Assigned to a Part

1. Press [PERFORM] + [PATCH].
2. Use [◀]/[▶] to select a Part.
3. Use the VALUE dial, [INC]/[DEC], or the numeric keys to select a Patch or Rhythm Set.

Using the Numeric Keys to Select the Performance/Patch/Rhythm Set Group

Press [SHIFT] + numeric keys.

Selecting Performances Using the Digit Hold Function

1. Press [SHIFT] + [ENTER] (turn on the Digit Hold function).
 2. Use the numeric keys to specify the number of the one's place.
- * To turn off the Digit Hold function, press [SHIFT] + [ENTER] once again.

Modifying a Performance (basic procedure)

1. Make the [EDIT] indicator light.
 2. Use the function buttons to select the display group.
 3. Use [▲]/[▼] to select the desired display page.
 4. Turn off the [EDIT] indicator.
 5. Use [PART] (function button) to select the Tone.
 6. Use [◀]/[▶] to select a parameter.
 7. Use the VALUE dial, [INC]/[DEC], or the numeric keys to modify the value.
- * If you wish to move to a different parameter group, turn on the [EDIT] indicator.

Adjusting the Volume of a Part

1. Turn on the [EDIT] indicator.
2. Press [PART] (function button).
3. Use [▲]/[▼] to select the PART SETTING display.
4. Set the Level parameter.

Adjusting the Pan Position of a Part

1. Turn on the [EDIT] indicator.
2. Press [PART] (function button).
3. Use [▲]/[▼] to select the PART SETTING display.
4. Set the Pan parameter.

Modifying a Rhythm Set (basic procedure)

1. Press [PERFORM] + [PATCH].
2. Use [◀]/[▶] to select Part 10.
3. Use the VALUE dial, [INC]/[DEC], or the numeric keys to select a Rhythm Set.
4. Make the [EDIT] indicator light.
5. Use the function buttons to select the parameter group.

6. Use [▲]/[▼] to select the desired display page.
7. Use [◀]/[▶] to select a parameter.
8. Use the keyboard to select a rhythm instrument.
9. Use the VALUE dial, [INC]/[DEC], or the numeric keys to modify the value.

■ Controller Settings

Changing the Range of the Pitch Bend Lever (for each Patch)

Bend Range parameter (PATCH/CONTROL/KEY MODE&BENDER)

Selecting the MIDI Messages Controlled by the C1–C4 Sliders

Assign parameter (SYSTEM/CONTROL/C1–C4 ASSIGN)

Selecting the MIDI Messages Controlled by the CONTROL PEDAL

Polarity parameter (SYSTEM/CONTROL/CONTROL PEDAL)

Reversing the Polarity of CONTROL PEDAL (when using a pedal of another manufacturer whose polarity is reversed)

Polarity parameter (SYSTEM/CONTROL/CONTROL PEDAL)

Controlling Patch Parameters with a Slider or Pedal

You can specify up to three control sources (MIDI messages used for control). However control source 1 is fixed at “modulation”. For each control source, you can specify up to four control destinations (parameters to be controlled).

1. Specify the MIDI message to be controlled by each controller (C1–C4, CONTROL PEDAL) (see above).
2. Select the control source.
Control 2/3 parameter (PATCH/CONTROL/CONTROL SOURCE)
3. Specify the control destination (the parameter to be controlled).
Destination parameter (PATCH/CONTROL/CONTROL1–3)

* If you do not need to set different control sources for each Patch, set the Control 2/3 parameters (PPATCH/CONTROL/CONTROL SOURCE) to “SYS-CTRL1” or “SYS-CTRL2,” and set the Control 1/2 parameters (SYSTEM/CONTROL/SYS-CTRL ASSIGN) to the MIDI messages that you wish to use for control.

Adjusting the Keyboard Response

Sens parameter (SYSTEM/CONTROL/KEYBOARD)

Set the Keyboard to Produce a Fixed Velocity

Vel parameter (SYSTEM/CONTROL/KEYBOARD)

■ Saving and Loading Data

* After completing these procedures, press [UTIL/CARD] to return to the PLAY display.

Formatting a Memory Card

1. Press [UTIL/CARD].
2. Select "1: CARD" on the UTIL 2 display.
3. Select "1: FORMAT."
4. Press [ENTER].

Saving Patch Settings

1. In Patch mode, press [UTIL/CARD].
2. Select "1: WRITE" on the UTIL 1 display.
3. Specify the writing destination.
4. Press [ENTER].

If a message of "Internal Write Protect=ON" appears, change it to "OFF" and press [ENTER] twice.

* If you wish to hear the sound of the Patch in the selected writing destination, press [UNDO/COMPARE]. Press it once again to return to the previous display.

Saving Performance Settings

1. In Performance mode, press [UTIL/CARD].
2. Select "1: WRITE" on the UTIL 1 display.
3. Specify the writing destination.
4. Press [ENTER].

If a message of "Internal Write Protect=ON" appears, change it to "OFF" and press [ENTER] twice.

Saving Rhythm Set Settings

1. In Rhythm Set mode, press [UTIL/CARD].
2. Select "1: WRITE" on the UTIL 1 display.
3. Specify the writing destination.
4. Press [ENTER].

If a message of "Internal Write Protect=ON" appears, change it to "OFF" and press [ENTER] twice.

Saving User Memory Settings and System Settings to Memory Card as a Unit

1. Press [UTIL/CARD].
2. Select "3: SAVE" on the UTIL 2 display.
3. Assign a file name.
4. Press [ENTER].

Deleting a File from Memory Card

1. Press [UTIL/CARD].
2. Select "1: CARD" on the UTIL 2 display.
3. Select "3: DELETE."
4. Select the file that you wish to delete.
5. Press [ENTER].

Checking the Free Area of a Memory Card, etc.

1. Press [UTIL/CARD].
2. Select "1: CARD" on the UTIL 2 display.
3. Select "4: INFO."

■ Controlling External MIDI Devices

Changing the Transmit Channel for Patch Mode

Tx-Ch parameter (SYSTEM/MIDI/PATCH MIDI)

Changing the Transmit Channel for Performance Mode (for each Part)

Channel parameter (PERFORM/MIDI/MIDI)

* Keyboard and controller movements (MIDI messages) from the controller section are transmitted differently depending on whether a single-type Performance or a layer-type Performance is selected. If a single-type Performance is selected, MIDI messages will be transmitted on the MIDI channel of the Part that is being played by the keyboard. If a layer-type Performance is selected, MIDI messages will be transmitted on the MIDI channel of the Parts whose Tx parameter (PERFORM/MIDI/MIDI) is turned ON.

Turning Off Transmission of Program Change/Bank Select MIDI Messages (System)

TRANSMIT MIDI display (SYSTEM/MIDI)

Transmitting Bank Select Messages for the Patch Assigned to a Specific Part when a Performance is Selected

1. Set the Bank Select Group parameter (PERFORM/MIDI/TRANSMIT) to the desired Bank Select Group number (BS1-BS7).
2. Save the Performance.
3. In the BANK SEL-GROUP display (SYSTEM/MIDI/BANK SEL-GROUP), select the Bank Select Group that you specified in step 1.
4. Turn the Switch parameter ON, and specify the MSB and LSB.

■ Controlling the XP-30 from an External MIDI Device

Changing the Receive Channel on which Performances will be Selected

Control Channel parameter (SYSTEM/MIDI/PERFORM MIDI)

Changing the Receive Channel of a Part (Performance)

Channel parameter (PERFORM/MIDI/MIDI)

Changing the Receive Channel (Patch)

Rx-Ch parameter (SYSTEM/MIDI/PATCH MIDI)

Turning Off Reception of Program Change/Bank Select MIDI Messages (System)

RECEIVE MIDI display (SYSTEM/MIDI)

Turning Reception of Volume/Hold 1/Program Change MIDI Messages ON/OFF for Each Part (Performance)

Rx SWITCH display (PERFORM/MIDI)

Turning Reception of Volume/Pan/Pitch Bend/Hold 1/Redamper MIDI Messages ON/OFF for Each Tone (Patch)

Rx SWITCH/DAMPER display (PATCH/CONTROL)

Checking the MIDI Message Reception Status (Performance mode)

INFO display (PERFORM/INFO)

■ Other

Using the Panic Function

Press [SHIFT] + [PANIC].

Adjusting the Tuning

Master parameter (SYSTEM/TUNE/TUNE)

Adjusting the Display Contrast

LCD Contrast parameter (SYSTEM/SETUP/SYSTEM SETUP)

Restoring the Temporary Performance/Patch/Rhythm Set to the Factory Setting

1. Select a Performance, Patch, or Rhythm Set.
2. Press [UTIL/CARD].
3. Select "3: INIT" on the UTIL 1 display.
4. Select "PRESET".
5. Press [ENTER].

Restoring the XP-30 to the Factory Settings

1. Select a Performance, Patch, or Rhythm Set.
2. Press [UTIL/CARD].
3. Select "4: FACTORY RESET" on the UTIL 2 display.
4. Press [ENTER].

Parameter List

■ Patch Parameters

* Parameters that can be set independently for each Tone are indicated by "T."

COMMON Group (p. 68)

Display	Parameter	Value	
PATCH NAME	—	Patch name	ASCII Characters (max. 12)
PATCH CATEGORY	Category	Patch category	(*1)
PATCH CLOCK	Source	Patch clock source	PATCH, SYSETEM
	Tempo	Patch tempo	20–250
PATCH COMMON	Level	Level	0–127
	Pan	Pan	L64–0–63R
	Analog Feel	Analog feel depth	0–127
	Octave	Octave shift	-3–0–+3
	Stretch	Stretch tune depth	OFF, 1, 2, 3
	Priority	Voice priority	LAST, LOUDEST
	VelRang	Velocity range switch	OFF, ON
VELOCITY	Lower	Velocity range lower	1–Upper T
	Upper	Velocity range upper	Lower–127 T
	Cross Fade	Velocity cross fade	0–127 T
KEY RANG	Lower	Key range lower	C-1–Upper T
	Upper	Key range upper	Lower–G9 T
STRUCT	Type	Structure type	1–10 T
	Booster	Booster gain	0, +6, +12, +18 dB T

*1: NO ASSIGN, AC.PIANO, EL.PIANO, KEYBOARDS, BELL, MALLETT, ORGAN, ACCORDION, HARMONICA, AC.GUITAR, EL.GUITAR, DIST.GUITAR, BASS, SYNTH BASS, STRINGS, ORCHESTRA, HIT&STAB, WIND, FLUTE, AC.BRASS, SYNTH BRASS, SAX, HARD LEAD, SOFT LEAD, TECHNO SYNTH, PULSATING, SYNTH FX, OTHER SYNTH, BRIGHT PAD, SOFT PAD, VOX, PLUCKED, ETHNIC, FRETTED, PERCUSSION, SOUND FX, BEAT&GROOVE, DRUMS, COMBINATION

EFFECTS Group (p. 71)

Display	Parameter	Value	
OUTPUT	Output Assign	Output assign	MIX, EFX T
		Output level	0–127 T
	Chorus	Chorus send level	0–127 T
	Reverb	Reverb send level	0–127 T
PATCH EFX TYPE	Type	EFX type	(*1)
PATCH EFX PRM	(*1)	Patch EFX parameter	
PATCH EFX OUT	Mix Out	EFX output level	0–127
	Chorus	Chorus send level	0–127
	Reverb	Reverb send level	0–127
PATCH EFX CTRL	—	EFX control source1, 2	(*2)
	—	EFX control depth1, 2	-63–+63
PATCH CHORUS	Rate	Chorus rate	0–127
	Depth	Chorus depth	0–127
	Delay	Chorus pre delay	0–127
	Fbk	Chorus feedback level	0–127
	Level	Chorus level	0–127
	Out	Chorus output assign	MIX, REV, M+R
PATCH REVERB	Type	Reverb/Delay type	ROOM1, ROOM2, STAGE1, STAGE2, HALL1, HALL2, DELAY, PAN-DLY
	Time	Reverb/Delay time	0–127
	Fbk	Delay feedback level	0–127
	HF Damp	Reverb/Delay HF damp	(*3)
	Level	Reverb/Delay level	0–127

*1: Refer to EFX parameters.

*2: OFF, SYS-CTRL1, SYS-CTRL2, MODULATION, BREATH, FOOT, VOLUME, PAN, EXPRESSION, PITCH BEND, AFTERTOUCHE

*3: 200, 250, 315, 400, 500, 630, 800, 1000, 1250, 1600, 2000, 2500, 3150, 4000, 5000, 6300, 8000 Hz, BYPASS

Parameter List

CONTROL Group (p. 73)

Display	Parameter	Value	
KEY MODE&BENDER	Assign	Key assign mode	POLY, SOLO
	Legato	Solo legato switch	OFF, ON
	Bend Range	Bend range down	-48→0 semitone
Bend range up		0→12 semitone	
PORTAMENTO	Sw	Portamento switch	OFF, ON
	Time	Portamento time	0-127
	Mode	Portamento mode	NORMAL, LEGATO
	Type	Portamento type	RATE, TIME
	Start	Portamento start pitch	PITCH, NOTE
RxSWITCH	Volume	Receive volume switch	OFF, ON
	Pan	Receive pan control switch	OFF, CONT, KEY-ON
	Pitch Bend	Receive pitch bend switch	OFF, ON
DAMPER	Hold-1 RxSwitch	Receive hold-1 switch	OFF, ON
	Redamper	Redamper switch	OFF, ON
PEAK & HOLD	EfxCtrl	EFX control peak/hold	OFF, HOLD, PEAK
	Ctrl 1	Control1 peak/hold	OFF, HOLD, PEAK
	Ctrl 2	Control2 peak/hold	OFF, HOLD, PEAK
	Ctrl 3	Control3 peak/hold	OFF, HOLD, PEAK
CONTROL SOURCE	Control 2	Control source 2	(*1)
	Control 3	Control source 3	(*1)
CONTROL 1	Destination	Control destination 1-4	(*2)
	Depth	Control depth 1-4	-63→+63
CONTROL 2	Destination	Control destination 1-4	(*2)
	Depth	Control depth 1-4	-63→+63
CONTROL 3	Destination	Control destination 1-4	(*2)
	Depth	Control depth 1-4	-63→+63

*1: OFF, SYS-CTRL1, SYS-CTRL2, MODULATION, BREATH, FOOT, VOLUME, PAN, EXPRESSION, PITCH BEND, AFTERTOUCH, LFO1, LFO2, VELOCITY, KEYFOLLOW, PLAYMATE

*2: OFF, PCH, CUT, RES, LEV, PAN, MIX, CHO, REV, PL1, PL2, FL1, FL2, AL1, AL2, pL1, pL2, L1R, L2R

WAVE Group (p. 76)

Display	Parameter	Value	
WAVE	Group	Wave group	INT-A, INT-B, XP-A, XP-B, XP-C, XP-D, XP-E
	Number	Wave number	001-255
	Gain	Wave gain	-6, 0, +6, +12 dB
	Switch	Tone switch	OFF, ON
FXM	Switch	Frequency cross modulation switch	OFF, ON
	Color	Frequency cross modulation color	1-4
	Depth	Frequency cross modulation depth	1-16
TONE DELAY	Mode	Tone delay mode	(*1)
	Time	Tone delay time	0-127/0-880/0-5000 (*2)

*1: NORMAL, HOLD, PLAYMATE, CLOCK-SYNC, KEY-OFF-N, KEY-OFF-D, TEMPO-SYNC

*2: When the Tone Delay Mode parameter is set to "CLOCK-SYNC" this is set as a Note value.

LFO Group (p. 78)

Display	Parameter	Value	
LFO1	Form	LFO form	TRI, SIN, SAW, SQR, TRP, S&H, RND, CHS
	Key Sync	LFO key Sync	OFF, ON
	Rate	LFO rate	0-127, 0-880 (*1)
	ExtSync	LFO external sync	OFF, CLOCK
	Mode	LFO fade mode	ON-IN, ON-OUT, OFF-IN, OFF-OUT
	Delay	LFO delay time	0-127
	Fade	LFO fade time	0-127
	Offset	LFO offset	-100, -50, 0, +50, +100
LFO2	(*2)		
LFO DEPTH1:2	Pitch	Pitch LFO depth 1, 2	-63→+63
	TVF	TVF LFO depth 1, 2	-63→+63
	TVA	TVA LFO depth 1, 2	-63→+63
	Pan	Pan LFO depth 1, 2	-63→+63

*1: When the LFO External Sync parameter is set to "CLOCK" this is set as a Note value.

*2: Same as LFO1.

PITCH Group (p. 79)

Display	Parameter	Value		
PITCH	Coarse	Coarse tune	-48→+48 semitone	T
	Fine	Fine tune	-50→+50 cent	T
	Random	Random pitch depth	0–1200 cent (*1)	T
	Keyfollow	Pitch keyfollow	-100→+200 (*2)	T
PCH ENVELOPE	Envelope Depth	Pitch envelope depth	-12→+12	T
	Velocity Sens	Pitch envelope velocity sens	-100→+150	T
PCH TIME ENV	V-T1	Pitch envelope time1 velocity sens	-100→+100 (*3)	T
	V-T4	Pitch envelope time4 velocity sens	-100→+100 (*3)	T
PCH ENVELOPE	Time Keyfollow	Pitch envelope time keyfollow	-100→+100 (*3)	T
	T1, T2, T3, T4	Pitch envelope time 1–4	0–127	T
	L1, L2, L3, L4	Pitch envelope level 1–4	-63→+63	T

*1: 0, 1, 2, 3, 4, 5, 6, 7, 8, 9, 10, 20, 30, 40, 50, 60, 70, 80, 90, 100, 200, 300, 400, 500, 600, 700, 800, 900, 1000, 1100, 1200

*2: -100, -70, -50, -30, -10, 0, +10, +20, +30, +40, +50, +70, +100, +120, +150, +200

*3: -100, -70, -50, -40, -30, -20, -10, 0, +10, +20, +30, +40, +50, +70, +100

TVF Group (p. 80)

Display	Parameter	Value		
FILTER	Type	Filter type	OFF, LPF, BPF, HPF, PKG	T
	Cut	Cutoff frequency	0–127	T
	Res	Resonance	0–127	T
	Keyfollow	Cutoff frequency keyfollow	-100→+200 (*1)	T
	Env Depth	TVF envelope depth	-63→+63	T
TVF VELOCITY	V-Sens	TVF envelope velocity sens	-100→+150	T
	V-Curve	TVF envelope velocity curve	1–7	T
	V-Resonance	Resonance velocity sens	-100→+150	T
TVF TIME ENV	V-T1	TVF envelope time1 velocity sens	-100→+100 (*2)	T
	V-T4	TVF envelope time4 velocity sens	-100→+100 (*2)	T
	Time Keyfollow	TVF envelope time keyfollow	-100→+100 (*2)	T
TVF ENVELOPE	T1, T2, T3, T4	TVF envelope time 1–4	0–127	T
	L1, L2, L3, L4	TVF envelope level 1–4	0–127	T

*1: -100, -70, -50, -30, -10, 0, +10, +20, +30, +40, +50, +70, +100, +120, +150, +200

*2: -100, -70, -50, -40, -30, -20, -10, 0, +10, +20, +30, +40, +50, +70, +100

TVA Group (p. 81)

Display	Parameter	Value		
TVA	Level	Level	0–127	T
	Pan	Pan	L64–0–63R	T
	V-Sens	TVA envelope velocity sens	-100→+150	T
	V-Curve	TVA envelope velocity curve	1–7	T
BIAS	Bias	Bias level	-100→+100 (*1)	T
	Point	Bias point	C-1–G9	T
	Direction	Bias direction	LOWER, UPPER, LOWER&UPPER, ALL	T
PAN MODULATE	Keyfollow	Pan keyfollow	-100→+100 (*1)	T
	Random	Random pan depth	0–63	T
	Alternate	Alternate pan depth	L63–0–63R	T
TVA TIME ENV	V-T1	TVA envelope time1 velocity sens	-100→+100 (*1)	T
	V-T4	TVA envelope time4 velocity sens	-100→+100 (*1)	T
	Time Keyfollow	TVA envelope time keyfollow	-100→+100 (*1)	T
TVA ENVELOPE	T1, T2, T3, T4	TVA envelope time 1–4	0–127	T
	L1, L2, L3	TVA envelope level 1–3	0–127	T

*1: -100, -70, -50, -40, -30, -20, -10, 0, +10, +20, +30, +40, +50, +70, +100

Parameter List

■ Performance Parameters

* Parameters that can be set independently for each Part are indicated by "P."

COMMON Group (p. 83)

Display	Parameter		Value	
PERFORM NAME	—	Performance name	ASCII Characters (max. 12)	
PERFORM CLOCK	Source	Performance clock source	PERFORM, SYSTEM	
	Tempo	Performance tempo	20–250	
PERFORM COMMON	Key Mode	Key mode	LAYER, SINGLE	
	Key Range	key range switch	OFF, ON	
KEY RANG	Lower	Key range lower	C-1–Upper	P
	Upper	Key range upper	Lower–G9	P
KEYBOARD	Octave Shift	Octave shift	-3→+3	P

EFFECTS Group (p. 84)

Display	Parameter		Value	
OUTPUT	Output Assign	Output assign	MIX, EFX, PATCH	P
		Output level	0–127	P
	Chorus	Chorus send level	0–127	P
	Reverb	Reverb send level	0–127	P
PERFORM EFX TYPE	Type	EFX type	(*1)	
	Source	EFX source	PERFORM, 1–9, 11–16	
PERFORM EFX PRM	(*1)	Performance EFX parameters		
PERFORM EFX OUT	Mix Out	EFX output level	0–127	
	Chorus	Chorus send level	0–127	
	Reverb	Reverb send level	0–127	
PERFORM EFX CTRL		EFX control source 1	(*2)	
		EFX control depth 1	-63→+63	
		EFX control source 2	(*2)	
		EFX control depth 2	-63→+63	
PERFORM CHORUS	Rate	Chorus rate	0–127	
	Depth	Chorus depth	0–127	
	Delay	Chorus pre delay	0–127	
	Fbk	Chorus feedback level	0–127	
	Level	Chorus level	0–127	
	Out	Chorus output assign	MIX, REV, M+R	
PERFORM REVERB	Type	Reverb/Delay type	ROOM1, ROOM2, STAGE1, STAGE2, HALL1, HALL2, DELAY, PAN-DLY	
	Time	Reverb/Delay time	0–127	
	Fbk	Delay feedback level	0–127	
	HF Damp	Reverb/Delay HF damp	(*3)	
	Level	Reverb/Delay level	0–127	

*1: Refer to EFX parameters.

*2: OFF, SYS-CTRL1, SYS-CTRL2, MODULATION, BREATH, FOOT, VOLUME, PAN, EXPRESSION, PITCH BEND, AFTERTOUCH

*3: 200, 250, 315, 400, 500, 630, 800, 1000, 1250, 1600, 2000, 2500, 3150, 4000, 5000, 6300, 8000 Hz, BYPASS

MIDI Group (p. 86)

Display	Parameter		Value	
MIDI	Channel	MIDI channel	1–16	P
	Rx	Receive switch	OFF, ON	P
	Tx	Transmit switch	OFF, ON	P
	Local	Local switch	OFF, ON	P
RxSWITCH	Volume	Receive volume switch	OFF, ON	P
	Hold-1	Receive hold-1 switch	OFF, ON	P
	Program Change	Receive program change switch	OFF, ON	P
TRANSMIT	BankSelectGroup	Transmit bank select group	PATCH, BS1–BS7	P
	Transmit Volume	Transmit volume	0–127, OFF	P

PART Group (p. 87)

Display	Parameter	Value	
PATCH	Group	Patch group	USER, PR-A, PR-B, PR-C, GM, PR-E, XP-A, XP-B, XP-C, XP-D, XP-E
	Number	Patch number	001–256
SETTING	Level	Level	0–127
	Pan	Pan	L64–0–63R
	Coarse	Coarse tune	-48→+48 semitone
	Fine	Fine tune	-50→+50 cent
RESERVE	Voice Reserve	Voice reserve	0–64

INFORMATION Group (p. 87)

Display	Parameter	Value	
INFO	Mod	Modulation information	0–127
	Breath	Breath information	0–127
	Foot	Foot information	0–127
	Vol	Volume information	0–127
	Pan	Pan information	L64–0–63R
	Exp	Expression information	0–127
	Hold	Hold1 information	0–127
	Bend	Pitch bend information	-128→+127
	Aft	Aftertouch information	0–127
	Sys1	System control 1 information	0–127/-128→+127
	Sys2	System control 2 information	0–127/-128→+127
	Voices	Voices information	0–64

■ Rhythm Set Parameters

COMMON Group (p. 88)

Display	Parameter	Value
RHYTHM NAME	—	Rhythm set name ASCII Characters (max. 12)

EFFECTS Group (p. 88)

Display	Parameter	Value	
OUTPUT	Output Assign	Output assign Output level	MIX, EFX 0–127
	Chorus	Chorus send level	0–127
	Reverb	Reverb send level	0–127
	PERFORM EFX TYPE	Type	EFX type (*1)
	Source	EFX source PERFORM, 1–9, 11–16	
PERFORM EFX PRM	(*1)	Performance EFX parameters	
PERFORM EFX OUT	Mix Out	EFX output level	0–127
	Chorus	Chorus send level	0–127
	Reverb	Reverb send level	0–127
PERFORM EFX CTRL		EFX control source 1	(*2)
		EFX control depth 1	-63→+63
		EFX control source 2	(*2)
		EFX control depth 2	-63→+63
PERFORM CHORUS	Rate	Chorus rate	0–127
	Depth	Chorus depth	0–127
	Delay	Chorus pre delay	0–127
	Fbk	Chorus feedback level	0–127
	Level	Chorus level	0–127
	Out	Chorus output assign	MIX, REV, M+R
PERFORM REVERB	Type	Reverb/Delay type	ROOM1, ROOM2, STAGE1, STAGE2, HALL1, HALL2, DELAY, PAN-DLY
	Time	Reverb/Delay time	0–127
	Fbk	Delay feedback level	0–127
	HF Damp	Reverb/Delay HF damp	(*3)
	Level	Reverb/Delay level	0–127

*1: Refer to EFX parameters.

*2: OFF, SYS-CTRL1, SYS-CTRL2, MODULATION, BREATH, FOOT, VOLUME, PAN, EXPRESSION, PITCH BEND, AFTERTOUCH

*3: 200, 250, 315, 400, 500, 630, 800, 1000, 1250, 1600, 2000, 2500, 3150, 4000, 5000, 6300, 8000 Hz, BYPASS

Parameter List

CONTROL Group (p. 90)

Display	Parameter	Value	
CONTROL	Bend Range	Bend range	0–12
	Env Mode	Envelope mode	NO-SUS, SUSTAIN
	Mute Group	Mute group	OFF, 1–31
RxSWITCH	Volume	Receive volume switch	OFF, ON
	Pan	Receive pan control switch	OFF, CONT, KEY-ON
	Hold-1	Receive hold-1 switch	OFF, ON

WAVE Group (p. 90)

Display	Parameter	Value	
WAVE	Group	Wave group	INT-A, INT-B, XP-A, XP-B, XP-C, XP-D, XP-E
	Number	Wave number	001–255
	Gain	Wave gain	-6, 0, +6, +12 dB
	Switch	Key switch	OFF, ON

PITCH Group (p. 91)

Display	Parameter	Value	
PITCH	Coarse	Coarse tune	C-1–G9
	Fine	Fine tune	-50+50 cent
	Random	Random pitch depth	0–1200 cent (*1)
	Env Depth	Pitch envelope depth	-12+12
PCH VELOCITY	Velocity Sens	Pitch envelope velocity sens	-100+150
	Velocity Time	Pitch envelope time velocity sens	-100+100 (*2)
PCH ENVELOPE	T1, T2, T3, T4	Pitch envelope time 1–4	0–127
	L1, L2, L3, L4	Pitch envelope level 1–4	-63+63

*1: 0, 1, 2, 3, 4, 5, 6, 7, 8, 9, 10, 20, 30, 40, 50, 60, 70, 80, 90, 100, 200, 300, 400, 500, 600, 700, 800, 900, 1000, 1100, 1200

*2: -100, -70, -50, -40, -30, -20, -10, 0, +10, +20, +30, +40, +50, +70, +100

TVF Group (p. 91)

Display	Parameter	Value	
FILTER	Type	Filter type	OFF, LPF, BPF, HPF, PKG
	Cutoff	Cutoff frequency	0–127
	Resonance	Resonance	0–127
	Env Depth	TVF Envelope depth	-63+63
TVF VELOCITY	V-Sens	TVF envelope velocity sens	-100+150
	V-Time	TVF envelope time velocity sens	-100+100 (*1)
	V-Resonance	Resonance velocity sens	-100+150
TVF ENVELOPE	T1–4	TVF envelope time 1–4	0–127
	L1–4	TVF envelope level 1–4	0–127

*2: -100, -70, -50, -40, -30, -20, -10, 0, +10, +20, +30, +40, +50, +70, +100

TVA Group (p. 92)

Display	Parameter	Value	
TVA	Level	Level	0–127
	Pan	Pan	L64–0–63R
	Random	Random pan depth	0–63
	Alternate	Alternate pan depth	L63–0–63R
TVA VELOCITY	Velocity Sens	TVA envelope velocity sens	-100+150
	Velocity Time	TVA envelope time velocity sens	-100+100 (*1)
TVA ENVELOPE	T1–4	TVA envelope time 1–4	0–127
	L1–3	TVA envelope level 1–3	0–127

*1: -100, -70, -50, -40, -30, -20, -10, 0, +10, +20, +30, +40, +50, +70, +100

■ GM Mode Parameters

* Parameters that can be set independently for each Part are indicated by "P."

EFFECTS Group (p. 125)

Display	Parameter	Value	
OUTPUT	Output Assign	Output assign	MIX, EFX
		Output level	0–127
	Chorus	Chorus send level	0–127
	Reverb	Reverb send level	0–127
GM EFX TYPE	Type	EFX type	(*1)
GM EFX PRM	(*1)	GM EFX parameters	
GM EFX OUT	Mix Out	EFX output level	0–127
	Chorus	Chorus send level	0–127
	Reverb	Reverb send level	0–127
GM CHORUS	Rate	Chorus rate	0–127
	Depth	Chorus depth	0–127
	Delay	Chorus pre delay time	0–127
	Fbk	Chorus feedback level	0–127
	Level	Chorus level	0–127
GM REVERB	Out	Chorus output assign	MIX, REV, M+R
	Type	Reverb/Delay type	ROOM1, ROOM2, STAGE1, STAGE2, HALL1, HALL2, DELAY, PAN-DLY
	Time	Reverb/Delay time	0–127
	Fbk	Delay Feedback level	0–127
	HF Damp	Reverb/Delay HF damp	(*2)
	Level	Reverb/Delay level	0–127

*1: Refer to EFX parameters.

*2: 200, 250, 315, 400, 500, 630, 800, 1000, 1250, 1600, 2000, 2500, 3150, 4000, 5000, 6300, 8000 Hz, BYPASS

PART Group (p. 127)

Display	Parameter	Value	
PATCH	Number	GMPatch number	001–128
SETTING	Volume	Volume	0–127
	Pan	Pan	L64–0–63R
	Coarse	Coarse tune	-48–+48 semitone
	Fine	Fine tune	-50–+50 cent

INFORMATION Group (p. 127)

Display	Parameter	Value	
INFO	Mod	Modulation information	0–127
	Breath	Breath information	0–127
	Foot	Foot information	0–127
	Vol	Volume information	0–127
	Pan	Pan information	L64–0–63R
	Exp	Expression information	0–127
	Hold	Hold1 information	0–127
	Bend	Pitch bend information	-128–+127
	Aftertouch	Aftertouch information	0–127
	Voices	Voice information	0–64

Parameter List

■ EFX Parameters

1: STEREO-EQ (p. 93)

Parameter		Value
LowFreq	Low frequency	200, 400 Hz
LowGain	Low gain	-15→+15 dB
Hi Freq	High frequency	4000, 8000 Hz
Hi Gain	Hi gain	-15→+15 dB
P1 Freq	Peaking1 frequency	200–8000Hz (*1)
P1 Q	Peaking1 Q	0.5, 1.0, 2.0, 4.0, 8.0
P1 Gain	Peaking1 gain	-15→+15 dB
P2 Freq	Peaking2 frequency	200–8000 Hz (*1)
P2 Q	Peaking2 Q	0.5, 1.0, 2.0, 4.0, 8.0
P2 Gain	Peaking2 gain	-15→+15 dB
Level	Output level	0–127

*1: 200, 250, 315, 400, 500, 630, 800, 1000, 1250, 1600, 2000, 2500, 3150, 4000, 5000, 6300, 8000 Hz

2: OVERDRIVE (p. 93)

Parameter		Value
Drive	Drive	0–127
Level	Output level	0–127
LowGain	Low gain	-15→+15 dB
Hi Gain	High gain	-15→+15 dB
AmpType	Amp simulator type	SMALL, BUILT-IN, 2-STACK, 3-STACK
Pan	Output pan	L64–0–63R

3: DISTORTION (p. 93)

Parameter		Value
Drive	Drive	0–127
Level	Output level	0–127
LowGain	Low gain	-15→+15 dB
Hi Gain	High gain	-15→+15 dB
AmpType	Amp simulator type	SMALL, BUILT-IN, 2-STACK, 3-STACK
Pan	Output pan	L64–0–63R

4: PHASER (p. 94)

Parameter		Value
Manual	Manual	100–8000 Hz
Rate	Rate	0.05–10.00 Hz
Depth	Depth	0–127
Res	Resonance	0–127
Mix	Mix level	0–127
Pan	Output pan	L64–0–63R
Level	Output level	0–127

5: SPECTRUM (p. 94)

Parameter		Value
Band 1	Band1 gain	-15→+15 dB
Band 2	Band2 gain	-15→+15 dB
Band 3	Band3 gain	-15→+15 dB
Band 4	Band4 gain	-15→+15 dB
Band 5	Band5 gain	-15→+15 dB
Band 6	Band6 gain	-15→+15 dB
Band 7	Band7 gain	-15→+15 dB
Band 8	Band8 gain	-15→+15 dB
Q	Q	0.5, 1.0, 2.0, 4.0, 8.0
Pan	Output pan	L64–0–63R
Level	Output level	0–127

6: ENHANCER (p. 94)

Parameter		Value
Sens	Sens	0–127
Mix	Mix level	0–127
Low Gain	Low gain	-15→+15 dB
Hi Gain	High gain	-15→+15 dB
Level	Output level	0–127

7: AUTO-WAH (p. 95)

Parameter		Value
Filter	Filter type	LPF, BPF
Sens	Sens	0–127
Manual	Manual	0–127
Peak	Peak	0–127
Rate	Rate	0.05–10.00 Hz
Depth	Depth	0–127
Level	Output level	0–127

8: ROTARY (p. 95)

Parameter		Value
LowSlow	Low frequency slow rate	0.05–10.00 Hz
LowFast	Low frequency fast rate	0.05–10.00 Hz
LowAccl	Low frequency acceleration	0–15
Low Lvl	Low frequency level	0–127
Hi Slow	High frequency slow rate	0.05–10.00 Hz
Hi Fast	High frequency fast rate	0.05–10.00 Hz
Hi Accl	High frequency acceleration	0–15
Hi Lvl	High frequency level	0–127
Separation	Separation	0–127
Speed	Speed	SLOW, FAST
Level	Output level	0–127

9: COMPRESSOR (p. 96)

Parameter		Value
Attack	Attack	0–127
Sustain	Sustain	0–127
Post Gain	Post gain	0, +6, +12, +18 dB
LowGain	Low gain	-15→+15 dB
Hi Gain	High gain	-15→+15 dB
Pan	Output pan	L64–0–63R
Level	Output level	0–127

10: LIMITER (p. 96)

Parameter		Value
Thresh	Threshold level	0–127
Ratio	Compression ratio	1.5:1, 2:1, 4:1, 100:1
Release	Release time	0–127
Gain	Post gain	0, +6, +12, +18 dB
LowGain	Low gain	-15→+15 dB
Hi Gain	High gain	-15→+15 dB
Pan	Output pan	L64–0–63R
Level	Output level	0–127

11: HEXA-CHORUS (p. 96)

Parameter		Value
Pre Dly	Pre delay time	0.0–100.0 ms
Rate	Rate	0.05–10.00 Hz
Depth	Depth	0–127
Dly Dev	Pre delay deviation	0–20
Dpt Dev	Depth deviation	-20→+20
Pan Dev	Pan deviation	0–20
Balance	Effect balance	D100:0W–D0:100W
Level	Output level	0–127

12: TREMOLO-CHORUS (p. 97)

Parameter		Value
Pre Dly	Pre delay time	0.0–100.0 ms
ChoRate	Chorus rate	0.05–10.00 Hz
Cho Dpt	Chorus depth	0–127
Phase	Tremolo phase	0–180 degree
TrmRate	Tremolo rate	0.05–10.00 Hz
Trm Sep	Tremolo separation	0–127
Balance	Effect balance	D100:0W–D0:100W
Level	Output level	0–127

13: SPACE-D (p. 97)

Parameter		Value
Pre Dly	Pre delay time	0.0–100.0 ms
Rate	Rate	0.05–10.00 Hz
Depth	Depth	0–127
Phase	Phase	0–180 degree
LowGain	Low gain	-15→+15 dB
Hi Gain	High gain	-15→+15 dB
Balance	Effect balance	D100:0W–D0:100W
Level	Output level	0–127

14: STEREO-CHORUS (p. 97)

Parameter		Value
Pre Dly	Pre delay time	0.0–100.0 ms
Rate	Rate	0.05–10.00 Hz
Depth	Depth	0–127
Phase	Phase	0–180 degree
Filter Type	Filter type	OFF, LPF, HPF
Cutoff	Cutoff frequency	200–8000 Hz (*1)
LowGain	Low gain	-15→+15 dB
Hi Gain	High gain	-15→+15 dB
Balance	Effect balance	D100:0W–D0:100W
Level	Output level	0–127

*1: 200, 250, 315, 400, 500, 630, 800, 1000, 1250, 1600, 2000, 2500, 3150, 4000, 5000, 6300, 8000 Hz

15: STEREO-FLANGER (p. 98)

Parameter		Value
Pre Dly	Pre delay time	0.0–100.0 ms
Rate	Rate	0.05–10.00 Hz
Depth	Depth	0–127
Fbk	Feedback level	-98→+98%
Phase	Phase	0–180 degree
Filter Type	Filter type	OFF, LPF, HPF
Cutoff	Cutoff frequency	200–8000 Hz (*1)
LowGain	Low gain	-15→+15 dB
Hi Gain	High gain	-15→+15 dB
Balance	Effect balance	D100:0W–D0:100W
Level	Output level	0–127

*1: 200, 250, 315, 400, 500, 630, 800, 1000, 1250, 1600, 2000, 2500, 3150, 4000, 5000, 6300, 8000 Hz

16: STEP-FLANGER (p. 98)

Parameter		Value
Pre Dly	Pre delay time	0.0–100.0 ms
Rate	Rate	0.05–10.00 Hz
Depth	Depth	0–127
Fbk	Feedback level	-98→+98%
Phase	Phase	0–180 degree
Step Rate	Step rate	0.10–20.00 Hz, note
LowGain	Low gain	-15→+15 dB
Hi Gain	High gain	-15→+15 dB
Balance	Effect balance	D100:0W–D0:100W
Level	Output level	0–127

17: STEREO-DELAY (p. 99)

Parameter		Value
Delay L	Delay time left	0.0–500.0 ms
Delay R	Delay time right	0.0–500.0 ms
Fbk	Feedback level	-98→+98%
Mode	Feedback mode	NORMAL, CROSS
Phase L	Feedback phase left	NORMAL, INVERT
Phase R	Feedback phase right	NORMAL, INVERT
HF Damp	HF damp	200–8000 Hz, BYPASS (*1)
LowGain	Low gain	-15→+15 dB
Hi Gain	High gain	-15→+15 dB
Balance	Effect balance	D100:0W–D0:100W
Level	Output level	0–127

*1: 200, 250, 315, 400, 500, 630, 800, 1000, 1250, 1600, 2000, 2500, 3150, 4000, 5000, 6300, 8000 Hz, BYPASS

18: MODULATION-DELAY (p. 99)

*Parameter	Value
Delay L	Delay time left 0.0–500.0 ms
Delay R	Delay time right 0.0–500.0 ms
Fbk	Feedback level -98→+98%
Mode	Feedback mode NORMAL, CROSS
Rate	Rate 0.05–10.00 Hz
Depth	Depth 0–127
Phase	Phase 0–180 degree
HF Damp	HF damp 200–8000 Hz, BYPASS (*1)
LowGain	Low gain -15→+15 dB
Hi Gain	High gain -15→+15 dB
Balance	Effect balance D100:0W–D0:100W
Level	Output level 0–127

*1: 200, 250, 315, 400, 500, 630, 800, 1000, 1250, 1600, 2000, 2500, 3150, 4000, 5000, 6300, 8000 Hz, BYPASS

19: TRIPLE-TAP-DELAY (p. 100)

Parameter		Value
Delay C	Delay time center	200–1000 ms, note
Delay L	Delay time left	200–1000 ms, note
Delay R	Delay time right	200–1000 ms, note
Fbk	Feedback level	-98→+98%
Level C	Center level	0–127
Level L	Left level	0–127
Level R	Right level	0–127
HF Damp	HF damp	200–8000 Hz, BYPASS (*1)
LowGain	Low gain	-15→+15 dB
Hi Gain	High gain	-15→+15 dB
Balance	Effect balance	D100:0W–D0:100W
Level	Output level	0–127

*1: 200, 250, 315, 400, 500, 630, 800, 1000, 1250, 1600, 2000, 2500, 3150, 4000, 5000, 6300, 8000 Hz, BYPASS

Parameter List

20: QUADRUPLE-TAP-DELAY (p. 101)

Parameter		Value
Delay 1	Delay time 1	200–1000 ms, note
Delay 2	Delay time 2	200–1000 ms, note
Delay 3	Delay time 3	200–1000 ms, note
Delay 4	Delay time 4	200–1000 ms, note
Level 1	Level 1	0–127
Level 2	Level 2	0–127
Level 3	Level 3	0–127
Level 4	Level 4	0–127
Fbk	Feedback level	-98→+98%
HF Damp	HF damp	200–8000 Hz, BYPASS (*1)
Balance	Effect balance	D100:0W–D0:100W
Level	Output level	0–127

*1: 200, 250, 315, 400, 500, 630, 800, 1000, 1250, 1600, 2000, 2500, 3150, 4000, 5000, 6300, 8000 Hz, BYPASS

21: TIME-CONTROL-DELAY (p. 101)

Parameter		Value
Delay	Delay time	200–1000 ms
Accel	Acceleration	0–15
Fbk	Feedback level	-98→+98%
HF Damp	HF damp	200–8000 Hz, BYPASS (*1)
Pan	Output pan	L64–0–63R
LowGain	Low gain	-15→+15 dB
Hi Gain	High gain	-15→+15 dB
Balance	Effect balance	D100:0W–D0:100W
Level	Output level	0–127

*1: 200, 250, 315, 400, 500, 630, 800, 1000, 1250, 1600, 2000, 2500, 3150, 4000, 5000, 6300, 8000 Hz, BYPASS

22: 2 VOICE-PITCH-SHIFTER (p. 102)

Parameter		Value
CoarseA	Coarse pitch A	-24→+12 semitone
Fine A	Fine pitch A	-100→+100 cent
Pan A	Output pan A	L64–0–63R
PreDlyA	Pre delay time A	0.0–500.0 ms
CoarseB	Coarse pitch B	-24→+12 semitone
Fine B	Fine pitch B	-100→+100 cent
Pan B	Output pan B	L64–0–63R
PreDlyB	Pre delay time B	0.0–500.0 ms
Mode	Pitch shifter mode	1, 2, 3, 4, 5
Lvl Bal	Level balance	A100:0B–A0:100B
Balance	Effect balance	D100:0W–D0:100W
Level	Output level	0–127

23: FBK-PITCH-SHIFTER (p. 102)

Parameter		Value
Coarse	Coarse pitch	-24→+12 semitone
Fine	Fine pitch	-100→+100 cent
Fbk	Feedback level	-98→+98%
Pre Dly	Pre delay time	0.0–500.0 ms
Mode	Pitch shifter mode	1, 2, 3, 4, 5
Pan	Output pan	L64–0–63R
LowGain	Low gain	-15→+15 dB
Hi Gain	High gain	-15→+15 dB
Balance	Effect balance	D100:0W–D0:100W
Level	Output level	0–127

24: REVERB (p. 103)

Parameter		Value
Type	Reverb type	ROOM1, ROOM2, STAGE1, STAGE2, HALL1, HALL2
Pre Dly	Pre delay time	0.0–100.0 ms
Time	Gate time	0–127
HF Damp	HF damp	200–8000 Hz, BYPASS (*1)
LowGain	Low gain	-15→+15 dB
Hi Gain	High gain	-15→+15 dB
Balance	Effect balance	D100:0W–D0:100W
Level	Output level	0–127

*1: 200, 250, 315, 400, 500, 630, 800, 1000, 1250, 1600, 2000, 2500, 3150, 4000, 5000, 6300, 8000 Hz, BYPASS

25: GATE-REVERB (p. 103)

Parameter		Value
Type	Gate-Reverb type	NORMAL, REVERSE, SWEEP1, SWEEP2
Pre Dly	Pre delay time	0.0–100.0 ms
Gate Time	Gate time	5–500 ms
LowGain	Low gain	-15→+15 dB
Hi Gain	High gain	-15→+15 dB
Balance	Effect balance	D100:0W–D0:100W
Level	Output level	0–127

26: OVERDRIVE→CHORUS (p. 103)

Parameter		Value
OD Drive	Drive	0–127
OD Pan	Over drive pan	L64–0–63R
Cho Dly	Chorus pre delay time	0.0–100.0 ms
ChoRate	Chorus Rate	0.05–10.00 Hz
Chorus Depth	Chorus depth	0–127
Chorus Balance	Chorus balance	D100:0W–D0:100W
Level	Output level	0–127

27: OVERDRIVE→FLANGER (p. 104)

Parameter		Value
OD Drive	Drive	0–127
OD Pan	Over drive pan	L64–0–63R
Flg Dly	Flanger pre delay time	0.0–100.0 ms
FlgRate	Flanger rate	0.05–10.00 Hz
Flg Dpt	Flanger depth	0–127
Flg Fbk	Flanger feedback level	-98→+98%
Flanger Balance	Flanger balance	D100:0W–D0:100W
Level	Output level	0–127

28: OVERDRIVE→DELAY (p. 104)

Parameter		Value
OD Drive	Drive	0–127
OD Pan	Over drive pan	L64–0–63R
DlyTime	Delay time	0.0–500.0 ms
Dly Fbk	Delay feedback level	-98→+98%
Delay HF Damp	Delay HF damp	200–8000 Hz, BYPASS (*1)
Delay Balance	Delay balance	D100:0W–D0:100W
Level	Output level	0–127

*1: 200, 250, 315, 400, 500, 630, 800, 1000, 1250, 1600, 2000, 2500, 3150, 4000, 5000, 6300, 8000 Hz, BYPASS

29: DISTORTION→CHORUS (p. 104)

The parameters are essentially the same as "26: OVERDRIVE →CHORUS," with the exception of the following two.
OD Drive→Dist Drive, OD Pan→Dist Pan

30: DISTORTION→FLANGER (p. 105)

The parameters are essentially the same as "27: OVERDRIVE →FLANGER," with the exception of the following two.
OD Drive→Dist Drive, OD Pan→Dist Pan

31: DISTORTION→DELAY (p. 105)

The parameters are essentially the same as "28: OVERDRIVE →DELAY," with the exception of the following two.
OD Drive→Dist Drive, OD Pan→Dist Pan

32: ENHANSER→CHORUS (p. 105)

Parameter		Value
Enhancer Sens	Enhancer sens	0–127
Enhancer Mix	Enhancer mix level	0–127
Cho Dly	Chorus pre delay time	0.0–100.0 ms
ChoRate	Chorus rate	0.05–10.00 Hz
Chorus Depth	Chorus depth	0–127
Chorus Balance	Chorus balance	D100:0W–D0:100W
Level	Output level	0–127

33: ENHANSER→FLANGER (p. 105)

Parameter		Value
Enhancer Sens	Enhancer sens	0–127
Enhancer Mix	Enhancer mix level	0–127
Flg Dly	Flanger pre delay time	0.0–100.0 ms
FlgRate	Flanger rate	0.05–10.00 Hz
Flg Dpt	Flanger depth	0–127
Flg Fbk	Flanger feedback level	-98→+98%
Flanger Balance	Flanger balance	D100:0W–D0:100W
Level	Output level	0–127

34: ENHANSER→DELAY (p. 106)

Parameter		Value
Enhancer Sens	Enhancer sens	0–127
Enhancer Mix	Enhancer mix level	0–127
Delay	Delay time	0.0–500.0 ms
Dly Fb	Delay feedback level	-98→+98%
Delay HF Damp	Delay HF damp	200–8000 Hz, BYPASS (*1)
Delay Balance	Delay balance	D100:0W–D0:100W
Level	Output level	0–127

*1: 200, 250, 315, 400, 500, 630, 800, 1000, 1250, 1600, 2000, 2500, 3150, 4000, 5000, 6300, 8000 Hz, BYPASS

35: CHORUS→DELAY (p. 106)

Parameter		Value
Cho Dly	Chorus pre delay time	0.0–100.0 ms
ChoRate	Chorus rate	0.05–10.00 Hz
Cho Dpt	Chorus depth	0–127
Cho Bal	Chorus balance	D100:0W–D0:100W
DlyTime	Delay time	0.0–500.0 ms
Dly Fbk	Delay Feedback level	-98→+98%
Delay HF Damp	Delay HF damp	200–8000 Hz, BYPASS (*1)
Delay Balance	Delay balance	D100:0W–D0:100W
Level	Output level	0–127

*1: 200, 250, 315, 400, 500, 630, 800, 1000, 1250, 1600, 2000, 2500, 3150, 4000, 5000, 6300, 8000 Hz, BYPASS

36: FLANGER→DELAY (p. 106)

Parameter		Value
Flg Dly	Flanger pre delay time	0.0–100.0 ms
FlgRate	Flanger rate	0.05–10.00 Hz
Flg Dpt	Flanger depth	0–127
Flg Fbk	Flanger feedback level	-98→+98%
Flg Bal	Flanger balance	D100:0W–D0:100W
DlyTime	Delay time	0.0–500.0 ms
Dly Fbk	Delay feedback level	-98→+98%
HF Damp	HF damp	200–8000 Hz, BYPASS (*1)
Delay Balance	Delay balance	D100:0W–D0:100W
Level	Output level	0–127

*1: 200, 250, 315, 400, 500, 630, 800, 1000, 1250, 1600, 2000, 2500, 3150, 4000, 5000, 6300, 8000 Hz, BYPASS

37: CHORUS→FLANGER (p. 107)

Parameter		Value
Cho Dly	Chorus pre delay time	0.0–100.0 ms
ChoRate	Chorus rate	0.05–10.00 Hz
Cho Dpt	Chorus depth	0–127
Cho Bal	Chorus balance	D100:0W–D0:100W
Flg Dly	Flanger pre delay time	0.0–100.0 ms
FlgRate	Flanger rate	0.05–10.00 Hz
Flg Dpt	Flanger depth	0–127
Flg Fbk	Flanger feedback level	-98→+98%
Flanger Balance	Flanger balance	D100:0W–D0:100W
Level	Output level	0–127

38: CHORUS/DELAY (p. 107)

Refer to "35: CHORUS→DELAY."

39: FLANGER/DELAY (p. 107)

Refer to "36: FLANGER→DELAY."

40: CHORUS/FLANGER (p. 107)

Refer to "37: CHORUS→FLANGER."

Parameter List

■ System Parameters

SETUP Group (p. 108)

Display	Parameter		Value
SYSTEM SETUP	LCD	LCD contrast	1–10
	Power Up Mode	Power up mode	LAST-SET, DEFAULT
	Patch Remain	Patch remain switch	OFF, ON
	Clock Source	Clock source	INT, MIDI
	System Tempo	System tempo	20–250
	Category Select Mode	Category select mode	LAST-SET, DEFAULT

ARPEGGIO Group (p. 108)

Display	Parameter		Value
ARPEGGIO	Style	Style	(*1)
	Octave Range	Octave range	-3→+3
	Motif	Motif	(*2)
	Beat Pattern	Beat pattern	(*3)
	Accent Rate	Accent rate	0–100%
	Shuffle Rate	Shuffle rate	50–90%
	Key Velocity	Key velocity	REAL, 1–127
	Part	Arpeggio part	1–16
	Tempo	Tempo	20–250

*1: 1/4, 1/6, 1/8, 1/12, 1/16, 1/32, PORTAMENTO A, PORTAMENTO B, GLISSANDO, SEQUENCE A, SEQUENCE B, SEQUENCE C, SEQUENCE D, ECHO, SYNTH BASS, SLAP BASS A, SLAP BASS B, WALK BASS, RHYTHM GTR A, RHYTHM GTR B, RHYTHM GTR C, RHYTHM GTR D, RHYTHM GTR E, 3 FINGER GTR, STRUMMING GTR, KBD COMPING A, KBD COMPING B, KBD COMPING C, KBD COMPING D, KBD COMPING E, PERCUSSION, HARP, SHAMISEN, BOUND BALL, RANDOM, BOSSA NOVA, SALSA, MAMBO, LATIN PERCUSSION, SAMBA, TANGO, HOUSE, LIMITLESS

*2: SINGLE UP, SINGLE DOWN, SINGLE UP&DOWN, SINGLE RANDOM, DUAL UP, DUAL DOWN, DUAL UP&DOWN, DUAL RANDOM, TRIPLE UP, TRIPLE DOWN, TRIPLE UP&DOWN, TRIPLE RANDOM, NOTE ORDER, GLISSANDO, CHORD, BASS+CHORD1–5, BASS+UP1–8, BASS+RANDOM1–3, TOP+UP1–6, BASS+UP+TOP

*3: 1/4, 1/6, 1/8, 1/12, 1/16 1–3, 1/32 1–3, PORTA-A 01–11, PORTA-B 01–15, SEQ-A 1–7, SEQ-B 1–5, SEQ-C 1–2, SEQ-D 1–8, ECHO 1–3, MUTE 01–16, STRUM 1–8, REGGAE1–2, REFRAIN 1–2, PERC1–4, WALKBS, HARP, BOUND, RANDOM, BOSSA NOVA, SALSA 1–4, MAMBO 1–2, CLAVE, REV CLA, GUIRO, AGOGO, SAMBA, TANGO 1–4, HOUSE 1–2

CONTROL Group (p. 110)

Display	Parameter		Value
KEYBOARD	Transpose	Transpose switch	OFF, ON
		Transpose value	-5 (G)→+6 (F#)
	Sens	Keyboard sens	LIGHT, MEDIUM, HEAVY
	Vel	Keyboard velocity	REAL, 1–127
	Aft	Aftertouch sens	0–100
HOLD PEDAL	Output	Pedal output	OFF, INT, MIDI, BOTH
	Polarity	Pedal polarity	STANDARD, REVERSE
CONTROL PEDAL	Assign	Pedal assign	(*1)
	Output	Pedal output	OFF, INT, MIDI, BOTH
	Polarity	Pedal polarity	STANDARD, REVERSE
C1/2/3/4 ASSIGN	Assign	C1/C2/C3/C4 slider assign	(*2)
	Output	C1/C2/C3/C4 slider output	OFF, INT, MIDI, BOTH
SYS-CTRL ASSIGN	Control 1/2	System control assign 1/2	(*2)
CONTROL SOURCE	Hold	Hold control source	OFF, HOLD1, SOST, SOFT, HOLD2
		Peak control source	OFF, HOLD1, SOST, SOFT, HOLD2
	Volume	Volume control source	VOLUME, VOL&EXP
	Aftertouch	Aftertouch control source	CHANNEL, POLY, CH&POLY

*1: CC00–95 (except for 6, 32-63), PITCH BEND, AFTERTOUCH, PROG-UP, PROG-DOWN, TAP-TEMPO, OCT-UP, OCT-DOWN

*2: CC00–95 (except for 6, 32-63), PITCH BEND, AFTERTOUCH

MIDI Group (p. 112)

Display	Parameter		Value
PERFORM MIDI	Control Channel	Performance control channel	1–16, OFF
	Local	Local switch	OFF, ON
	Remote	Remote keyboard switch	OFF, ON
PATCH MIDI	Rx-Ch	Patch mode receive channel	1–16
	Tx-Ch	Patch mode transmit channel	1–16, Rx-Ch, OFF
	Local	Local switch	OFF, ON
	Remote	Remote keyboard switch	OFF, ON
GM MIDI	Local Switch	Local switch	OFF, ON
RECEIVE MIDI	Program Change	Receive program change switch	OFF, ON
	Bank Select	Receive bank select switch	OFF, ON
TRANSMIT MIDI	Program	Transmit program change switch	OFF, ON
	Bank Sel	Transmit bank select switch	OFF, ON
	Active Sensing	Transmit active sensing switch	OFF, ON
SYS-EXC MIDI	Device#	Exclusive device ID number	17–32
	Rx.Exc	Receive exclusive switch	OFF, ON
	Tx.Edit	Transmit edit data switch	OFF, ON
	Rx.GM	Receive GM exclusive switch	OFF, ON
BANK-SEL GROUP	Number	Bank select group number	1–7
	Switch	Bank select transmit switch	OFF, ON
	MSB	Bank select MSB	0–127
	LSB	Bank select LSB	0–127

PREVIEW Group (p. 113)

Display	Parameter		Value
PREVIEW MODE	Mode	Preview sound mode	SINGLE, CHORD, PHRASE
PREVIEW KEY	Note 1–4	Preview Note Set 1–4	C-1–G9
PREVIEW VELOCITY	Note 1–4	Preview velocity	0–127

TUNE Group (p. 113)

Display	Parameter		Value
TUNE	Master	Master tune	427.4–452.6 Hz
	Key Shift	Key shift	-12→+12 semitone
	Scale Tune	Scale tune switch	OFF, ON
PATCH SCALE	C–B	Scale tune C–B	-64→+63 cent
KEY SCALE	C–B	Scale tune C–B	-64→+63 cent

PGM CHNG Group (p. 114)

Display	Parameter		Value
TRANSMIT P.C	Channel	Transmit MIDI channel	1–16
	P.C#	Transmit program change	1–128
	Bank-MSB	Transmit bank select MSB	0–127
	Bank-LSB	Transmit bank select LSB	0–127

INFO Group (p. 114)

Display	Parameter		Value
INFO EXP	Expansion D	Expansion board name D	
	Expansion E	Expansion board name E	
BATTERY CHECK	Internal Battery	Battery check	LOW, OK

Waveform List

INT-A (Internal A)

No.	Name	No.	Name	No.	Name	No.	Name	No.	Name
001	Ac Piano1 A	052	Nylon Gtr A	103	Syn Gtr B	154	MC-202 Bs B	205	Cello A
002	Ac Piano1 B	053	Nylon Gtr B	104	Syn Gtr C	155	MC-202 Bs C	206	Cello B
003	Ac Piano1 C	054	Nylon Gtr C	105	Harp 1A	156	Flute 1A	207	Cello C
004	Ac Piano2 pA	055	6-Str Gtr A	106	Harp 1B	157	Flute 1B	208	ST.Strings-R
005	Ac Piano2 pB	056	6-Str Gtr B	107	Harp 1C	158	Flute 1C	209	ST.Strings-L
006	Ac Piano2 pC	057	6-Str Gtr C	108	Banjo A	159	Blow Pipe	210	MonoStringsA
007	Ac Piano2 fA *	058	Gtr Harm A	109	Banjo B	160	Bottle	211	MonoStringsC
008	Ac Piano2 fB *	059	Gtr Harm B	110	Banjo C	161	Shakuhachi	212	Pizz *
009	Ac Piano2 fC *	060	Gtr Harm C	111	Sitar A	162	Clarinet A	213	JP Strings1A
010	Piano Thump *	061	Comp Gtr A	112	Sitar B	163	Clarinet B	214	JP Strings1B
011	Piano Up TH *	062	Comp Gtr B	113	Sitar C	164	Clarinet C	215	JP Strings1C
012	MKS-20 P3 A	063	Comp Gtr C	114	Dulcimer A	165	Oboe mf A	216	JP Strings2A
013	MKS-20 P3 B	064	Comp Gtr A+	115	Dulcimer B	166	Oboe mf B	217	JP Strings2B
014	MKS-20 P3 C	065	Mute Gtr 1	116	Dulcimer C	167	Oboe mf C	218	JP Strings2C
015	SA Rhodes 1A	066	Mute Gtr 2A	117	Shamisen A	168	Sop.Sax mf A	219	Soft Pad A
016	SA Rhodes 1B	067	Mute Gtr 2B	118	Shamisen B	169	Sop.Sax mf B	220	Soft Pad B
017	SA Rhodes 1C	068	Mute Gtr 2C	119	Shamisen C	170	Sop.Sax mf C	221	Soft Pad C
018	SA Rhodes 2A	069	Pop Strat A	120	Koto A	171	Alto Sax 1A	222	Fantasynt A
019	SA Rhodes 2B	070	Pop Strat B	121	Koto B	172	Alto Sax 1B	223	Fantasynt B
020	SA Rhodes 2C	071	Pop Strat C	122	Koto C	173	Alto Sax 1C	224	Fantasynt C
021	E.Piano 1A	072	Jazz Gtr A	123	Pick Bass A	174	Tenor Sax A	225	D-50 HeavenA
022	E.Piano 1B	073	Jazz Gtr B	124	Pick Bass B	175	Tenor Sax B	226	D-50 HeavenB
023	E.Piano 1C	074	Jazz Gtr C	125	Pick Bass C	176	Tenor Sax C	227	D-50 HeavenC
024	E.Piano 2A	075	JC Strat A	126	Fingerd Bs A	177	Bari.Sax f A	228	Fine Wine
025	E.Piano 2B	076	JC Strat B	127	Fingerd Bs B	178	Bari.Sax f B	229	D-50 Brass A
026	E.Piano 2C	077	JC Strat C	128	Fingerd Bs C	179	Bari.Sax f C	230	D-50 Brass B
027	E.Piano 3A	078	JC Strat A+	129	E.Bass	180	Harmonica A	231	D-50 Brass C
028	E.Piano 3B	079	JC Strat B+	130	Fretless A	181	Harmonica B	232	D-50 BrassA+
029	E.Piano 3C	080	JC Strat C+	131	Fretless B	182	Harmonica C	233	DualSquare A
030	MK-80 EP A	081	Clean Gtr A	132	Fretless C	183	Chanter	234	DualSquare C
031	MK-80 EP B	082	Clean Gtr B	133	UprightBs 1	184	Tpt Sect. A	235	DualSquareA+
032	MK-80 EP C	083	Clean Gtr C	134	UprightBs 2A	185	Tpt Sect. B	236	Pop Voice
033	D-50 EP A	084	Stratus A	135	UprightBs 2B	186	Tpt Sect. C	237	Syn Vox 1
034	D-50 EP B	085	Stratus B	136	UprightBs 2C	187	Trumpet 1A	238	Syn Vox 2
035	D-50 EP C	086	Stratus C	137	Slap Bass 1	188	Trumpet 1B	239	Voice Aahs A
036	Celesta	087	OD Gtr A	138	Slap & Pop	189	Trumpet 1C	240	Voice Aahs B
037	Music Box	088	OD Gtr B	139	Slap Bass 2	190	Trumpet 2A	241	Voice Aahs C
038	Clav 1A	089	OD Gtr C	140	Slap Bass 3	191	Trumpet 2B	242	Voice Oohs1A
039	Clav 1B	090	OD Gtr A+	141	Jz.Bs Thumb	192	Trumpet 2C	243	Voice Oohs1B
040	Clav 1C	091	Heavy Gtr A	142	Jz.Bs Slap 1	193	HarmonMute1A	244	Voice Oohs1C
041	Organ 1	092	Heavy Gtr B	143	Jz.Bs Slap 2	194	HarmonMute1B	245	Voice Oohs2A
042	Jazz Organ 1	093	Heavy Gtr C	144	Jz.Bs Slap 3	195	HarmonMute1C	246	Voice Oohs2B
043	Jazz Organ 2	094	Heavy Gtr A+	145	Jz.Bs Pop	196	Trombone 1	247	Voice Oohs2C
044	Organ 2	095	Heavy Gtr B+	146	Syn Bass A	197	French 1A	248	Voice Breath
045	Organ 3	096	Heavy Gtr C+	147	Syn Bass C	198	French 1C	249	Male Ooh A
046	Organ 4	097	PowerChord A	148	Mini Bs 1A	199	F.Horns A	250	Male Ooh B
047	Rock Organ	098	PowerChord B	149	Mini Bs 1B	200	F.Horns B	251	Male Ooh C
048	Dist. Organ	099	PowerChord C	150	Mini Bs 1C	201	F.Horns C	252	Org Vox A
049	Rot.Org Slw	100	EG Harm	151	Mini Bs 2	202	Violin A	253	Org Vox B
050	Rot.Org Fst	101	Gt.FretNoise *	152	Mini Bs 2+	203	Violin B	254	Org Vox C
051	Pipe Organ	102	Syn Gtr A	153	MC-202 Bs A	204	Violin C	255	Vox Noise

: Waveform marked "" are One-shot type waveforms (non-sustaining).

INT-B (Internal B)

No.	Name	No.	Name	No.	Name	No.	Name
001	Kalimba	052	Feedbackwave	103	Cowbell 1 *	154	REV 606HH Op *
002	Marimba Wave	053	Spectrum	104	Wood Block *	155	REV Ride
003	Log Drum	054	BreathNoise *	105	Claves *	156	REV Cup
004	Vibes	055	Rattles	106	Bongo Hi *	157	REV Crash 1 *
005	Bottle Hit	056	Ice Rain	107	Bongo Lo *	158	REV China *
006	Glockenspiel	057	Tin Wave	108	Cga Open Hi *	159	REV DrySick *
007	Tubular	058	Anklungs	109	Cga Open Lo *	160	REV RealCLP *
008	Steel Drums	059	Wind Chimes	110	Cga Mute Hi *	161	REV FingSnap *
009	Fanta Bell A	060	Orch. Hit *	111	Cga Mute Lo *	162	REV Cowbell *
010	Fanta Bell B	061	Tekno Hit *	112	Cga Slap *	163	REV WoodBlck *
011	Fanta Bell C	062	Back Hit *	113	Timbale *	164	REV Clve *
012	FantaBell A+	063	Philly Hit *	114	Cabasa Up *	165	REV Conga *
013	Org Bell	064	Scratch 1 *	115	Cabasa Down *	166	REV Tamb *
014	Agogo	065	Scratch 2	116	Cabasa Cut *	167	REV Maracas *
015	DIGI Bell 1	066	Scratch 3 *	117	Maracas *	168	REV Guiro *
016	DIGI Bell 1+	067	Natural SN1	118	Long Guiro *	169	REV Cuica *
017	DIGI Chime	068	Natural SN2 *	119	Tambourine *	170	REV Metro *
018	Wave Scan	069	Piccolo SN *	120	Open Triangl	171	Loop 1
019	Wire String	070	Ballad SN *	121	Cuica *	172	Loop 2
020	2.2 Bellwave	071	SN Roll *	122	Vibraslap	173	Loop 3
021	2.2 Vibwave	072	808 SN *	123	Timpani	174	Loop 4
022	Spark VOX	073	Brush Slap *	124	Applause	175	Loop 5
023	MMM VOX	074	Brush Swish *	125	REV Orch.Hit *	176	Loop 6
024	Lead Wave	075	Brush Roll	126	REV TeknoHit *	177	Loop 7
025	Synth Reed	076	Dry Stick *	127	REV Back Hit *	178	R8 Click *
026	Synth Saw 1	077	Side Stick *	128	REV PhillHit *	179	Metronome 1
027	Synth Saw 2	078	Lite Kick *	129	REV Steel DR	180	Metronome 2 *
028	Syn Saw 2inv	079	Hybrid Kick1 *	130	REV Tin Wave	181	MC500 Beep 1 *
029	Synth Saw 3	080	Hybrid Kick2 *	131	REV NatrISN1 *	182	MC500 Beep 2 *
030	JP-8 Saw A	081	Old Kick *	132	REV NatrISN2 *	183	Low Saw
031	JP-8 Saw B	082	Verb Kick *	133	REV PiccloSN *	184	Low Saw inv
032	JP-8 Saw C	083	Round Kick *	134	REV BalladSN *	185	Low P5 Saw
033	P5 Saw A	084	808 Kick	135	REV Side Stk *	186	Low Pulse 1
034	P5 Saw B	085	Verb Tom Hi *	136	REV SN Roll *	187	Low Pulse 2
035	P5 Saw C	086	Verb Tom Lo *	137	REV Brush 1 *	188	Low Square
036	D-50 Saw A	087	Dry Tom Hi	138	REV Brush 2 *	189	Low Sine
037	D-50 Saw B	088	Dry Tom Lo	139	REV Brush 3	190	Low Triangle
038	D-50 Saw C	089	Cl HiHat 1 *	140	REV LiteKick *	191	Low White NZ
039	Synth Square	090	Cl HiHat 2 *	141	REV HybridK1 *	192	Low Pink NZ
040	JP-8 SquareA	091	Op HiHat	142	REV HybridK2 *	193	DC
041	JP-8 SquareB	092	Pedal HiHat *	143	REV Old Kick *		
042	JP-8 SquareC	093	606 HiHat Cl *	144	REV Timpani *		
043	Synth Pulse1	094	606 HiHat Op	145	REV VerbTomH *		
044	Synth Pulse2	095	808 Claps *	146	REV VerbTomL *		
045	Triangle	096	Hand Claps *	147	REV DryTom H		
046	Sine	097	Finger Snaps *	148	REV DryTom M		
047	Org Click *	098	Ride 1	149	REV ClHiHat1 *		
048	White Noise	099	Ride 2	150	REV ClHiHat2 *		
049	Pink Noise	100	Ride Bell 1	151	REV Op HiHat *		
050	Metal Wind	101	Crash 1	152	REV Pedal HH *		
051	Wind Agogo	102	China Cym	153	REV 606HH Cl *		

: Waveform marked "" are One-shot type waveforms (non-sustaining).

Waveform List

XP-A (WAVE EXPANSION A: Session)

No.	Name	No.	Name	No.	Name	No.	Name	No.	Name
001	StGrand L pA	043	NylonGt2 p A	085	JP Hollo A	127	Kick Ghost	169	REV TeknHit3
002	StGrand L pB	044	NylonGt2 p B	086	JP Hollo B	128	Snr&Tom MENU *	170	REV Deep K 3
003	StGrand L pC	045	NylonGt2 p C	087	JP Hollo C	129	Loose Snr	171	REV TD7 Kick
004	StGrand R pA	046	NylonGt2 mfA	088	Hard 5ths A	130	Ring Snr	172	REV Dance K2
005	StGrand R pB	047	NylonGt2 mfB	089	Hard 5ths B	131	808 Snr 2	173	REV Dance K3
006	StGrand R pC	048	NylonGt2 mfC	090	Hard 5ths C	132	909 Snr 2	174	REV Mix Kick
007	StGrand L fA	049	NylonGt2 f A	091	Blaster A	133	909 Snr 3	175	REV K.Ghost
008	StGrand L fB	050	NylonGt2 f B	092	Blaster B	134	90's Snare	176	REV LooseSnr
009	StGrand L fC	051	NylonGt2 f C	093	Blaster C	135	Solo Snr	177	REV Ring Snr
010	StGrand R fA	052	P.Bass 3 A	094	Juno Rave A	136	Rap Snr	178	REV 808 Snr2
011	StGrand R fB	053	P.Bass 3 B	095	Juno Rave B	137	Talk Snr	179	REV 909 Snr2
012	StGrand R fC	054	P.Bass 3 C	096	Juno Rave C	138	Jingle Snr	180	REV 909 Snr3
013	OrcStrings A	055	Jazz Bass3 A	097	Wah Gtr MENU *	139	House Snr	181	REV 90's Snr
014	OrcStrings B	056	Jazz Bass3 B	098	Wah Down 1	140	Snr Buzz	182	REV Solo Snr
015	OrcStrings C	057	Jazz Bass3 C	099	Wah Up 1	141	Tiny Snr 2	183	REV Rap Snr
016	Choir Aah A	058	Muted Bass A	100	Wah Down 2	142	Mute Snr	184	REV Talk Snr
017	Choir Aah B	059	Muted Bass B	101	Wah Up 2	143	909 Rim 2	185	REV JnglSnr
018	Choir Aah C	060	Muted Bass C	102	Gtr FX MENU *	144	909 Tom 2	186	REV HouseSnr
019	Choir Mmh A	061	Blow Sax A	103	Gtr Feedback	145	Clp&Snp MENU *	187	REV Snr Buzz
020	Choir Mmh B	062	Blow Sax B	104	Gtr Scrap	146	909 Claps 2	188	REV TinySnr2
021	Choir Mmh C	063	Blow Sax C	105	Gtr Slid Nz	147	HC2 Claps 1	189	REV Mute Snr
022	D.Solo Gtr A	064	T.Sax hrd A	106	Gtr Cut Nz	148	707 Claps	190	REV 909 Rim2
023	D.Solo Gtr B	065	T.Sax hrd B	107	Gtr Slap	149	HC2 Claps 2	191	REV 909 Tom2
024	D.Solo Gtr C	066	T.Sax hrd C	108	FX MENU *	150	FingerSnaps2	192	REV 909 Clp2
025	D.MuteGt p A	067	Flute Vib A	109	Sm.Club	151	FingerSnap 3	193	REV HC2 Clp1
026	D.MuteGt p B	068	Flute Vib B	110	Sm.Club fw	152	Bongo3 MENU *	194	REV 707 Clps
027	D.MuteGt p C	069	Flute Vib C	111	Sm.Club lp	153	Bongo3 Low	195	REV HC2 Clp2
028	D.MuteGt mpA	070	R&R Horns A	112	FX Bell 1	154	Bongo3 High	196	REV F.Snaps2
029	D.MuteGt mpB	071	R&R Horns B	113	FX Bell 1fw	155	Tambrin MENU *	197	REV F.Snap 3
030	D.MuteGt mpC	072	R&R Horns C	114	FX Bell 2	156	Tamb.Short	198	REV Bongo3 L
031	D.MuteGt mfA	073	Solo Tpt. A	115	FX Bell 2fw	157	Tamb.Long	199	REV Bongo3 H
032	D.MuteGt mfB	074	Solo Tpt. B	116	Auhvox	158	CR78 Tamb.	200	REV Tamb.Sht
033	D.MuteGt mfC	075	Solo Tpt. C	117	Tekno Hit 2	159	Shaker MENU2 *	201	REV Tamb.Lng
034	Clean TC 1 A	076	F.AccordionA	118	Tekno Hit 3	160	626 Shaker	202	REV CR78Tamb
035	Clean TC 1 B	077	F.AccordionB	119	Tekno Loop	161	Shaker 3	203	REV 626Shakr
036	Clean TC 1 C	078	F.AccordionC	120	FX Bomb	162	Shaker 4	204	REV Shaker 3
037	Clean TC2 pA	079	Vibraphone A	121	Kick MENU *	163	Shaker 5	205	REV Shaker 4
038	Clean TC2 pB	080	Vibraphone B	122	Deep Kick 3	164	REV Gt Scrap	206	REV Shaker 5
039	Clean TC2 pC	081	Vibraphone C	123	TD7 Kick	165	REV Gt SldNz		
040	Clean TC2 fA	082	VocalWave2 A	124	Dance Kick 2	166	REV Gt CutNz		
041	Clean TC2 fB	083	VocalWave2 B	125	Dance Kick 3	167	REV Gt Slap		
042	Clean TC2 fC	084	VocalWave2 C	126	Mix Kick	168	REV TeknHit2		

*:These are Menu Waveforms. Many different Waveforms are provided, each one assigned to a different key.

● XP-A Menu Waveforms

Menu Waveforms provide multiple Waveforms, with each one assigned to a different key.

97 Wah Gtr MENU			121 Kick MENU			145 Clp&Snp MENU		
Key	No.	Name	Key	No.	Name	Key	No.	Name
C 4	98	Wah Down 1	C 4	122	Deep Kick 3	C 4	146	909 Claps 2
D 4	99	Wah Up 1	D 4	123	TD7 Kick	D 4	147	HC2 Claps 1
E 4	100	Wah Down 2	E 4	124	Dance Kick 2	E 4	148	707 Claps
F 4	101	Wah Up 2	F 4	125	Dance Kick 3	F 4	149	HC2 Claps 2
			G 4	126	Mix Kick	G 4	150	FingerSnaps2
			A 4	127	Kick Ghost	A 4	151	FingerSnap 3
102 Gtr FX MENU			128 Snr&Tom MENU			152 Bongo3 MENU		
Key	No.	Name	Key	No.	Name	Key	No.	Name
C 4	103	Gtr Feedback	C 4	129	Loose Snr	C 4	153	Bongo3 Low
D 4	104	Gtr Scrap	D 4	130	Ring Snr	D 4	154	Bongo3 High
E 4	105	Gtr Slid Nz	E 4	131	808 Snr 2			
F 4	106	Gtr Cut Nz	F 4	132	909 Snr 2	155 Tambrin MENU		
G 4	107	Gtr Slap	G 4	133	909 Snr 3	Key	No.	Name
			A 4	134	90's Snare	C 4	156	Tamb.Short
108 FX MENU			B 4	135	Solo Snr	D 4	157	Tamb.Long
Key	No.	Name	C 5	136	Rap Snr	E 4	158	CR78 Tamb.
C 4	116	Auhvox	D 5	137	Talk Snr			
D 4	109	Sm.Club	E 5	138	Jingle Snr	159 Shaker MENU2		
E 4	110	Sm.Club fw	F 5	139	House Snr	Key	No.	Name
F 4	111	Sm.Club lp	G 5	140	Snr Buzz	C 4	160	626 Shaker
G 4	112	FX Bell 1	A 5	141	Tiny Snr 2	D 4	161	Shaker 3
A 4	113	FX Bell 1fw	B 5	142	Mute Snr	E 4	162	Shaker 4
B 4	114	FX Bell 2	C 6	143	909 Rim 2	F 4	163	Shaker 5
C 5	115	FX Bell 2fw	D 6	144	909 Tom 2			
D 5	117	Tekno Hit 2						
E 5	118	Tekno Hit 3						
F 5	119	Tekno Loop						
G 5	120	FX Bomb						

Waveform List

XP-B (WAVE EXPANSION B: Orchestral)

No.	Name	No.	Name	No.	Name	No.	Name	No.	Name
001	VI Sect A	036	Vas Spicc C	071	Flugelhorn	106	EuroPiano fB	141	Castanets 2
002	VI Sect B	037	Vcs Spicc A	072	Cornet	107	EuroPiano fC	142	Slapstick
003	VI Sect C	038	Vcs Spicc B	073	HarmonMute2A	108	Harpsichord	143	Ratchet
004	Va Sect A	039	Vcs Spicc C	074	HarmonMute2B	109	Celesta A	144	Sleigh Bell
005	Va Sect B	040	Cbs Spicc A	075	HarmonMute2C	110	Celesta B	145	Tambourine
006	Va Sect C	041	Cbs Spicc B	076	Solo Tb A	111	Celesta C	146	Wind Chime 2
007	Vc Sect A	042	Cbs Spicc C	077	Solo Tb B	112	Harp A	147	REV Hit Maj
008	Vc Sect B	043	Multi Spicc	078	Solo Tb C	113	Harp B	148	REV Hit Min
009	Vc Sect C	044	VI Solo Spicc	079	Bass Tb	114	Harp C	149	REV Hit Dim
010	Cb Sect	045	Vc Solo Spicc	080	Tb Sect	115	Glockenspiel	150	REV Bell
011	Multi STR A	046	Multi SI Spicc	081	Tuba	116	Xylophone	151	REV Timp 1
012	Multi STR B	047	STR Attack	082	BRS Ensemble	117	Bass Marimba	152	REV Timp 2
013	Multi STR C	048	Pizzicato 1	083	Brass ff	118	TubularBells	153	REV SNR 1
014	VI Sect Lp	049	Pizzicato 2	084	Full Orch.	119	Church Bells	154	REV SNR 2
015	Va Sect Lp	050	Piccolo	085	Orch Hit Maj	120	Timpani p	155	REV SNR 3
016	Vc Sect Lp	051	Oboe 1A	086	Orch Hit Min	121	Timpani f	156	REV BD 1
017	Cb Sect Lp	052	Oboe 1B	087	Orch Hit Dim	122	Timp Roll p	157	REV BD 2
018	Multi STR Lp	053	Oboe 1C	088	Choir A	123	Timp Roll f	158	REV BD 3
019	VI Solo A	054	Oboe 2A	089	Choir B	124	Concert SNR1	159	REV BD Roll
020	VI Solo B	055	Oboe 2B	090	Choir C	125	Concert SNR2	160	REV Crash
021	VI Solo C	056	Oboe 2C	091	F.Hrn Sc1 Lp	126	Concert SNR3	161	REV Cym Hit
022	Va Solo A	057	Eng.Horn A	092	F.Hrn Sc2 Lp	127	SNR Roll	162	REV Tam Tam
023	Va Solo B	058	Eng.Horn B	093	F.Hrn MuteLp	128	Concert BD 1	163	REV Gong
024	Va Solo C	059	Eng.Horn C	094	Tb Sect Lp	129	Concert BD 2	164	REV PercHit1
025	Vc Solo A	060	Clarinet	095	BRS Ens Lp	130	Concert BD 3	165	REV PercHit2
026	Vc Solo B	061	Bs Clarinet	096	ff Brass Lp	131	BD Roll	166	REV Casta 1
027	Vc Solo C	062	Multi Cla	097	Full Orch Lp	132	Crash Cymbal	167	REV Casta 2
028	Cb Solo	063	Bassoon	098	Breath Wind	133	Crash Cym Lp	168	REV S.Stick
029	Multi Solo 1	064	Multi Reed	099	Breath Atack	134	Cymbal Hit	169	REV Sleigh
030	Multi Solo 2	065	Tnr.Recorder	100	Breath Whisl	135	Tam Tam	170	REV Tamb
031	Vls Spicc A	066	F.Horn Solo	101	Breath Hrmon	136	Gong	171	SNR Set
032	Vls Spicc B	067	F.Horn Sect1	102	EuroPiano pA	137	Perc Hit 1	172	Perc Set 1
033	Vls Spicc C	068	F.Horn Sect2	103	EuroPiano pB	138	Perc Hit 2	173	Perc Set 2
034	Vas Spicc A	069	F.Horn Mute	104	EuroPiano pC	139	Triangle	174	Perc Set 3
035	Vas Spicc B	070	Trumpet 2	105	EuroPiano fA	140	Castanets 1		

XP-C (WAVE EXPANSION C: Techno Collection)

No.	Name	No.	Name	No.	Name	No.	Name	No.	Name
001	PHRASE MENU *	052	JUNO Bowling	103	Uuh Formant	154	TR606 PHH	205	TR707 Snr 2
002	120:House 1 **	053	JUNO Synth	104	Dist Ooh Vox	155	TR707 PHH	206	CR78 Snare
003	120:House 2 **	054	JX Synth	105	Talkbox	156	OHH MENU *	207	Headz Snare
004	120:House 3 **	055	Alpha Wave	106	VOCODER MENU *	157	TR909 OHH 1	208	Deep Snare
005	120:TeknoBNG **	056	Killer	107	TOM MENU *	158	TR909 OHH 2	209	Fat Snare
006	144:Tekno BD **	057	Detuned Saw	108	TR909 Tom	159	TR909 OHH 3	210	Antigua Snr
007	144:TeknoHAT **	058	Fat JP-6	109	TR909 DstTom	160	TR909 DstOHH	211	MC Snare
008	160:Drum'nBs **	059	Euro Dance	110	TR808 Tom	161	TR808 OHH	212	DJ Snare
009	184:Gabba **	060	Noisy 101	111	TR606 Tom	162	TR606 DstOHH	213	Macho Snare
010	132:Detroit **	061	Daft Wave	112	TR606 CmpTom	163	TR707 OHH	214	Clap Snare
011	132:Agogo **	062	Pizzy Techno	113	TR707 Tom	164	CR78 OHH	215	Rage Snare
012	116:Elect'80 **	063	Organ Pizz	114	TR707 CmpTom	165	R8 OHH	216	Indus Snare
013	120:Electro1 **	064	Garage Org	115	Deep Tom	166	Cym OHH	217	TekRok Snare
014	138:Electro2 **	065	FM Club Org	116	Kick Tom	167	CYMBAL MENU *	218	Jungle Snr 1
015	TB Dst Saw	066	Org Chord	117	Natural Tom	168	TR606 Cym 1	219	Jungle Snr 2
016	TB Dst Sqr 1	067	Dist TekGtr1	118	Can Tom	169	TR606 Cym 2	220	Jungle Snr 3
017	TB Dst Sqr 2	068	Dist TekGtr2	119	PERCUSS MENU *	170	TR606 DstCym	221	Jungle Snr 4
018	TB Reso Sqr1	069	GTR FX MENU *	120	TR808 Conga1	171	TR909 Ride	222	SideStiker
019	TB Reso Sqr2	070	JP Siren	121	TR808 Conga2	172	TR909DstRide	223	Ragga Snr 2
020	TB Reso Sqr3	071	Cold Dress	122	Surdo mute	173	TR707 Ride	224	Lo-Fi Snare
021	TB Saw	072	HIT MENU 1 *	123	Surdo open	174	TR909 Crash	225	Jungle Snr 5
022	TB Solid Saw	073	HIT MENU 2 *	124	TMB&SKR MENU *	175	TR909DsCrash	226	Urban Snare
023	TB Reso Saw	074	Beam HiQ	125	Tambourine 2	176	CLAP MENU *	227	Sim Snare
024	TB Square 1	075	Analog Bird	126	Rattle Tamb	177	TR909 Clap	228	Roll Snare
025	TB Square 2	076	ElectronFall	127	TechnoShaker	178	TS Clap	229	KICK MENU 1 *
026	TB Square 3	077	Retro UFO	128	Dance Shaker	179	Clap Stop	230	KICK MENU 2 *
027	Octa Bass	078	Jungle Beep	129	COW&RIM MENU *	180	TR707 Clap	231	TR909 Kick 1
028	Rave Bass	079	PC-2 Machine	130	TR808Cowbell	181	HC2 Dry Clap	232	TR909 Kick 2
029	FM Pluck Bs	080	Dr.Beat	131	TR707Cowbell	182	Scratch Clap	233	Plastic BD 1
030	FM Slide Bs	081	Mental Perc	132	CR78 Cowbell	183	Comp Clap	234	Plastic BD 2
031	Solid Bass	082	May Day Perc	133	TR727 Agogo	184	Claptail	235	TR808 Kick 1
032	JUNO-60 Bass	083	PC-2 Spacers	134	TR909 Rim	185	SNR MENU 1 *	236	TR808 Kick 2
033	SH-5 Bass	084	Techno Scene	135	TR808 Rim	186	SNR MENU 2 *	237	TR808 Kick 3
034	Dirty Bass	085	Pure Psycho	136	TR808 RimLng	187	SNR MENU 3 *	238	TR606 Kick 1
035	Sub Bass	086	TAO Hit	137	TR808 Claves	188	SNR MENU 4 *	239	TR606 Kick 2
036	Jungle Bass	087	Thin Beef	138	CHH MENU 1 *	189	SNR MENU 5 *	240	TR707 Kick 1
037	JP8000 Saw 1	088	Organ Hit 2	139	CHH MENU 2 *	190	TR909 Snr 1	241	TR707 Kick 2
038	JP8000 Saw 2	089	INDUST. MENU *	140	TR909 CHH 1	191	TR909 Snr 2	242	Culture Kick
039	JP-6 Saw	090	PCM Press	141	TR909 CHH 2	192	TR909 Snr 3	243	Optic Kick
040	Techno Saw	091	ElectricDunk	142	TR909 CHH 3	193	TR909 Snr 4	244	Lo-Fi BD
041	SH-1 Square	092	Thrill	143	TR808 CHH 1	194	TR909 Snr 5	245	Wet Kick
042	SH-1 Pulse	093	Drill Hit	144	TR808 CHH 2	195	TR909 Snr 6	246	Video Kick
043	JP8000 PWM	094	MachineShout	145	TR606 CHH	196	TR909 Snr 7	247	JungleKick 1
044	JP8000 FBK	095	Air Gun	146	TR707 CHH	197	TR808 Snr 1	248	Street Kick
045	260 Sub OSC	096	Emergency	147	CR78 CHH	198	TR808 Snr 2	249	Turbo Kick
046	Dist Synth	097	Buzzer	148	Pop CHH	199	TR808 Snr 3	250	JungleKick 2
047	Dist Square	098	Tonality	149	Bristol CHH	200	TR808 Snr 4	251	Tekno Kick
048	P5 Pipe	099	Aah Formant	150	PHH MENU *	201	TR606 Snr 1	252	Sim Kick
049	FM Garage	100	Eeh Formant	151	TR909 PHH 1	202	TR606 Snr 2	253	Amsterdam BD
050	JUNO Pluck	101	lih Formant	152	TR909 PHH 2	203	TR606 Snr 3	254	TR909 Dst BD
051	Funky Synth	102	Ooh Formant	153	TR808 PHH	204	TR707 Snr 1	255	Roll Kick

*: These are Menu Waveforms. Many different Waveforms are provided, each one assigned to a different key.

** : These are the phrase loop waveforms. The numbers (116–184) included in the wave name represent the B.P.M. (tempo) when played at the C4 key. And these waveforms can be synchronized to a device such as a sequencer.

156 OHH MENU			176 CLAP MENU			186 SNR MENU 2			188 SNR MENU 4			229 KICK MENU 1		
Key	No.	Name	Key	No.	Name	Key	No.	Name	Key	No.	Name	Key	No.	Name
C 4	157	TR909 OHH 1	C 4	177	TR909 Clap	C 4	201	TR606 Snr 1	C 4	218	Jungle Snr 1	C 4	231	TR909 Kick 1
C# 4	158	TR909 OHH 2	C# 4	178	TS Clap	C# 4	202	TR606 Snr 2	C# 4	219	Jungle Snr 2	C# 4	232	TR909 Kick 2
D 4		TR909 OHH 4 *	D 4		TR909 Clap 2 *	D 4		606 Snr Dst *	D 4	220	Jungle Snr 3	D 4		TR909 Kick 3 *
D# 4	159	TR909 OHH 3	D# 4	179	Clap Stop	D# 4	203	TR606 Snr 3	D# 4		Jungle Snr 6 *	D# 4	233	Plastic BD 1
E 4	160	TR909 DstOHH	E 4		808 Comp Clp *	E 4	204	TR707 Snr 1	E 4	221	Jungle Snr 4	E 4	234	Plastic BD 2
F 4		TR808 OHH 2 *	F 4	180	TR707 Clap	F 4		TR707 Snr 3 *	F 4		Jungle Snr 7 *	F 4		TR909 Kick 4 *
F# 4	161	TR808 OHH	F# 4	181	HC2 Dry Clap	F# 4	205	TR707 snr 2	F 4	222	SideStickr	F# 4	235	TR808 Kick 1
G 4		TR808 OHH 3 *	G 4		DM Clap *	G 4	206	CR78 Snare	G 4		Cross Snr *	G 4	236	TR808 Kick 2
G# 4	162	TR606 DstOHH	G# 4	182	Scratch Clap	G# 4		Clap Snare 2 *	G# 4		Jungle Rim *	G# 4	237	TR808 Kick 3
A 4		TR707 HH *	A 4		Real Clap *	A 4		Jungle Snr 9 *	A 4	223	Ragga Snr 2	A 4	238	TR606 Kick 1
A# 4	163	TR707 OHH	A# 4		Groove Clap *	A# 4		Rage Snare 2 *	A# 4	224	Lo-fi Snare	A# 4	239	TR606 Kick 2
B 4	164	CR78 OHH	B 4	183	Comp Clap	B 4		Clap Snare 3 *				B 4		606 Dst Kick *
C 5		DM OHH *	C 5	184	Claptail	C 5		Clap Snare 4 *				C 5	240	TR707 Kick 1
C# 5		Hop OHH *	C# 5		909 Clp Fuzz *							C# 5	241	TR707 Kick 1
D 5	165	R8 OHH										D 5	242	Culture Kick
D# 5	166	Cym OHH												
167 CYMBAL MENU			185 SNR MENU 1			187 SNR MENU 3			189 SNR MENU 5			230 KICK MENU 2		
Key	No.	Name	Key	No.	Name	Key	No.	Name	Key	No.	Name	Key	No.	Name
C 4	168	TR606 Cym 1	C 4	190	TR909 Snr 1	C 4	207	Headz Snare	C 4		Jungle Snr 10 *			
C# 4	169	TR606 Cym 2	C# 4	191	TR909 Snr 2	C# 4	208	Deep Snare	C# 4	225	Jungle Snr 5			
D 4	170	TR606 DstCym	D 4	192	TR909 Snr 3	D 4	209	Fat Snare	D 4		Jungle Snr 8 *			
D# 4	171	TR909 Ride	D# 4	193	TR909 Snr 4	D# 4		R&B Snare *	D# 4	226	Urban Snare			
E 4	172	TR909DstRide	E 4	194	TR909 Snr 5	E 4	210	Antigua Snr	E 4		Lite Snare *			
F 4	173	TR707 Ride	F 4		TR909 Snr 8 *	F 4	211	MC Snare	F 4	227	Sim Snare			
F# 4	174	TR909 Crash	F# 4	195	TR909 Snr 6	F# 4	212	DJ Snare	F# 4		Electro Snr *			
G 4	175	TR909DsCrash	G 4	196	TR909 Snr 7	G 4	213	Macro Snare	G 4	228	Roll Snare			
			G# 4		909 Snr Dst *	G# 4		Lofi Snare *						
			A 4		909 Snr Fuzz *	A 4		Pistol Snr *						
			A# 4		TR808 Snr 5 *	A# 4	214	Clap Snare						
			B 4	197	TR808 Snr 1	B 4	215	Rage Snare						
			C 5	198	TR808 Snr 2	C 5	216	Indus Snare						
			C# 5	199	TR808 Snr 3	C# 5	217	TekRok Snare						
			D 5	200	TR808 Snr 4	D 5		Indus Snare *						
			D# 5		TR808 Snr 6 *									

Patch List

USER (User Group)

No.	Name	Voice	Key Assign	No.	Name	Voice	Key Assign
001	Temple of XP	4	POLY	065	Heirborne	4	POLY
002	Power Split	4	POLY	066	Trumpet	2	POLY
003	Symphonique2	4	POLY	067	Glistening	4	POLY
004	Robot Voice	4	POLY	068	Banded Jupe	1	POLY
005	St.Concert	4	POLY	069	Singing'Mini	1	SOLO
006	ViennaStrgs2	4	POLY	070	Chamber Ens2	2	POLY
007	R&R Brass	3	POLY	071	DanceStack 5	4	POLY
008	Disto Stack	4	POLY	072	SA Rhodes 4	4	POLY
009	Tone Wh.Solo	3	POLY	073	Breathy Brs	3	POLY
010	Combing Slow	3	POLY	074	Atmos Harp	4	POLY
011	SessionNyln2	3	POLY	075	303 Bass	2	POLY
012	Celestial 2	4	POLY	076	Flute	1	POLY
013	Poly Brs	4	POLY	077	Perc Hit 2 /	4	POLY
014	DanceStack 1	3	POLY	078	Oldies Organ	2	POLY
015	303 Ow Bass	1	SOLO	079	Dulcimer	2	POLY
016	Flying Waltz	4	POLY	080	Warmer Pad 2	2	POLY
017	Silky Way	2	POLY	081	ARPsychea	4	POLY
018	Simply June	1	POLY	082	Choir 1	3	POLY
019	Solo Vln 1 /	4	POLY	083	Agitato Str2	4	POLY
020	Super Tenor	3	POLY	084	Pure Tibet	1	POLY
021	Metal Solo	4	POLY	085	Flugelhorn 1	2	POLY
022	Creator	3	POLY	086	D-50 Stack	4	POLY
023	Amsterdamer	2	POLY	087	Noiz Mania	4	POLY
024	Techno Pizz	1	POLY	088	Slap Bass 2	1	SOLO
025	SA Rhodes 3	3	POLY	089	Amazing Echo	4	POLY
026	Dim Hit 1	4	POLY	090	Moving Glass	1	POLY
027	Pan Pipes	2	POLY	091	BluesHarp	1	POLY
028	JP-8 Str 1	2	POLY	092	Tria Bells	4	POLY
029	Pretty Bells	2	POLY	093	DirtyOrgan 2	2	POLY
030	Aurora	4	POLY	094	Dawn 2 Dusk	3	POLY
031	Breathy Humz	2	POLY	095	Just Lovely	1	POLY
032	Full Orch.2	4	POLY	096	SquareKeys 2	1	POLY
033	Clean Tele	4	POLY	097	Natural Vlns	2	POLY
034	Dunes	4	POLY	098	Arasian Morn	4	POLY
035	Cyber-Trance	3	POLY	099	Euro-Dance 2	3	POLY
036	RiversOfTime	4	POLY	100	5th Pad	4	POLY
037	F.Hrn Sect5/	3	POLY	101	Liquid Sky	4	POLY
038	DreamVoices2	2	POLY	102	Sci-Fi Bells	3	POLY
039	HeavenlyPad	2	POLY	103	Nomad Perc	3	POLY
040	Sop.Sax mf	2	POLY	104	Orn.Recorder	3	POLY
041	Sweep Clav 2	3	POLY	105	FXM Saw Lead 4	SOLO	
042	Cold JX	1	POLY	106	Atlantis 2	4	POLY
043	Solo Vc 1 /	3	POLY	107	Taj Mahal	1	POLY
044	RichStrings2	4	POLY	108	X-hale	4	POLY
045	Techno Dream	3	POLY	109	Stacc.Heaven	4	POLY
046	StateXLChord	4	SOLO	110	Altamira	2	POLY
047	Delicate EP	2	POLY	111	Hit House	4	POLY
048	Bassic Needs	2	SOLO	112	Solo F.Horn1	1	POLY
049	Perky B	2	POLY	113	Celesta 1	1	POLY
050	SquareLead 2	2	POLY	114	ORBit Pad	2	POLY
051	Earth Blow	2	POLY	115	SessionBrass	4	POLY
052	BassMarimba1	2	POLY	116	Sugar Bell	4	POLY
053	Morning Lite	2	POLY	117	ChristmasFit	2	POLY
054	Raggatronic	4	POLY	118	Strobe Mode	4	POLY
055	Brass ff 1	2	POLY	119	Cave	4	POLY
056	Acc.de Paris	2	POLY	120	TenorExprss2	2	POLY
057	Oboe 1	2	POLY	121	Impact	4	POLY
058	Velo Power	4	POLY	122	X-Tronic Jam	4	SOLO
059	Vintage Call	4	POLY	123	WarmViolins2	4	POLY
060	Steel Away	3	POLY	124	Rain Forest	4	POLY
061	Spectrum Mod	4	POLY	125	Brass Ens 4	3	POLY
062	Raverborg	4	POLY	126	Perelandra	4	POLY
063	Poly Saws	4	POLY	127	Teknoperator	4	POLY
064	Adrenaline	4	POLY	128	Crowds	4	POLY

PR-A (Preset A Group)

No.	Name	Voice	Key Assign	No.	Name	Voice	Key Assign
001	64voicePiano	1	POLY	065	Dual Profs	3	POLY
002	Bright Piano	1	POLY	066	Saw Mass	4	POLY
003	Classique	2	POLY	067	Poly Split	4	POLY
004	Nice Piano	3	POLY	068	Poly Brass	3	POLY
005	Piano Thang	3	POLY	069	Stackoid	4	POLY
006	Power Grand	3	POLY	070	Poly Rock	4	POLY
007	House Piano	2	POLY	071	D-50 Stack	4	POLY
008	E.Grand	1	POLY	072	Fantasia JV	4	POLY
009	MIDled Grand	3	POLY	073	Jimmee Dee	4	POLY
010	Piano Blend	3	POLY	074	Heavenals	4	POLY
011	West Coast	4	POLY	075	Mallet Pad	4	POLY
012	PianoStrings	4	POLY	076	Huff N Stuff	3	POLY
013	Bs/Pno+Brs	4	POLY	077	Puff 1080	2	POLY
014	Waterhodes	2	POLY	078	BellVox 1080	4	POLY
015	S.A.E.P.	3	POLY	079	Fantasy Vox	4	POLY
016	SA Rhodes 1	4	POLY	080	Square Keys	2	POLY
017	SA Rhodes 2	2	POLY	081	Childlike	4	POLY
018	Stiky Rhodes	3	POLY	082	Music Box	3	POLY
019	Dig Rhodes	2	POLY	083	Toy Box	2	POLY
020	Nylon EPiano	4	POLY	084	Wave Bells	4	POLY
021	Nylon Rhodes	4	POLY	085	Tria Bells	4	POLY
022	Rhodes Mix	3	POLY	086	Beauty Bells	4	POLY
023	PsychoRhodes 2	POLY		087	Music Bells	2	POLY
024	Tremo Rhodes	4	POLY	088	Pretty Bells	2	POLY
025	MK-80 Rhodes	1	POLY	089	Pulse Key	3	POLY
026	MK-80 Phaser	1	POLY	090	Wide Tubular	4	POLY
027	Delicate EP	2	POLY	091	AmbienceVibe	4	POLY
028	Octa Rhodes1	4	POLY	092	Warm Vibes	2	POLY
029	Octa Rhodes2	4	POLY	093	Dyna Marimba	1	POLY
030	JV Rhodes+	4	POLY	094	Bass Marimba	4	POLY
031	EP+Mod Pad	4	POLY	095	Nomad Perc	3	POLY
032	Mr.Mellow	4	POLY	096	Ethno Metals	4	POLY
033	Comp Clav	1	POLY	097	Islands Mlt	4	POLY
034	Klavinet	4	POLY	098	Steelin Keys	3	POLY
035	Winger Clav	4	POLY	099	Steel Drums	1	POLY
036	Phaze Clav 1	2	POLY	100	Vocey Pizz	3	POLY
037	Phaze Clav 2	1	POLY	101	Sitar	2	POLY
038	Phuzz Clav	2	POLY	102	Drone Split	4	POLY
039	Chorus Clav	1	POLY	103	Ethnopluck	4	POLY
040	Claviduck	2	POLY	104	Jamisen	2	POLY
041	Velo-Rez Clv	1	POLY	105	Dulcimer	2	POLY
042	Clavicembalo	4	POLY	106	East Melody	2	POLY
043	Analog Clav1	1	POLY	107	MandolinTrem	4	POLY
044	Analog Clav2	1	POLY	108	Nylon Gtr	1	POLY
045	Metal Clav	3	POLY	109	Gtr Strings	3	POLY
046	Full Stops	2	POLY	110	Steel Away	3	POLY
047	Ballad B	3	POLY	111	Heavenly Gtr	4	POLY
048	Mellow Bars	4	POLY	112	12str Gtr 1	2	POLY
049	AugerMentive	3	POLY	113	12str Gtr 2	3	POLY
050	Perky B	2	POLY	114	Jz Gtr Hall	1	POLY
051	The Big Spin	3	POLY	115	LetterFrmPat	4	POLY
052	Gospel Spin	3	POLY	116	Jazz Scat	3	POLY
053	Roller Spin	3	POLY	117	Lounge Gig	3	POLY
054	Rocker Spin	3	POLY	118	JC Strat	1	POLY
055	Tone Wh.Solo	3	POLY	119	Twin Strats	3	POLY
056	Purple Spin	4	POLY	120	JV Strat	2	POLY
057	60's LeadORG	2	POLY	121	Syn Strat	2	POLY
058	Assalt Organ	3	POLY	122	Rotary Gtr	2	POLY
059	D-50 Organ	2	POLY	123	Muted Gtr	1	POLY
060	Cathedral	4	POLY	124	SwitchOnMute	2	POLY
061	Church Pipes	4	POLY	125	Power Trip	2	POLY
062	Poly Key	3	POLY	126	Crunch Split	4	POLY
063	Poly Saws	4	POLY	127	Rezodrive	2	SOLO
064	Poly Pulse	4	POLY	128	RockYurSocks	4	SOLO

Voice: number of voice

PR-B (Preset B Group)

No.	Name	Voice	Key Assign	No.	Name	Voice	Key Assign
001	Dist Gtr 1	3	POLY	065	Analog Seq	2	POLY
002	Dist Gtr 2	3	POLY	066	Impact Vox	4	POLY
003	R&R Chunk	4	POLY	067	TeknoSoloVox	2	POLY
004	Phripphuzz	1	SOLO	068	X-Mod Man	2	POLY
005	Grungeroni	3	POLY	069	Paz <==> Zap	1	SOLO
006	Black Widow	4	POLY	070	4 Hits 4 You	4	POLY
007	Velo-Wah Gtr	1	POLY	071	Impact	4	POLY
008	Mod-Wah Gtr	2	POLY	072	Phase Hit	3	POLY
009	Pick Bass	1	SOLO	073	Tekno Hit 1	2	POLY
010	Hip Bass	2	POLY	074	Tekno Hit 2	2	POLY
011	Perc.Bass	3	SOLO	075	Tekno Hit 3	4	POLY
012	Homey Bass	2	SOLO	076	Reverse Hit	3	POLY
013	Finger Bass	1	SOLO	077	SquareLead 1	3	POLY
014	Nylon Bass	2	POLY	078	SquareLead 2	2	POLY
015	Ac.Upright	1	SOLO	079	You and Luck	2	SOLO
016	Wet Fretls	1	SOLO	080	Belly Lead	4	POLY
017	Fretls Dry	2	POLY	081	WhistlinAtom	2	POLY
018	Slap Bass 1	2	POLY	082	Edye Boost	2	SOLO
019	Slap Bass 2	1	SOLO	083	MG Solo	4	SOLO
020	Slap Bass 3	1	SOLO	084	FXM Saw Lead	4	SOLO
021	Slap Bass 4	2	POLY	085	Sawteeth	3	SOLO
022	4 Pole Bass	1	SOLO	086	Smoothie	2	SOLO
023	Tick Bass	4	SOLO	087	MG Lead	2	SOLO
024	House Bass	3	SOLO	088	MG Interval	4	SOLO
025	Mondo Bass	3	SOLO	089	Pulse Lead 1	3	POLY
026	Clk AnalogBs	2	SOLO	090	Pulse Lead 2	4	SOLO
027	Bass In Face	2	POLY	091	Little Devil	4	SOLO
028	101 Bass	2	SOLO	092	Loud SynLead	4	SOLO
029	Noiz Bass	2	SOLO	093	Analog Lead	2	SOLO
030	Super Jup Bs	2	POLY	094	5th Lead	2	SOLO
031	Occitan Bass	3	POLY	095	Flute	2	POLY
032	Hugo Bass	4	SOLO	096	Piccolo	1	POLY
033	Multi Bass	2	POLY	097	VOX Flute	4	POLY
034	Moist Bass	2	SOLO	098	Air Lead	2	POLY
035	BritelowBass	4	SOLO	099	Pan Pipes	2	POLY
036	Untamed Bass	3	SOLO	100	Airplaaane	4	POLY
037	Rubber Bass	3	SOLO	101	Taj Mahal	1	POLY
038	Stereoww Bs	3	SOLO	102	Raya Shaku	3	POLY
039	Wonder Bass	3	SOLO	103	Oboe mf	1	POLY
040	Deep Bass	2	POLY	104	Oboe Express	2	POLY
041	Super JX Bs	2	SOLO	105	Clarinet mp	1	POLY
042	W<RED>-Bass	4	POLY	106	ClariExpress	2	POLY
043	HI-Ring Bass	3	POLY	107	Mitzva Split	4	POLY
044	Euro Bass	2	SOLO	108	ChamberWinds4	POLY	
045	SinusoidRave	1	SOLO	109	ChamberWoods3	POLY	
046	Alternative	2	SOLO	110	Film Orch	4	POLY
047	Acid Line	1	SOLO	111	Sop.Sax mf	2	POLY
048	Auto TB-303	3	SOLO	112	Alto Sax	3	POLY
049	Hihat Tekno	2	POLY	113	AltoLead Sax	3	POLY
050	Velo Tekno 1	3	SOLO	114	Tenor Sax	3	POLY
051	Raggatronic	4	POLY	115	Baritone Sax	3	POLY
052	Blade Racer	4	POLY	116	Take A Tenor	4	POLY
053	S&H Pad	1	POLY	117	Sax Section	4	POLY
054	Syncrosonix	3	POLY	118	Bigband Sax	4	POLY
055	Foiled Again	1	POLY	119	Harmonica	2	POLY
056	Alive	3	POLY	120	Harmo Blues	2	POLY
057	Velo Tekno 2	2	POLY	121	BluesHarp	1	POLY
058	Rezoid	4	POLY	122	Hillbillys	4	POLY
059	Raverborg	4	POLY	123	French Bags	4	POLY
060	Blow Hit	4	POLY	124	Majestic Tpt	1	SOLO
061	Hammer Bell	3	POLY	125	Voluntare	2	POLY
062	Seq Mallet	2	POLY	126	2Trumpets	2	POLY
063	Intentions	3	POLY	127	Tpt Sect	4	POLY
064	Pick It	3	POLY	128	Mute TP mod	4	POLY

PR-C (Preset C Group)

No.	Name	Voice	Key Assign	No.	Name	Voice	Key Assign
001	Harmon Mute	1	POLY	065	Harmonicum	2	POLY
002	Tp&Sax Sect	4	POLY	066	D-50 Heaven	2	POLY
003	Sax+Tp+Tb	3	POLY	067	Afro Horns	3	POLY
004	Brass Sect	4	POLY	068	Pop Pad	4	POLY
005	Trombone	1	POLY	069	Dreamesque	4	POLY
006	Hybrid Bones	4	POLY	070	Square Pad	4	POLY
007	Noble Horns	4	POLY	071	JP-8 Hollow	4	POLY
008	Massed Horns	3	POLY	072	JP-8Haunting	4	POLY
009	Horn Swell	4	POLY	073	Heirborne	4	POLY
010	Brass It!	4	POLY	074	Hush Pad	4	POLY
011	Brass Attack	3	POLY	075	Jet Pad 1	2	POLY
012	Archimede	3	POLY	076	Jet Pad 2	2	POLY
013	Rugby Horn	3	POLY	077	Phaze Pad	3	POLY
014	MKS-80 Brass	2	POLY	078	Phaze Str	4	POLY
015	True ANALOG	2	POLY	079	Jet Str Ens	2	POLY
016	Dark Vox	2	POLY	080	Pivotal Pad	4	POLY
017	RandomVowels4	POLY		081	3D Flanged	1	POLY
018	Angels Sing	2	POLY	082	Fantawine	4	POLY
019	Pvox Oooze	3	POLY	083	Glassy Pad	3	POLY
020	Longing...	3	POLY	084	Moving Glass	1	POLY
021	Arasian Morn	4	POLY	085	Glasswaves	3	POLY
022	Beauty Vox	3	POLY	086	Shiny Pad	4	POLY
023	Mary-AnneVox4	POLY		087	ShiftedGlass	2	POLY
024	Belltree Vox	4	POLY	088	Chime Pad	3	POLY
025	Vox Panner	2	POLY	089	Spin Pad	2	POLY
026	Spaced Voxx	4	POLY	090	Rotary Pad	4	POLY
027	Glass Voices	3	POLY	091	Dawn 2 Dusk	3	POLY
028	Tubular Vox	4	POLY	092	Aurora	4	POLY
029	Velo Voxx	2	POLY	093	Strobe Mode	4	POLY
030	Wavox	3	POLY	094	Albion	2	POLY
031	Doos	1	POLY	095	Running Pad	4	POLY
032	Synvox Comps	4	POLY	096	Stepped Pad	4	POLY
033	Vocal Oohz	3	POLY	097	Random Pad	4	POLY
034	LFO Vox	1	POLY	098	SoundtrkDANC	4	POLY
035	St.Strings	2	POLY	099	Flying Waltz	4	POLY
036	Warm Strings	4	POLY	100	Vanishing	1	POLY
037	Somber Str	4	POLY	101	5th Sweep	4	POLY
038	Marcato	2	POLY	102	Phazweep	4	POLY
039	Bright Str	2	POLY	103	Big BPF	4	POLY
040	String Ens	4	POLY	104	MG Sweep	4	POLY
041	TremoloStrng	2	POLY	105	CeremonyTimp	3	POLY
042	Chambers	3	POLY	106	Dyno Toms	4	POLY
043	ViolinCello	4	POLY	107	Sands ofTime	4	POLY
044	Symphonique	4	POLY	108	Inertia	4	POLY
045	Film Octaves	4	POLY	109	Vektogram	4	POLY
046	Film Layers	4	POLY	110	Crash Pad	4	POLY
047	Bass Pizz	4	POLY	111	Feedback VOX4	POLY	
048	Real Pizz	3	POLY	112	Cascade	1	POLY
049	Harp On It	3	POLY	113	Shattered	2	POLY
050	Harp	2	POLY	114	NextFrontier	2	POLY
051	JP-8 Str 1	2	POLY	115	Pure Tibet	1	POLY
052	JP-8 Str 2	3	POLY	116	Chime Wash	4	POLY
053	E-Motion Pad	4	POLY	117	Night Shade	4	POLY
054	JP-8 Str 3	4	POLY	118	Tortured	4	POLY
055	Vintage Orch	4	POLY	119	Dissimilate	4	POLY
056	JUNO Strings	3	POLY	120	Dunes	4	POLY
057	Gigantalog	4	POLY	121	Ocean Floor	1	POLY
058	PWM Strings	3	POLY	122	Cyber Space	3	POLY
059	Warmth	2	POLY	123	Biosphere	2	POLY
060	ORBit Pad	2	POLY	124	Variable Run	4	POLY
061	Deep Strings	2	POLY	125	Ice Hall	2	POLY
062	Pulsify	4	POLY	126	ComputerRoom	4	POLY
063	Pulse Pad	4	POLY	127	Inverted	4	POLY
064	Greek Power	4	POLY	128	Terminate	3	POLY

Voice: number of voice

Patch List

PR-D (GM Group)

No.	Name	Voice	Key Assign	No.	Name	Voice	Key Assign
001	Piano 1	2	POLY *1	065	Soprano Sax	1	POLY
002	Piano 2	2	POLY *2	066	Alto Sax	1	POLY
003	Piano 3	2	POLY	067	Tenor Sax	1	POLY *1
004	Honky-tonk	2	POLY	068	Baritone Sax	2	POLY
005	E.Piano 1	2	POLY	069	Oboe	1	POLY *2
006	E.Piano 2	4	POLY	070	English Horn	1	POLY *2
007	Harpsichord	1	POLY *2	071	Bassoon	2	POLY *2
008	Clav.	2	POLY	072	Clarinet	1	POLY
009	Celesta	1	POLY *2	073	Piccolo	1	POLY *2
010	Glockenspiel	2	POLY *2	074	Flute	1	POLY
011	Music Box	1	POLY	075	Recorder	2	POLY *2
012	Vibraphone	1	POLY	076	Pan Flute	2	POLY
013	Marimba	1	POLY *2	077	Bottle Blow	2	POLY
014	Xylophone	2	POLY *2	078	Shakuhachi	1	POLY
015	Tubular-bell	2	POLY *2	079	Whistle	1	POLY
016	Santur	2	POLY	080	Ocarina	2	POLY
017	Organ 1	1	POLY	081	Square Wave	2	POLY
018	Organ 2	1	POLY	082	Saw Wave	2	POLY
019	Organ 3	2	POLY	083	Syn.Calliope	2	POLY
020	Church Org.1	2	POLY	084	Chiffer Lead	2	POLY
021	Reed Organ	1	POLY	085	Charang	3	POLY
022	Accordion Fr	1	POLY *1	086	Solo Vox	2	POLY
023	Harmonica	1	POLY	087	5th Saw Wave	3	POLY
024	Bandoneon	2	POLY	088	Bass & Lead	2	POLY
025	Nylon-str.Gt	1	POLY *1	089	Fantasia	3	POLY
026	Steel-str.Gt	1	POLY	090	Warm Pad	2	POLY
027	Jazz Gt.	1	POLY	091	Polysynth	2	POLY
028	Clean Gt.	1	POLY *1	092	Space Voice	2	POLY
029	Muted Gt.	1	POLY	093	Bowed Glass	3	POLY
030	Overdrive Gt	1	POLY	094	Metal Pad	2	POLY
031	DistortionGt	1	POLY *1	095	Halo Pad	3	POLY
032	Gt.Harmonics	3	POLY	096	Sweep Pad	2	POLY
033	Acoustic Bs.	3	POLY	097	Ice Rain	2	POLY
034	Fingered Bs.	1	POLY	098	Soundtrack	2	POLY
035	Picked Bs.	1	POLY *1	099	Crystal	2	POLY
036	Fretless Bs.	1	POLY	100	Atmosphere	2	POLY
037	Slap Bass 1	1	POLY	101	Brightness	3	POLY
038	Slap Bass 2	2	POLY	102	Goblin	2	POLY
039	Synth Bass 1	1	POLY	103	Echo Drops	2	POLY
040	Synth Bass 2	1	POLY	104	Star Theme	2	POLY
041	Violin	1	POLY *2	105	Sitar	1	POLY
042	Viola	2	POLY *2	106	Banjo	1	POLY
043	Cello	2	POLY *2	107	Shamisen	2	POLY
044	Contrabass	2	POLY *2	108	Koto	1	POLY
045	Tremolo Str	1	POLY	109	Kalimba	1	POLY
046	PizzicatoStr	1	POLY *2	110	Bag Pipe	3	POLY
047	Harp	1	POLY *2	111	Fiddle	1	POLY
048	Timpani	2	POLY *2	112	Shanai	1	POLY
049	Strings	2	POLY	113	Tinkle Bell	4	POLY
050	Slow Strings	1	POLY	114	Agogo	1	POLY
051	Syn.Strings1	2	POLY	115	Steel Drums	1	POLY
052	Syn.Strings2	2	POLY	116	Woodblock	1	POLY
053	Choir Aahs	1	POLY *1	117	Taiko	4	POLY
054	Voice Oohs	1	POLY	118	Melo. Tom 1	2	POLY
055	SynVox	1	POLY	119	Synth Drum	2	POLY
056	OrchestraHit	2	POLY *2	120	Reverse Cym.	1	POLY *2
057	Trumpet	1	POLY *1	121	Gt.FretNoise	1	POLY
058	Trombone	2	POLY *2	122	Breath Noise	2	POLY
059	Tuba	2	POLY *2	123	Seashore	3	POLY
060	MutedTrumpet	1	POLY *2	124	Bird	4	POLY
061	French Horn	2	POLY *2	125	Telephone 1	1	POLY
062	Brass 1	1	POLY *2	126	Helicopter	2	POLY
063	Synth Brass1	1	POLY	127	Applause	4	POLY
064	Synth Brass2	2	POLY	128	Gun Shot	2	POLY

PR-E (Preset E Group)

No.	Name	Voice	Key Assign	No.	Name	Voice	Key Assign
001	Echo Piano	3	POLY	065	Civilization	3	POLY
002	Upright Pno	3	POLY	066	Mental Chord	4	SOLO
003	RD-1000	3	POLY	067	House Chord	4	SOLO
004	Player's EP	2	POLY	068	Sequalog	4	POLY
005	D-50 Rhodes	4	POLY	069	Booster Bips	2	POLY
006	Innocent EP	2	POLY	070	VintagePlunk	4	SOLO
007	Echo Rhodes	4	POLY	071	Plik-Plok	2	POLY
008	See-Thru EP	3	POLY	072	RingSequence	4	POLY
009	FM BellPiano	3	POLY	073	Cyber Swing	4	POLY
010	Ring E.Piano	4	POLY	074	Keep :-)	2	POLY
011	Soap Opera	1	POLY	075	Resojuice	2	SOLO
012	Dirty Organ	3	POLY	076	B'on d'moov!	3	POLY
013	Surf's Up!	2	POLY	077	Dist TB-303	2	SOLO
014	Organesque	3	POLY	078	Temple of JV	4	POLY
015	pp Harmonium	1	POLY	079	Planet Asia	4	POLY
016	PieceOfCheez	1	POLY	080	Afterlife	3	POLY
017	Harpsy Clav	2	POLY	081	Trancing Pad	2	POLY
018	Exotic Velo	4	POLY	082	Pulsatronic	3	POLY
019	Holiday Cheer	4	POLY	083	Cyber Dreams	3	POLY
020	Morning Lite	2	POLY	084	Warm Pipe	1	SOLO
021	Prefab Chime	3	POLY	085	Pure Pipe	2	POLY
022	Belfry Chime	3	POLY	086	SH-2000	2	SOLO
023	Stacc.Heaven	4	POLY	087	X..? Whistle	3	POLY
024	2.2 Bell Pad	4	POLY	088	Jay Vee Solo	3	POLY
025	Far East	4	POLY	089	Progresso Ld	4	SOLO
026	Wire Pad	3	POLY	090	Adrenaline	4	POLY
027	PhaseBlipper	2	POLY	091	Enlighten	4	POLY
028	Sweep Clav	3	POLY	092	Glass Blower	3	POLY
029	Glider	2	POLY	093	Earth Blow	2	POLY
030	Solo Steel	4	POLY	094	JX SqCarpet	2	POLY
031	DesertCrystl	4	POLY	095	Dimensional	2	POLY
032	Clear Guitar	3	POLY	096	Jupiterings	2	POLY
033	Solo Strat	3	POLY	097	Analog Drama	3	POLY
034	Feed Me!	4	POLY	098	Rich Dynapad	4	POLY
035	Tube Smoke	2	POLY	099	Silky Way	2	POLY
036	Creamy	2	POLY	100	Gluey Pad	3	POLY
037	Blusey OD	2	POLY	101	BandPass Mod2	POLY	POLY
038	Grindstone	2	POLY	102	Soundtraque	2	POLY
039	OD 5ths	3	POLY	103	Translucence	4	POLY
040	East Europe	2	POLY	104	Darkshine	4	POLY
041	Dulcitar	4	POLY	105	D'light	2	POLY
042	Atmos Harp	4	POLY	106	December Sky	4	POLY
043	Pilgrimage	4	POLY	107	Octapad	3	POLY
044	202 Rude Bs	2	SOLO	108	JUNO Power!	4	POLY
045	2pole Bass	2	SOLO	109	Spectrum Mod	4	POLY
046	4pole Bass	2	SOLO	110	Stringsheen	3	POLY
047	Phaser MC	2	POLY	111	GR500 TmpDly	2	POLY
048	Miniphaser	2	POLY	112	Mod DirtyWav	3	POLY
049	Acid TB	1	SOLO	113	Silicon Str	4	POLY
050	Full Orchest	4	POLY	114	D50FantaPerc	3	POLY
051	Str + Winds	4	POLY	115	Rotodreams	3	POLY
052	Flute 2080	2	POLY	116	Blue Notes	4	POLY
053	Scat Flute	2	POLY	117	RiversOfTime	4	POLY
054	Sax Choir	4	POLY	118	Phobos	2	POLY
055	Ballad Trump	4	POLY	119	2 0 8 0	4	POLY
056	Sm.Brass Grp	4	POLY	120	Unearthly	4	POLY
057	Royale	4	POLY	121	Glistening	4	POLY
058	Brass Mutes	2	POLY	122	Sci-Fi Str	3	POLY
059	Breathy Brs	3	POLY	123	Shadows	4	POLY
060	3 Osc Brass	3	POLY	124	Helium Queen	4	SOLO
061	P5 Polymod	2	POLY	125	Sci-Fi FX x4	1	POLY
062	Triumph Brs	3	POLY	126	Perky Noize	3	POLY
063	Techno Dream	3	POLY	127	Droplet	3	POLY
064	Organizer	3	POLY	128	Rain Forest	4	POLY

*1: Uses XP-A (Session) waves.

*2: Uses XP-B (Orchestral) waves.

Voice: number of voice

XP-A (WAVE EXPANSION A: Session)

No.	Name	Voice	No.	Name	Voice	No.	Name	Voice	No.	Name	Voice
001	St.Concert	4	065	Fr.Accord 2	2	129	Quixelate	4	193	Build-Up Syn	3
002	9ft.Grand 1	4	066	Troubadour	3	130	Trangoa Wave	2	194	Atlantis 2	4
003	9ft.Grand 2	4	067	SessionNylon	3	131	Spiked Cheez	3	195	Perelandra	4
004	Euro Classic	2	068	Solo Nylon 1	3	132	Glassy Cheez	3	196	Plutonium	4
005	St.Pno & Str	4	069	Solo Nylon 2	2	133	Super 808Cow	4	197	Nautilus	2
006	Compress Pno	1	070	Nylon & Str	4	134	Arpeggiatoid	4	198	Metal Dreams	2
007	LA Session	4	071	Nylon & Flt	3	135	Euro Hit 1	4	199	Glass Clouds	4
008	Water Piano	4	072	Nylon Chord	3	136	Euro Hit 2	2	200	Harmonicloud	4
009	Vibra Rhodes	3	073	Stratar	2	137	Rave Slice	1	201	Shining Veil	3
010	Stack Rhodes	4	074	Clean Tele	4	138	Str Torture	2	202	Ethereal JX	2
011	ArcoEnsemble	2	075	Nashville	1	139	Juno Harpsi	3	203	Striking 5th	4
012	Vienna Strgs	3	076	Super Trem	4	140	Big Mess Pad	4	204	Meow 5ths	2
013	Str Adagio	2	077	SpaghettiGtr	2	141	Harpsoir	4	205	Stepflanger	3
014	Oct Strings	3	078	Duanne'sTone	2	142	Echo Juno	3	206	Happy LFOs	4
015	Silky Filter	2	079	Big Hair Ld	2	143	Phazerave	2	207	Aero Insect	3
016	Soft Strings	2	080	Metal Solo	4	144	DanceStack 1	3	208	Beat Sweeper	2
017	SlowStr.Sect	2	081	Crunch Tone	1	145	DanceStack 2	4	209	Wormy Lead	3
018	GiantStrings	4	082	Overdriven	1	146	DanceStack 3	4	210	Atmo Lead	3
019	Str+Choir 1	4	083	Blues Tele	4	147	DanceStack 4	3	211	Caliolead	3
020	Str+Choir 2	4	084	Tube Double	2	148	DanceStack 5	4	212	Tweedles	2
021	Str+Choir 3	4	085	Neil's Rust	4	149	DanceStack 6	3	213	Raw PWM	2
022	Breathy Humz	2	086	Short Crunch	4	150	DanceStack 7	4	214	Voc Solo 5th	4
023	Dream Voices	2	087	X-Fade Metal	4	151	DanceStack 8	4	215	Dirty Lead	2
024	Mmmms	2	088	Velo Power	4	152	Eurotek Brs	4	216	Boostweeper1	2
025	Chorale	1	089	Phazy Chunk	4	153	Synergy Brs	4	217	Boostweeper2	2
026	Space Men	3	090	Reso Tele	1	154	PortaSynthex	3	218	B3 Filth	4
027	Choir Mm+Aah	4	091	Wah Wah BPM	4	155	Razor VCOs	4	219	Phazed Organ	3
028	Ivory Mist	4	092	Rock P.Bass1	1	156	Big PWM	2	220	VSw Vibrafon	3
029	Percussivox	4	093	Rock P.Bass2	2	157	Flutey Stack	2	221	SA Vibe	1
030	Mysterious	3	094	Rock P.Bass3	4	158	Wobbly 5th	4	222	Rich Vibes	2
031	Phase Mmhs	3	095	Big Jazz Bs	3	159	Tekno Square	3	223	SpaceGamelan	4
032	AmbientStory	4	096	BriteJazz Bs	1	160	Trance VoXxX	4	224	Toy Vibe	3
033	Venus	3	097	Ch.Jazz Bs	2	161	Random Rave	3	225	Analog Bomb	2
034	SessionBrass	4	098	Mellow Jz Bs	2	162	Raver Circus	4	226	Seashore 2	4
035	Port.Tpts	2	099	Mute E.Bs	1	163	Resorave	2	227	Creation	4
036	R&R Brass	3	100	Octabahn Bs	4	164	Flangomatic	2	228	Cyberjunkie	4
037	Echo Brass	4	101	Slobbery Bs	2	165	O-Zu-Nu	4	229	Sci-Fi Bells	3
038	E.Coast Brs	4	102	Phase Worm	2	166	Sub Divided	1	230	Shine on	1
039	Bop Soli	2	103	Euro Rave Bs	2	167	Ancient Sqr	2	231	DEMO Piano1	4
040	Soft Saxes	4	104	Pumpin' Bs	3	168	Fat Flange	2	232	DEMO Piano2	4
041	Orchestral	4	105	Tech NoBase	2	169	Phaze NRG	1	233	DEMO PnoVox	3
042	Octalog Hrn	2	106	Bad Acid Bs	2	170	Phase Vox	3	234	DEMO Str 1	2
043	Tpt Soloist	1	107	CheepEcho Bs	3	171	Systekno	4	235	DEMO Str 2	2
044	Legato Tpt	2	108	Manic Bs	4	172	On the move!	2	236	DEMO Str 3	2
045	Dyno Trumpet	2	109	JP6 Sqr Key	2	173	XP'ration	2	237	DEMO SynPuls	2
046	Ethno-Trumps	2	110	Square drops	1	174	Big Ensemble	4	238	DEMO 5thPad	4
047	Super Tenor	3	111	Celestial	3	175	Lazerette	3	239	DEMO Choir	2
048	TenorExpress	2	112	Heavenly Eko	4	176	Fazed String	4	240	DEMO Brass	1
049	T.Sax f	1	113	JD-800 Nomad	3	177	Combing Slow	3	241	DEMO Tenor	3
050	Legato Flute	2	114	Vibrolater	4	178	Jet Stack	4	242	DEMO Tpt	1
051	Touch Flute	2	115	MartianChime	4	179	Phazeslopad	4	243	DEMO Flute	2
052	NewAge Flute	1	116	Big Wet Blip	4	180	Rize Mass	3	244	DEMO Nylon	4
053	Flute inMist	2	117	Amazing Echo	4	181	Portent	2	245	DEMO PhaseGt	4
054	Hybrid Flute	2	118	DelaySession	4	182	DCO Sweeper	3	246	DEMO DistGt1	4
055	Flute & Cla	3	119	Deletex	4	183	Sweep Rain	4	247	DEMO DistGt2	3
056	ChristmasFlt	2	120	Tarla	3	184	Sweep Stack	3	248	DEMO Strat	3
057	Fifth Flute	2	121	Mahoroba	4	185	Big Vectors	4	249	DEMO SlapBs	2
058	Cosmic Flute	2	122	Eurotek Clav	2	186	Poly Swell	2	250	DEMO P.Bass	1
059	Acc.de Paris	2	123	Dope Resoclv	1	187	Alchemy	3	251	DEMO SynBs	2
060	Paris 50's	4	124	Tekno Juno	2	188	Soli-na	2	252	DEMO SynLead	4
061	Musette Ens	4	125	Buzzzzzzzzzz	2	189	90s Str Mach	4	253	DEMO Insect	4
062	Montmartre	2	126	Slop-a-rama	2	190	Ultra Cheez	2	254	DEMO Buzzzzzz	2
063	Sad Akordion	3	127	Isn't Pretty	3	191	Juno-60 Pad	3	255	DEMO Crowd	4
064	Fr.Accordion	1	128	Polywasp	1	192	Progressive	2			

Voice: number of voice

Patch List

XP-B (WAVE EXPANSION B: Orchestral)

No.	Name	Voice	No.	Name	Voice	No.	Name	Voice	No.	Name	Voice
001	Warm Violins	3	065	Solo Cb 1 /	3	129	F.Hrn Sect2/	2	193	ClasclPiano2	3
002	Slow Vlns 1	3	066	Solo Cb 2	2	130	F.Hrn Sect3	2	194	ClasclPiano3	2
003	Vlns+Vlas 1	4	067	Marcato Cb 1	1	131	F.Hrn Sect4	4	195	ClasclPiano4	2
004	VI Sect mono	2	068	Chamber Ens1	1	132	F.Hrn Sect5/	3	196	Harpsichord1	2
005	Arco Violins	4	069	Chamber Ens2	2	133	F.Hrn Sect6	2	197	Harpsichord2	3
006	Marcato Vls1	4	070	Vln+Vla Dble	2	134	F.Hrn Sect7	4	198	Harpsichord3	4
007	Vlns+Vlas 2	2	071	Vln+Vc Dbl1	2	135	F.Hrn Sect8	2	199	Harpsichord4	3
008	Agitato Vls1	4	072	Vla+Vc Dbl2	2	136	MuteHrn Sect	1	200	Celesta 1	1
009	Rosin Pad 1	2	073	Vla+Vc Dble	2	137	Horn+Wood 1	4	201	Celesta 2	2
010	Dry Mid-High	4	074	Pizzicato 1	3	138	Horn+Wood 2	4	202	Celesta 3	1
011	Natural Vlns	2	075	Mono Pizz	1	139	Horn+Wood 3	3	203	Glockenleste	2
012	Sad Vln Sect	2	076	Pizzicato 2	2	140	Wood Sect 1	3	204	Marimba	1
013	Marcato Vas	2	077	Room Pizz	1	141	Wood Sect 2	4	205	BassMarimba1	2
014	Arco Violas	2	078	Hall Pizz	4	142	Wood Sect 3	3	206	BassMarimba2	1
015	Thick Violas	2	079	Tight Pizz	3	143	Wood Sect 4	3	207	Vibe	1
016	Va Sect f	1	080	Short Pizz	2	144	2 Oboes	2	208	Xylophone 1	2
017	Va Small Sec	3	081	STR Marcato1	2	145	Oboe + Cla	2	209	Xylophone 2	3
018	Agitato Vas1	4	082	Oct Marcato	4	146	Flt + Piccl	2	210	Xylophone 3	1
019	Sad Violas	2	083	Lower Marc!!	4	147	Flute + Cla	2	211	Glocken 1	1
020	Fast Cellos1	4	084	Big Marc!	4	148	Bassoon+EHrn	3	212	Glocken 2	1
021	Vcs Legato 1	1	085	STR Spiccato	3	149	Hi Woodwinds	4	213	ChurchBells1	3
022	Marcato Vcs1	3	086	Fast Attacks	4	150	WoodwindSpl	2	214	ChurchBells2	4
023	Small Vc Sec	2	087	Flute	1	151	Multi Reed	1	215	ChurchBells3	3
024	Agitato Vcs1	4	088	Flute V-Sw	4	152	4Trombones	2	216	TubulaBells1	2
025	Small Cellos	1	089	Piccolo	1	153	Tb Sect 1	3	217	TubulaBells2	2
026	Sad CelloSec	2	090	Piccolo Flt	2	154	Tb + Tp	2	218	Big Tubulars	4
027	Cb Sect ff	4	091	Recorder	1	155	4Trumpets	4	219	Dawning	4
028	Wide Basses	2	092	Oboe 1	2	156	3 Trumpets	3	220	MalletStack1	4
029	mf Basses	1	093	Oboe 2	2	157	Brass ff 1	2	221	MalletStack2	3
030	Agitato Cbs1	4	094	Oboe 3	2	158	Brass ff 2	3	222	MalletStack3	4
031	Vcs+Cbs	2	095	Oboe 4	2	159	Brass ff 3	4	223	MalletStack4	4
032	2 Basses	2	096	Oboe 5	2	160	McArthur Brs	4	224	MalletStack5	4
033	Euro Strings	4	097	English Hrn1	1	161	Big Bones	4	225	MalletStack6	4
034	Rich Strings	4	098	English Hrn2	1	162	BassBoneSect	3	226	MalletStack7	4
035	Multi Strs 1	2	099	English Hrn3	1	163	Brass Swell1	3	227	Choir 1	3
036	VlsVasVcsCbs	4	100	Bassoon 1	1	164	Full Brs 1	4	228	Choir 2	1
037	Bright Strs	4	101	Bassoon 2	1	165	Brass Sect1/	4	229	Snare Drum	2
038	Classicl Str	3	102	Clarinet 1	1	166	Brass Ens 1	3	230	ConcertSNR1/	4
039	Full Strings	4	103	Clarinet 2	2	167	Brass Ens 2	3	231	ConcertSNR2/	3
040	Med Str Sec	2	104	Bs Clarinet1	2	168	Brass Ens 3	3	232	SNR Roll /	4
041	Small Strngs	1	105	Bs Clarinet2	2	169	Brass Ens 4	3	233	Concert BD1	3
042	Strings Arco	4	106	Trumpet 1	1	170	Brass Ens 5	3	234	Concert BD2/	3
043	Vivace Strs	4	107	Trumpet 2	3	171	Brass Ens 6	3	235	BD Roll /	3
044	Agitato STR1	4	108	Trumpet 3	2	172	Brass Ens 7	3	236	Timpani 1 /	2
045	LowSTR Attak	4	109	Flugelhorn 1	2	173	Brass Ens 8	3	237	Timpani 2 /	4
046	Bad Guy STR	3	110	Flugelhorn 2	1	174	Horn Strings	4	238	Timpani 3	4
047	Ominous	4	111	Cornet 1	1	175	Full Orch.1	2	239	Timpani 4 /	3
048	Lo Express	4	112	Cornet 2	2	176	Full Orch.2	4	240	Tam Tam	2
049	DramaStrings	4	113	Solo Tb 1	1	177	Full Orch.3	4	241	Gong	2
050	Solo Vln 1 /	4	114	Solo Tb 2	1	178	Full Orch.4	4	242	Piatti!!	2
051	Solo Vln 2	2	115	Solo Tb 3 /	4	179	Maj Hit 1	4	243	Sleigh Bells	1
052	Chorus Vln	2	116	Solo Tb 4 /	2	180	Min Hit 1	4	244	Slapstick /	3
053	Stereo Vln	3	117	Bs Tb 1	1	181	Dim Hit 1	4	245	Wind Chimes1	1
054	Agitato Vln1	2	118	Bs Tb 2 /	2	182	Major Stab!	4	246	Wind Chimes2	3
055	Solo Vla 1 /	3	119	Harmon Mute1	1	183	Maj Hit 2	4	247	Tambourine /	2
056	Solo Vla 2	2	120	Harmon Mute2	2	184	Min Hit 2	4	248	Castanets /	2
057	Chorus Viola	2	121	Tuba 1	2	185	Classical Gt	3	249	Rhythm Set	3
058	Stereo Viola	3	122	Tuba 2	2	186	Harp 1	1	250	Perc Hit 1	4
059	Agitato Vla	2	123	Solo F.Horn1	1	187	Harp 2	2	251	Perc Hit 2 /	4
060	Solo Vc 1 /	3	124	Solo F.Horn2	1	188	Plucked Harp	3	252	Perc Hit 3	3
061	Solo Vc 2	2	125	Sml F.Hrn sc	3	189	Harp StrumMj	4	253	Presenting!	4
062	Stereo Cello	3	126	Horn Sect 1/	4	190	Harp StrumMn	4	254	Presto!	4
063	Chorus Cello	2	127	F.Horn sc x4	1	191	Water Harp	3	255	Christmas!!!	3
064	Marcato Vc 1	1	128	Fr.Horn sfz	2	192	ClasclPiano1	2			

Voice: number of voice

XP-C (WAVE EXPANSION C: Techno Collection)

No.	Name	Voice	No.	Name	Voice	No.	Name	Voice	No.	Name	Voice
001	Teknoperator(132)	4	065	Jericho Bass	2	129	Euforia	3	193	Chordmaj7/5-	4
002	Transmission(144)	4	066	Slippy Bass	2	130	Labo-Feedbak	4	194	Planet EKNO	3
003	X-Tronic Jam(120)	4	067	Rise Bass	2	131	Banded Jupe	1	195	Optimum Rave	4
004	Dirt Jungle(160)	2	068	Cyber Bass	2	132	Killer Pad	1	196	Arpege Me	2
005	DJ Spinnin(151)	4	069	SH-2000 Bass	2	133	Mystic Pad	4	197	VTransformer	4
006	Zipper Beat(151)	4	070	FM Bass	1	134	D-Mention	4	198	Analog Attax	4
007	Tribal House(151)	3	071	Razor Bass	2	135	X-hale	4	199	Maxi Fuzzy !	2
008	Obsession(144)	4	072	SquelchyBass	2	136	Sirena	4	200	Only by FXM	3
009	Sonic Empire(144)	4	073	RaversBass	4	137	After's Pad	3	201	Hit & Run	4
010	Double Dutch(140)	4	074	Compu Bass	2	138	Warmer Pad	2	202	Photon Attak	4
011	E-tronicBoom(116)	3	075	Jump Bass	2	139	Phatt Pad	2	203	Predator	4
012	Chillout ==>(116)	4	076	VocoBass	2	140	OB Sweep Pad	3	204	Village Hit	4
013	MecaTrip-Hop(90)	4	077	Vocoder Menu	1	141	Murk Pad	4	205	Hardcore Hit	4
014	Hero Beat(90)	4	078	1.2.3.4. BPM	4	142	Dense Floor	4	206	Short Chord	4
015	Hit House(120)	4	079	TeknoMusic	3	143	SecretMelody	4	207	ShortCircuit	4
016	Voco Groove(122)	4	080	Retrocoder	2	144	Vaporish	4	208	SonofaPitch	4
017	Hell Fire(151)	4	081	u/i/e/o V/Sw	4	145	Vintage Revo	3	209	Flutish SQUR	4
018	Lo:BD Hi:HH(144)	2	082	Talk Box 1	3	146	Liquid Sky	4	210	FazzyCow 808	3
019	Detroit+Perc(132)	2	083	Talk Box 2	1	147	Exploration	3	211	Blurpy	3
020	Crossfader(120)	2	084	VT Vox	2	148	Drama Pad	4	212	Static Hit	3
021	Soft & Hard(120)	2	085	Artificial	4	149	Vapor Style	4	213	Hi Attack	3
022	Space Shake(130)	4	086	BariVoise	1	150	JP-6 Stack	1	214	TonalTension	4
023	Under Ether(85)	2	087	After D !	4	151	Obilator	1	215	Jungle Stabs	2
024	Confusion(147)	4	088	ARPsychea	4	152	Glamour	3	216	Buzz Machine	2
025	Amsterdamer(184)	2	089	Vintage Call	4	153	Medium Solo	3	217	Zapper	1
026	House that?(120)	4	090	HarmoChimer	2	154	Singing'Mini	1	218	Blip	1
027	Phrase Menu	1	091	Ring Bell	2	155	Analog Flute	1	219	Iron Hit	2
028	Cyber-Trance	3	092	260 & JUNO	3	156	SH-5 Bs/Lead	2	220	Headz Direct	1
029	Creator	3	093	260 MIDI	1	157	Classy Pulse	1	221	Scratchy Hit	2
030	Etherality	4	094	SquareKeys 2	1	158	Jupiter-6 Ld	2	222	Hit&IndsMenu	3
031	Unplugged	4	095	Pure Sine	1	159	Just Lovely	1	223	GTR FX Menu	1
032	Acid Melt	3	096	Ambient ORG	2	160	DJ Devil	1	224	GTR Power 1	1
033	Brain Waves	4	097	JX Planet	1	161	Simply June	1	225	GTR Power 2	1
034	1Shot Groove	1	098	Clavi-Club	2	162	Mr.Raw SAW	1	226	Snr Menu 1	3
035	FirstContact	2	099	Sweep Clav 2	3	163	Crispy Lead	4	227	Snr Menu 2	2
036	Ambient S/H	4	100	SquareTek	2	164	Dirty Lead 2	3	228	Kick Menu	2
037	Deep Machine	2	101	Retro Party	3	165	Disto Stack	4	229	Hi Hat Menu	4
038	Big Blue	2	102	Rave Nature	2	166	Velo Cheese	3	230	Perc Menu	4
039	TeeBee V/Sw	4	103	Alias Square	2	167	Noiz Mania	4	231	Tom&Cym Menu	2
040	303 Agressor	2	104	Dirty Stack	1	168	Power Mutes	2	232	Metal Dream	4
041	TB or not TB	3	105	Phenomena	4	169	V-Beep	1	233	System D	4
042	HiLo303ModSw	2	106	Music Hi	1	170	Freaky Fry	1	234	Mayday Ring	2
043	2Square Bass	2	107	Euro-Dance 1	3	171	SQ Formule	1	235	Industrial	4
044	303 HollowBS	2	108	Euro-Dance 2	3	172	DirtyOrgan 2	2	236	Tranceporter	3
045	303 Bass	2	109	Dance Stack	4	173	Oldies Organ	2	237	Acid Copter	1
046	TB Saw Bass	1	110	Raver Blade	4	174	Edgy Organ	4	238	Roll Over	4
047	303 Ow Bass	1	111	White Gloves	1	175	Juno Organ	2	239	Gimme aBreak	4
048	TB Square 1	2	112	Touchdown	4	176	Space Org X	3	240	RadicalAbuse	2
049	TB Square 2	2	113	Rave Station	2	177	Cabin Organ	2	241	Echodrome	1
050	TB Square 3	2	114	Time Warp	3	178	Dream Organ	3	242	Trance Chime	2
051	Solid Bass 1	2	115	Thin Rave	4	179	Club Organ	2	243	Altamira	2
052	Solid Bass 2	1	116	Igor Circus	3	180	Perc. Organ	2	244	Locko Motif	1
053	FM Tube Bass	3	117	Alpha Zone	4	181	Organ Stabs	2	245	SpaceFactory	2
054	Drum'n'Bass	3	118	Stars March	4	182	Techno Pizz	1	246	Get Busy	4
055	Sub Bass	1	119	JP Velo-Saw	2	183	Captain Pizz	4	247	Ayers Rock	4
056	Dirty Bass	2	120	Rich Teeth	4	184	Pizzatek	2	248	Altern Saw	1
057	Gate Me Buzz	1	121	After Saw	4	185	Sleepless	4	249	JP-6 Sync	1
058	Complex Bass	1	122	Saw Cocktail	3	186	Mega 5th 2	2	250	Cold JX	1
059	Bass Invader	2	123	Poly Message	2	187	Chord maj7th	4	251	Fancy Pad	1
060	Ovdrive Bass	1	124	Xpressive	4	188	Chord min7th	4	252	Tune Breath	2
061	Housy Bella	4	125	Earblower	3	189	5thDimension	4	253	OrchestraGTR	2
062	Bassic Needs	2	126	Cutting Edge	4	190	StateXLChord	4	254	Gtr Sweep	2
063	Raver Bass 1	2	127	Stalactica	4	191	Sixth Sense	4	255	Trilly	2
064	Raver Bass 2	2	128	LA Heaven	4	192	Garage Chord	4	256	Good Bye Spk	4

* The numbers in parenthesis following the Patch name represent the B.P.M. (tempo) when played at the C4 key.

* Note that the Release Time has been set to a fairly long value for some of the patches. As a result, if your sound generator has been set so "Patch Remain" is "ON," the release portion of a previously sounding patch may continue to be heard even after switching to a new

Voice: number of voice

■ B.P.M. CONVERSION TABLE

By changing the pitch, you can change the B.P.M. (tempo).

The B.P.M. used when sampling the original (Original B.P.M.) is reproduced by the C4 key when both "c.t." (Coarse Tune) and "f.t." (Fine Tune) are at "0."

If you want to obtain twice the tempo of the original B.P.M., either play the C5 key (key one octave above), or set "c.t." (Coarse Tune) to +12 and play the C4 key.

For specifics, refer to the separate B.P.M. Conversion Table.

How to Read the Table

● B.P.M. Conversion When Creating Patches

The Original B.P.M. is the B.P.M. obtained when the Waveform is played by the C4 key (when both Coarse and Fine Tune are at "0").

(Marked with in table.)

For example, to play a B.P.M. 116 Waveform at B.P.M. 120:

dst	key	c.t	f.t
116	C 4	00	00
120	C# 4	+01	-41

Method 1: Look up the "f.t." (Fine Tune) parameter in the table, and you will see that the setting for "f.t." should be -41 and that the C#4 key should be played.

Method 2: Look up the "c.t." (Coarse Tune) and "f.t." (Fine Tune) parameters in the table, and you will see that the setting for "c.t." should be +1, and that for "f.t." should be -41, and that the C4 key should be played.

So, as you can see from the above example, the settings you should make change depending on whether you want to play using the same key or not.

● B.P.M. Conversion When Creating Rhythm Sets

Given that the Original Pitch for the Rhythm Set is C4, you need to set

"c.t." (Coarse Tune) for the range C-1 through G9.

To play a Phrase Loop Waveform at the Original B.P.M., set "c.t." (Coarse Tune) to C4, and "f.t." (Fine Tune) to "0."

To change the B.P.M. for a Phrase Loop Waveform in a Rhythm Set, look up

"key" and "f.t." (Fine Tune) in the table, and make the necessary settings.

Original B.P.M.				116			
dst	key	c.t	f.t	dst	key	c.t	f.t
41	F# 2	-18	-01	141	D# 4	+03	+38
42	F# 2	-18	+41	142	E 4	+04	-50
43	G 2	-17	-18	143	E 4	+04	-38
44	G 2	-17	+22	144	E 4	+04	-26
45	G# 2	-16	-39	145	E 4	+04	-14
46	G# 2	-16	-01	146	E 4	+04	-02
47	G# 2	-16	+36	147	E 4	+04	+10
48	A 2	-15	-28	148	E 4	+04	+22
49	A 2	-15	+08	149	E 4	+04	+33
50	A 2	-15	+43	150	E 4	+04	+45
51	A# 2	-14	-23	151	F 4	+05	-43
52	A# 2	-14	+11	152	F 4	+05	-32
53	A# 2	-14	+44	153	F 4	+05	-21
54	B 2	-13	-24	154	F 4	+05	-09
55	B 2	-13	+08	155	F 4	+05	+02
56	B 2	-13	+39	156	F 4	+05	+13
57	C 3	-12	-30	157	F 4	+05	+24
58	C 3	-12	00	158	F 4	+05	+35
59	C 3	-12	+30	159	F 4	+05	+46
60	C# 3	-11	-41	160	F# 4	+06	-43
61	C# 3	-11	-13	161	F# 4	+06	-32
62	C# 3	-11	+15	162	F# 4	+06	-22
63	C# 3	-11	+43	163	F# 4	+06	-11
64	D 3	-10	-30	164	F# 4	+06	-01
65	D 3	-10	-03	165	F# 4	+06	+10
66	D 3	-10	+24	166	F# 4	+06	+20
67	D 3	-10	+50	167	F# 4	+06	+31
68	D# 3	-09	-25	168	F# 4	+06	+41
69	D# 3	-09	+01	169	G 4	+07	-49
70	D# 3	-09	+26	170	G 4	+07	-38
71	E 3	-08	-50	171	G 4	+07	-28
72	E 3	-08	-26	172	G 4	+07	-18
73	E 3	-08	-02	173	G 4	+07	-08
74	E 3	-08	+22	174	G 4	+07	+02
75	E 3	-08	+45	175	G 4	+07	+12
76	F 3	-07	-32	176	G 4	+07	+22
77	F 3	-07	-09	177	G 4	+07	+32
78	F 3	-07	+13	178	G 4	+07	+41
79	F 3	-07	+35	179	G# 4	+08	-49
80	F# 3	-06	-43	180	G# 4	+08	-39
81	F# 3	-06	-22	181	G# 4	+08	-30
82	F# 3	-06	-01	182	G# 4	+08	-20
83	F# 3	-06	+20	183	G# 4	+08	-11
84	F# 3	-06	+41	184	G# 4	+08	-01
85	G 3	-05	-38	185	G# 4	+08	+08
86	G 3	-05	-18	186	G# 4	+08	+17
87	G 3	-05	+02	187	G# 4	+08	+27
88	G 3	-05	+22	188	G# 4	+08	+36
89	G 3	-05	+41	189	G# 4	+08	+45
90	G# 3	-04	-39	190	A 4	+09	-46
91	G# 3	-04	-20	191	A 4	+09	-37
92	G# 3	-04	-01	192	A 4	+09	-28
93	G# 3	-04	+17	193	A 4	+09	-19
94	G# 3	-04	+36	194	A 4	+09	-10
95	A 3	-03	-46	195	A 4	+09	-01
96	A 3	-03	-28	196	A 4	+09	+08
97	A 3	-03	-10	197	A 4	+09	+17
98	A 3	-03	+08	198	A 4	+09	+26
99	A 3	-03	+26	199	A 4	+09	+34
100	A 3	-03	+43	200	A 4	+09	+43
101	A# 3	-02	-40	201	A# 4	+10	-48
102	A# 3	-02	-23	202	A# 4	+10	-40
103	A# 3	-02	-06	203	A# 4	+10	-31
104	A# 3	-02	+11	204	A# 4	+10	-23
105	A# 3	-02	+28	205	A# 4	+10	-14
106	A# 3	-02	+44	206	A# 4	+10	-06
107	B 3	-01	-40	207	A# 4	+10	+03
108	B 3	-01	-24	208	A# 4	+10	+11
109	B 3	-01	-08	209	A# 4	+10	+19
110	B 3	-01	+08	210	A# 4	+10	+28
111	B 3	-01	+24	211	A# 4	+10	+36
112	B 3	-01	+39	212	A# 4	+10	+44
113	C 4	00	-45	213	B 4	+11	-48
114	C 4	00	-30	214	B 4	+11	-40
115	C 4	00	-15	215	B 4	+11	-32
116	C 4	00	00	216	B 4	+11	-24
117	C 4	00	+15	217	B 4	+11	-16
118	C 4	00	+30	218	B 4	+11	-08
119	C 4	00	+44	219	B 4	+11	00
120	C# 4	+01	-41	220	B 4	+11	+08
121	C# 4	+01	-27	221	B 4	+11	+16
122	C# 4	+01	-13	222	B 4	+11	+24
123	C# 4	+01	+01	223	B 4	+11	+32
124	C# 4	+01	+15	224	B 4	+11	+39
125	C# 4	+01	+29	225	B 4	+11	+47
126	C# 4	+01	+43	226	C 5	+12	-45
127	D 4	+02	-43	227	C 5	+12	-38
128	D 4	+02	-30	228	C 5	+12	-30
129	D 4	+02	-16	229	C 5	+12	-23
130	D 4	+02	-03	230	C 5	+12	-15
131	D 4	+02	+11	231	C 5	+12	-07
132	D 4	+02	+24	232	C 5	+12	00
133	D 4	+02	+37	233	C 5	+12	+07
134	D 4	+02	+50	234	C 5	+12	+15
135	D# 4	+03	-37	235	C 5	+12	+22
136	D# 4	+03	-25	236	C 5	+12	+30
137	D# 4	+03	-12	237	C 5	+12	+37
138	D# 4	+03	+01	238	C 5	+12	+44
139	D# 4	+03	+13	239	C# 5	+13	-49
140	D# 4	+03	+26	240	C# 5	+13	-41

Original B.P.M. 120

dst	key	c.t	f.t	dst	key	c.t	f.t
41	F# 2	-19	+41	141	D# 4	+03	-21
42	F# 2	-18	-17	142	D# 4	+03	-09
43	F# 2	-18	+23	143	D# 4	+03	+04
44	G 2	-17	-37	144	D# 4	+03	+16
45	G 2	-17	+02	145	D# 4	+03	+28
46	G 2	-17	+40	146	D# 4	+03	+40
47	G# 2	-16	-23	147	E 4	+04	-49
48	G# 2	-16	+14	148	E 4	+04	-37
49	G# 2	-16	+49	149	E 4	+04	-25
50	A 2	-15	-16	150	E 4	+04	-14
51	A 2	-15	+19	151	E 4	+04	-02
52	A# 2	-14	-48	152	E 4	+04	+09
53	A# 2	-14	-15	153	E 4	+04	+21
54	A# 2	-14	+18	154	E 4	+04	+32
55	A# 2	-14	+49	155	E 4	+04	+43
56	B 2	-13	-19	156	F 4	+05	-46
57	B 2	-13	+11	157	F 4	+05	-35
58	B 2	-13	+41	158	F 4	+05	-24
59	C 3	-12	-29	159	F 4	+05	-13
60	C 3	-12	00	160	F 4	+05	-02
61	C 3	-12	+29	161	F 4	+05	+09
62	C# 3	-11	-43	162	F 4	+05	+20
63	C# 3	-11	-16	163	F 4	+05	+30
64	C# 3	-11	+12	164	F 4	+05	+41
65	C# 3	-11	+39	165	F# 4	+06	-49
66	D 3	-10	-35	166	F# 4	+06	-38
67	D 3	-10	-09	167	F# 4	+06	-28
68	D 3	-10	+17	168	F# 4	+06	-17
69	D 3	-10	+42	169	F# 4	+06	-07
70	D# 3	-09	-33	170	F# 4	+06	+03
71	D# 3	-09	-09	171	F# 4	+06	+13
72	D# 3	-09	+16	172	F# 4	+06	+23
73	D# 3	-09	+40	173	F# 4	+06	+33
74	E 3	-08	-37	174	F# 4	+06	+43
75	E 3	-08	-14	175	G 4	+07	-47
76	E 3	-08	+09	176	G 4	+07	-37
77	E 3	-08	+32	177	G 4	+07	-27
78	F 3	-07	-46	178	G 4	+07	-17
79	F 3	-07	-24	179	G 4	+07	-08
80	F 3	-07	-02	180	G 4	+07	+02
81	F 3	-07	+20	181	G 4	+07	+12
82	F 3	-07	+41	182	G 4	+07	+21
83	F# 3	-06	-38	183	G 4	+07	+31
84	F# 3	-06	-17	184	G 4	+07	+40
85	F# 3	-06	+03	185	G 4	+07	+49
86	F# 3	-06	+23	186	G# 4	+08	-41
87	F# 3	-06	+43	187	G# 4	+08	-32
88	G 3	-05	-37	188	G# 4	+08	-23
89	G 3	-05	-17	189	G# 4	+08	-14
90	G 3	-05	+02	190	G# 4	+08	-04
91	G 3	-05	+21	191	G# 4	+08	+05
92	G 3	-05	+40	192	G# 4	+08	+14
93	G# 3	-04	-41	193	G# 4	+08	+23
94	G# 3	-04	-23	194	G# 4	+08	+32
95	G# 3	-04	-04	195	G# 4	+08	+41
96	G# 3	-04	+14	196	G# 4	+08	+49
97	G# 3	-04	+32	197	A 4	+09	-42
98	G# 3	-04	+49	198	A 4	+09	-33
99	A 3	-03	-33	199	A 4	+09	-24
100	A 3	-03	-16	200	A 4	+09	-16
101	A 3	-03	+02	201	A 4	+09	-07
102	A 3	-03	+19	202	A 4	+09	+02
103	A 3	-03	+36	203	A 4	+09	+10
104	A# 3	-02	-48	204	A 4	+09	+19
105	A# 3	-02	-31	205	A 4	+09	+27
106	A# 3	-02	-15	206	A 4	+09	+36
107	A# 3	-02	+01	207	A 4	+09	+44
108	A# 3	-02	+18	208	A# 4	+10	-48
109	A# 3	-02	+34	209	A# 4	+10	-39
110	A# 3	-02	+49	210	A# 4	+10	-31
111	B 3	-01	-35	211	A# 4	+10	-23
112	B 3	-01	-19	212	A# 4	+10	-15
113	B 3	-01	-04	213	A# 4	+10	-07
114	B 3	-01	+11	214	A# 4	+10	+01
115	B 3	-01	+26	215	A# 4	+10	+10
116	B 3	-01	+41	216	A# 4	+10	+18
117	C 4	00	-44	217	A# 4	+10	+26
118	C 4	00	-29	218	A# 4	+10	+34
119	C 4	00	-14	219	A# 4	+10	+41
120	C 4	00	00	220	A# 4	+10	+49
121	C 4	00	+14	221	B 4	+11	-43
122	C 4	00	+29	222	B 4	+11	-35
123	C 4	00	+43	223	B 4	+11	-27
124	C# 4	+01	-43	224	B 4	+11	-19
125	C# 4	+01	-29	225	B 4	+11	-12
126	C# 4	+01	-16	226	B 4	+11	-04
127	C# 4	+01	-02	227	B 4	+11	+04
128	C# 4	+01	+12	228	B 4	+11	+11
129	C# 4	+01	+25	229	B 4	+11	+19
130	C# 4	+01	+39	230	B 4	+11	+26
131	D 4	+02	-48	231	B 4	+11	+34
132	D 4	+02	-35	232	B 4	+11	+41
133	D 4	+02	-22	233	B 4	+11	+49
134	D 4	+02	-09	234	C 5	+12	-44
135	D 4	+02	+04	235	C 5	+12	-36
136	D 4	+02	+17	236	C 5	+12	-29
137	D 4	+02	+29	237	C 5	+12	-22
138	D 4	+02	+42	238	C 5	+12	-14
139	D# 4	+03	-46	239	C 5	+12	-07
140	D# 4	+03	-33	240	C 5	+12	00

Original B.P.M. 132

dst	key	c.t	f.t	dst	key	c.t	f.t
41	E 2	-20	-24	141	C# 4	+01	+14
42	E 2	-20	+18	142	C# 4	+01	+26
43	F 2	-19	-42	143	C# 4	+01	+39
44	F 2	-19	-02	144	D 4	+02	-49
45	F 2	-19	+37	145	D 4	+02	-37
46	F# 2	-18	-25	146	D 4	+02	-25
47	F# 2	-18	+12	147	D 4	+02	-14
48	F# 2	-18	+49	148	D 4	+02	-02
49	G 2	-17	-16	149	D 4	+02	+10
50	G 2	-17	+19	150	D 4	+02	+21
51	G# 2	-16	-46	151	D 4	+02	+33
52	G# 2	-16	-13	152	D 4	+02	+44
53	G# 2	-16	+20	153	D# 4	+03	-44
54	A 2	-15	-47	154	D# 4	+03	-33
55	A 2	-15	-16	155	D# 4	+03	-22
56	A 2	-15	+16	156	D# 4	+03	-11
57	A 2	-15	+46	157	D# 4	+03	00
58	A# 2	-14	-24	158	D# 4	+03	+11
59	A# 2	-14	+06	159	D# 4	+03	+22
60	A# 2	-14	+35	160	D# 4	+03	+33
61	B 2	-13	-36	161	D# 4	+03	+44
62	B 2	-13	-08	162	E 4	+04	-45
63	B 2	-13	+19	163	E 4	+04	-35
64	B 2	-13	+47	164	E 4	+04	-24
65	C 3	-12	-26	165	E 4	+04	-14
66	C 3	-12	00	166	E 4	+04	-03
67	C 3	-12	+26	167	E 4	+04	+07
68	C# 3	-11	-48	168	E 4	+04	+18
69	C# 3	-11	-23	169	E 4	+04	+28
70	C# 3	-11	+02	170	E 4	+04	+38
71	C# 3	-11	+26	171	E 4	+04	+48
72	D 3	-10	-49	172	F 4	+05	-42
73	D 3	-10	-25	173	F 4	+05	-32
74	D 3	-10	-02	174	F 4	+05	-22
75	D 3	-10	+21	175	F 4	+05	-12
76	D 3	-10	+44	176	F 4	+05	-02
77	D# 3	-09	-33	177	F 4	+05	+08
78	D# 3	-09	-11	178	F 4	+05	+18
79	D# 3	-09	+11	179	F 4	+05	+27
80	D# 3	-09	+33	180	F 4	+05	+37
81	E 3	-08	-45	181	F 4	+05	+47
82	E 3	-08	-24	182	F# 4	+06	-44
83	E 3	-08	-03	183	F# 4	+06	-34
84	E 3	-08	+18	184	F# 4	+06	-25
85	E 3	-08	+38	185	F# 4	+06	-16
86	F 3	-07	-42	186	F# 4	+06	-06
87	F 3	-07	-22	187	F# 4	+06	+03
88	F 3	-07	-02	188	F# 4	+06	+12
89	F 3	-07	+18	189	F# 4	+06	+21
90	F 3	-07	+37	190	F# 4	+06	+31
91	F# 3	-06	-44	191	F# 4	+06	+40
92	F# 3	-06	-25	192	F# 4	+06	+49
93	F# 3	-06	-06	193	G 4	+07	-42
94	F# 3	-06	+12	194	G 4	+07	-33
95	F# 3	-06	+31	195	G 4	+07	-24
96	F# 3	-06	+49	196	G 4	+07	-16
97	G 3	-05	-33	197	G 4	+07	-07
98	G 3	-05	-16	198	G 4	+07	+02
99	G 3	-05	+02	199	G 4	+07	+11
100	G 3	-05	+19	200	G 4	+07	+19
101	G 3	-05	+37	201	G 4	+07	+28
102	G# 3	-04	-46	202	G 4	+07	+37
103	G# 3	-04	-29	203	G 4	+07	+45
104	G# 3	-04	-13	204	G# 4	+08	-46
105	G# 3	-04	+04	205	G# 4	+08	-38
106	G# 3	-04	+20	206	G# 4	+08	-29
107	G# 3	-04	+36	207	G# 4	+08	-21
108	A 3	-03	-47	208	G# 4	+08	-13
109	A 3	-03	-31	209	G# 4	+08	-04
110	A 3	-03	-16	210	G# 4	+08	+04
111	A 3	-03	00	211	G# 4	+08	+12
112	A 3	-03	+16	212	G# 4	+08	+20
113	A 3	-03	+31	213	G# 4	+08	+28
114	A 3	-03	+46	214	G# 4	+08	+36
115	A# 3	-02	-39	215	G# 4	+08	+45
116	A# 3	-02	-24	216	A 4	+09	-47
117	A# 3	-02	-09	217	A 4	+09	-39
118	A# 3	-02	+06	218	A 4	+09	-31
119	A# 3	-02	+21	219	A 4	+09	-24
120	A# 3	-02	+35	220	A 4	+09	-16
121	A# 3	-02	+49	221	A 4	+09	-08
122	B 3	-01	-36	222	A 4	+09	00
123	B 3	-01	-22	223	A 4	+09	+08
124	B 3	-01	-08	224	A 4	+09	+16
125	B 3	-01	+06	225	A 4	+09	+23
126	B 3	-01	+19	226	A 4	+09	+31
127	B 3	-01	+33	227	A 4	+09	+39
128	B 3	-01	+47	228	A 4	+09	+46
129	C 4	00	-40	229	A# 4	+10	-46
130	C 4	00	-26	230	A# 4	+10	-39
131	C 4	00	-13	231	A# 4	+10	

Patch List

Original B.P.M. 144

dst	key	c.t	f.t	dst	key	c.t	f.t
41	D 2	-22	+25	141	C 4	00	-36
42	D# 2	-21	-33	142	C 4	00	-24
43	D# 2	-21	+08	143	C 4	00	-12
44	D# 2	21	+47	144	C 4	00	00
45	E 2	-20	-14	145	C 4	00	+12
46	E 2	-20	+24	146	C 4	00	+24
47	F 2	-19	-38	147	C 4	00	+36
48	F 2	-19	-02	148	C 4	00	+47
49	F 2	-19	+34	149	C# 4	+01	-41
50	F# 2	-18	-31	150	C# 4	+01	-29
51	F# 2	-18	+03	151	C# 4	+01	-18
52	F# 2	-18	+37	152	C# 4	+01	-06
53	G 2	-17	-30	153	C# 4	+01	+05
54	G 2	-17	+02	154	C# 4	+01	+16
55	G 2	-17	+34	155	C# 4	+01	+27
56	G# 2	-16	-35	156	C# 4	+01	+39
57	G# 2	-16	-04	157	C# 4	+01	+50
58	G# 2	-16	+26	158	D 4	+02	-39
59	A 2	-15	-45	159	D 4	+02	-28
60	A 2	-15	-16	160	D 4	+02	-18
61	A 2	-15	+13	161	D 4	+02	-07
62	A 2	-15	+41	162	D 4	+02	+04
63	A# 2	-14	-31	163	D 4	+02	+15
64	A# 2	-14	-04	164	D 4	+02	+25
65	A# 2	-14	+23	165	D 4	+02	+36
66	A# 2	-14	+49	166	D 4	+02	+46
67	B 2	-13	-25	167	D# 4	+03	-43
68	B 2	-13	+01	168	D# 4	+03	-33
69	B 2	-13	+26	169	D# 4	+03	-23
70	C 3	-12	-49	170	D# 4	+03	-13
71	C 3	-12	-24	171	D# 4	+03	-02
72	C 3	-12	00	172	D# 4	+03	+08
73	C 3	-12	+24	173	D# 4	+03	+18
74	C 3	-12	+47	174	D# 4	+03	+28
75	C# 3	-11	-29	175	D# 4	+03	+38
76	C# 3	-11	-06	176	D# 4	+03	+47
77	C# 3	-11	+16	177	E 4	+04	-43
78	C# 3	-11	+39	178	E 4	+04	-33
79	D 3	-10	-39	179	E 4	+04	-23
80	D 3	-10	-18	180	E 4	+04	-14
81	D 3	-10	+04	181	E 4	+04	-04
82	D 3	-10	+25	182	E 4	+04	+05
83	D 3	-10	+46	183	E 4	+04	+15
84	D# 3	-09	-33	184	E 4	+04	+24
85	D# 3	-09	-13	185	E 4	+04	+34
86	D# 3	-09	+08	186	E 4	+04	+43
87	D# 3	-09	+28	187	F 4	+05	-48
88	D# 3	-09	+47	188	F 4	+05	-38
89	E 3	-08	-33	189	F 4	+05	-29
90	E 3	-08	-14	190	F 4	+05	-20
91	E 3	-08	+05	191	F 4	+05	-11
92	E 3	-08	+24	192	F 4	+05	-02
93	E 3	-08	+43	193	F 4	+05	+07
94	F 3	-07	-38	194	F 4	+05	+16
95	F 3	-07	-20	195	F 4	+05	+25
96	F 3	-07	-02	196	F 4	+05	+34
97	F 3	-07	+16	197	F 4	+05	+43
98	F 3	-07	+34	198	F# 4	+06	-49
99	F# 3	-06	-49	199	F# 4	+06	-40
100	F# 3	-06	-31	200	F# 4	+06	-31
101	F# 3	-06	-14	201	F# 4	+06	-23
102	F# 3	-06	+03	202	F# 4	+06	-14
103	F# 3	-06	+20	203	F# 4	+06	-06
104	F# 3	-06	+37	204	F# 4	+06	+03
105	G 3	-05	-47	205	F# 4	+06	+11
106	G 3	-05	-30	206	F# 4	+06	+20
107	G 3	-05	-14	207	F# 4	+06	+28
108	G 3	-05	+02	208	F# 4	+06	+37
109	G 3	-05	+18	209	F# 4	+06	+45
110	G 3	-05	+34	210	G 4	+07	-47
111	G 3	-05	+49	211	G 4	+07	-39
112	G# 3	-04	-35	212	G 4	+07	-30
113	G# 3	-04	-20	213	G 4	+07	-22
114	G# 3	-04	-04	214	G 4	+07	-14
115	G# 3	-04	+11	215	G 4	+07	-06
116	G# 3	-04	+26	216	G 4	+07	+02
117	G# 3	-04	+41	217	G 4	+07	+10
118	A 3	-03	-45	218	G 4	+07	+18
119	A 3	-03	-30	219	G 4	+07	+26
120	A 3	-03	-16	220	G 4	+07	+34
121	A 3	-03	-01	221	G 4	+07	+42
122	A 3	-03	+13	222	G 4	+07	+49
123	A 3	-03	+27	223	G# 4	+08	-43
124	A 3	-03	+41	224	G# 4	+08	-35
125	A# 3	-02	-45	225	G# 4	+08	-27
126	A# 3	-02	-31	226	G# 4	+08	-20
127	A# 3	-02	-17	227	G# 4	+08	-12
128	A# 3	-02	-04	228	G# 4	+08	-04
129	A# 3	-02	+10	229	G# 4	+08	+03
130	A# 3	-02	+23	230	G# 4	+08	+11
131	A# 3	-02	+36	231	G# 4	+08	+18
132	A# 3	-02	+49	232	G# 4	+08	+26
133	B 3	-01	-38	233	G# 4	+08	+33
134	B 3	-01	-25	234	G# 4	+08	+41
135	B 3	-01	-12	235	G# 4	+08	+48
136	B 3	-01	+01	236	A 4	+09	-45
137	B 3	-01	+14	237	A 4	+09	-37
138	B 3	-01	+26	238	A 4	+09	-30
139	B 3	-01	+39	239	A 4	+09	-23
140	C 4	00	-49	240	A 4	+09	-16

Original B.P.M. 160

dst	key	c.t	f.t	dst	key	c.t	f.t
41	C 2	-24	+43	141	A# 3	-02	-19
42	C# 2	-23	-16	142	A# 3	-02	-07
43	C# 2	-23	+25	143	A# 3	-02	+06
44	D 2	-22	-35	144	A# 3	-02	+18
45	D 2	-22	+04	145	A# 3	-02	+30
46	D 2	-22	+42	146	A# 3	-02	+41
47	D# 2	-21	-21	147	B 3	-01	-47
48	D# 2	-21	+16	148	B 3	-01	-35
49	E 2	-20	-49	149	B 3	-01	-23
50	E 2	-20	-14	150	B 3	-01	-12
51	E 2	-20	+21	151	B 3	-01	00
52	F 2	-19	-46	152	B 3	-01	+11
53	F 2	-19	-13	153	B 3	-01	+23
54	F 2	-19	+20	154	B 3	-01	+34
55	F# 2	-18	-49	155	B 3	-01	+45
56	F# 2	-18	-17	156	C 4	00	-44
57	F# 2	-18	+13	157	C 4	00	-33
58	F# 2	-18	+43	158	C 4	00	-22
59	G 2	-17	-27	159	C 4	00	-11
60	G 2	-17	+02	160	C 4	00	00
61	G 2	-17	+31	161	C 4	00	+11
62	G# 2	-16	-41	162	C 4	00	+22
63	G# 2	-16	-14	163	C 4	00	+32
64	G# 2	-16	+14	164	C 4	00	+43
65	G# 2	-16	+41	165	C# 4	+01	-47
66	A 2	-15	-33	166	C# 4	+01	-36
67	A 2	-15	-07	167	C# 4	+01	-26
68	A 2	-15	+19	168	C# 4	+01	-16
69	A 2	-15	+44	169	C# 4	+01	-05
70	A# 2	-14	-31	170	C# 4	+01	+05
71	A# 2	-14	-07	171	C# 4	+01	+15
72	A# 2	-14	+18	172	C# 4	+01	+25
73	A# 2	-14	+41	173	C# 4	+01	+35
74	B 2	-13	-35	174	C# 4	+01	+45
75	B 2	-13	-12	175	D 4	+02	-45
76	B 2	-13	+11	176	D 4	+02	-35
77	B 2	-13	+34	177	D 4	+02	-25
78	C 3	-12	-44	178	D 4	+02	-15
79	C 3	-12	-22	179	D 4	+02	-06
80	C 3	-12	00	180	D 4	+02	+04
81	C 3	-12	+22	181	D 4	+02	+14
82	C 3	-12	+43	182	D 4	+02	+23
83	C# 3	-11	-36	183	D 4	+02	+33
84	C# 3	-11	-16	184	D 4	+02	+42
85	C# 3	-11	+05	185	D# 4	+03	-49
86	C# 3	-11	+25	186	D# 4	+03	-39
87	C# 3	-11	+45	187	D# 4	+03	-30
88	D 3	-10	-35	188	D# 4	+03	-21
89	D 3	-10	-15	189	D# 4	+03	-12
90	D 3	-10	+04	190	D# 4	+03	-02
91	D 3	-10	+23	191	D# 4	+03	+07
92	D 3	-10	+42	192	D# 4	+03	+16
93	D# 3	-09	-39	193	D# 4	+03	+25
94	D# 3	-09	-21	194	D# 4	+03	+34
95	D# 3	-09	-02	195	D# 4	+03	+42
96	D# 3	-09	+16	196	E 4	+04	-49
97	D# 3	-09	+34	197	E 4	+04	-40
98	E 3	-08	-49	198	E 4	+04	-31
99	E 3	-08	-31	199	E 4	+04	-22
100	E 3	-08	-14	200	E 4	+04	-14
101	E 3	-08	+04	201	E 4	+04	-05
102	E 3	-08	+21	202	E 4	+04	+04
103	E 3	-08	+37	203	E 4	+04	+12
104	F 3	-07	-46	204	E 4	+04	+21
105	F 3	-07	-29	205	E 4	+04	+29
106	F 3	-07	-13	206	E 4	+04	+37
107	F 3	-07	+03	207	E 4	+04	+46
108	F 3	-07	+20	208	F 4	+05	-46
109	F 3	-07	+36	209	F 4	+05	-37
110	F# 3	-06	-49	210	F 4	+05	-29
111	F# 3	-06	-33	211	F 4	+05	-21
112	F# 3	-06	-17	212	F 4	+05	-13
113	F# 3	-06	-02	213	F 4	+05	-05
114	F# 3	-06	+13	214	F 4	+05	+03
115	F# 3	-06	+28	215	F 4	+05	+12
116	F# 3	-06	+43	216	F 4	+05	+20
117	G 3	-05	-42	217	F 4	+05	+28
118	G 3	-05	-27	218	F 4	+05	+36
119	G 3	-05	-13	219	F 4	+05	+43
120	G 3	-05	+02	220	F# 4	+06	-49
121	G 3	-05	+16	221	F# 4	+06	-41
122	G 3	-05	+31	222	F# 4	+06	-33
123	G 3	-05	+45	223	F# 4	+06	-25
124	G# 3	-04	-41	224	F# 4	+06	-17
125	G# 3	-04	-27	225	F# 4	+06	-10
126	G# 3	-04	-14	226	F# 4	+06	-02
127	G# 3	-04	00	227	F# 4	+06	+06
128	G# 3	-04	+14	228	F# 4	+06	+13
129	G# 3	-04	+27	229	F# 4	+06	+21
130	G# 3	-04	+41	230	F# 4	+06	

Rhythm Set List

	USER (User)		PR-A (Preset A Group)		PR-B (Preset B Group)	
	001	002	001	002	001	002
Note No.	HouseDrumSet 1	JazzDrumSet1	PopDrumSet 1	PopDrumSet 2	PowerDrumSet	RaveDrumSet
C2 35	Scratch 1	Hybrid Kick2	Verb Kick	Hybrid Kick1	Verb Kick	808 Kick
36	808 SN	Hybrid Kick1	Hybrid Kick1	Round Kick	Round Kick	Round Kick
37	Dry Stick	Side Stick	Side Stick	Dry Stick	Dry Stick	Side Stick
38	808 SN	Ballad SN	Natural SN2	Piccolo SN	Piccolo SN	808 SN
39	808 Claps	Brush Slap	808 Claps	Hand Claps	808 Claps	808 Claps
40	808 SN	Brush Swish	SN Roll	Piccolo SN	Natural SN2	808 SN
41	808 Kick	Verb Tom Lo	Verb Tom Lo	Verb Tom Lo	Verb Tom Lo	808 Kick
42	606 HiHat Cl	Cl HiHat 1	Cl HiHat 1	Cl HiHat 1	Cl HiHat 1	606 HiHat Cl
43	808 SN	Verb Tom Lo	Verb Tom Lo	Verb Tom Lo	Verb Tom Lo	Tekno Hit
44	606 HiHat Cl	Pedal HiHat	Cl HiHat 2	Cl HiHat 2	Pedal HiHat	606 HiHat Cl
45	808 Kick	Verb Tom Hi	Verb Tom Hi	Verb Tom Hi	Verb Tom Lo	808 Kick
46	606 HiHat Op	Op HiHat	Op HiHat	Op HiHat	Op HiHat	606 HiHat Op
47	808 SN	Verb Tom Hi	Verb Tom Hi	Verb Tom Hi	Verb Tom Lo	Tekno Hit
C3 48	808 Kick	Verb Tom Hi	Verb Tom Hi	Verb Tom Hi	Verb Tom Hi	808 Kick
49	Crash 1	Crash 1	Crash 1	Crash 1	Crash 1	Crash 1
50	808 SN	Verb Tom Hi	Verb Tom Hi	Verb Tom Hi	Verb Tom Hi	Tekno Hit
51	Ride 2	Ride 2	Ride 2	Ride 1	Ride 1	Voice Breath
52	REV Crash 1	China Cym	China Cym	China Cym	China Cym	MC500 Beep 1
53	Ride Bell 1	Ride Bell 1	Ride Bell 1	Ride Bell 1	Ride Bell 1	MC500 Beep 2
54	Tambourine	Tambourine	Tambourine	Tambourine	Tambourine	R8 Click
55	Crash 1	Crash 1	Crash 1	Crash 1	Crash 1	Pizz
56	Cowbell 1	Cowbell 1	Cowbell 1	Cowbell 1	Cowbell 1	DIGI Bell 1
57	Crash 1	Crash 1	Crash 1	Crash 1	Crash 1	Rattles
58	Vibraslap	Vibraslap	Cowbell 1	Cowbell 1	Vibraslap	Ride Bell 1
59	Ride 2	Ride 2	Ride Bell 1	Ride Bell 1	Ride 1	REV Tamb
C4 60	Bongo Hi	Bongo Hi	Cga Mute Hi	Cga Mute Hi	Bongo Hi	2.2 Vibwave
61	Bongo Lo	Bongo Lo	Cga Mute Lo	Cga Mute Lo	Bongo Lo	Low Pink NZ
62	Cga Mute Hi	Cga Mute Hi	Cga Slap	Cga Slap	Cga Mute Hi	Kalimba
63	Cga Open Hi	Cga Open Hi	Cga Open Hi	Cga Open Hi	Cga Open Hi	Metal Wind
64	Cga Open Lo	Cga Open Lo	Cga Open Lo	Cga Open Lo	Cga Open Lo	Lead Wave
65	Timbale	Timbale	Timbale	Timbale	Timbale	Tin Wave
66	Timbale	Timbale	Timbale	Timbale	Timbale	Agogo
67	Agogo	Agogo	Agogo	Agogo	Agogo	Lite Kick
68	Agogo	Agogo	Agogo	Agogo	Agogo	Agogo
69	Cabasa Cut	Cabasa Up	Cabasa Up	Cabasa Up	Cabasa Up	Lite Kick
70	Maracas	Maracas	Maracas	Maracas	Maracas	Agogo
71	Soft Pad B	Soft Pad B	Soft Pad A	Cabasa Down	Soft Pad A	Gtr Harm A
C5 72	Soft Pad A	Soft Pad A	Soft Pad B	Cabasa Cut	Soft Pad B	Gtr Harm A
73	Long Guiro	Long Guiro	Long Guiro	808 Kick	Long Guiro	Piano Thump
74	Long Guiro	Long Guiro	Long Guiro	808 SN	Long Guiro	Natural SN1
75	Claves	Claves	Claves	DIGI Bell 1	Claves	Hand Claps
76	Wood Block	Wood Block	Wood Block	808 SN	Wood Block	Natural SN1
77	Wood Block	Wood Block	Wood Block	808 Kick	Wood Block	808 SN
78	Cuica	Cuica	Cuica	Spectrum	Cuica	PowerChord B
79	Cuica	Cuica	Cuica	808 Kick	Cuica	Hybrid Kick2
80	Open Triangl	Open Triangl	Open Triangl	Spectrum	Open Triangl	PowerChord B
81	Open Triangl	Open Triangl	Open Triangl	808 Kick	Open Triangl	Gt.FretNoise
82	Cabasa Cut	Cabasa Cut	Cabasa Cut	Spectrum	Maracas	Banjo B
83	Tambourine	Spectrum	Spectrum	808 Kick	Ice Rain	Slap Bass 1
C6 84	Old Kick	Wind Chimes	Wind Chimes	808 Kick	Wind Chimes	Oboe mf A
85	Scratch 1	Wood Block	Wood Block	Feedbackwave	Claves	Shakuhachi
86	Piccolo SN	Cga Slap	Cga Slap	808 Kick	808 SN	Pizz
87	Scratch 3	Dry Tom Lo	Dry Tom Lo	Feedbackwave	Verb Tom Hi	Syn Vox 1
88	White Noise	Lite Kick	Lite Kick	Pop Voice	Piccolo SN	Voice Aahs A
89	Synth Saw 1	Hybrid Kick2	Hybrid Kick2	Pop Voice	Scratch 3	Voice Oohs2A
90	Synth Pulse1	Old Kick	Old Kick	Wind Agogo	Tin Wave	Pop Voice
91	Back Hit	808 Kick	Pop Voice	Pop Voice	Spectrum	Male Ooh A
92	Tekno Hit	Natural SN1	Wind Agogo	Wind Agogo	REV Steel DR	Voice Breath
93	Orch. Hit	Natural SN2	Op HiHat	Op HiHat	REV Tin Wave	Org Vox C
94	Philly Hit	SN Roll	Anklungs	Anklungs	REV PiccloSN	Vox Noise
95	REV Back Hit	Natural SN2	Op HiHat	Op HiHat	REV Crash 1	Vox Noise
C7 96	MC500 Beep 1	Metronome 2	Metronome 2	Metronome 2	Metronome 2	Applause
97	R8 Click	R8 Click	R8 Click	R8 Click	R8 Click	R8 Click
98	MC500 Beep 2	Metronome 1	Metronome 1	Metronome 1	Metronome 1	Metronome 2

Rhythm Set List

	PR-C (Preset C Group)		PR-D (GM Group)		PR-E (Preset E Group)	
Note No.	001 JazzDrumSet2	002 OrchDrumSet	001 GM Drum Set	002 BrushDrumSet	001 PowerDrmSet2	002 PowerRaveSet
C2 35	Round Kick	Old Kick	Verb Kick	Hybrid Kick2	Verb Kick	Verb Kick
36	Old Kick	Round Kick	Hybrid Kick1	Hybrid Kick1	Round Kick	Round Kick
37	Side Stick	Side Stick	Side Stick	Side Stick	Dry Stick	Dry Stick
38	Ballad SN	Ballad SN	Ballad SN	Brush Swish	Piccolo SN	Piccolo SN
39	Hand Claps	808 Claps	808 Claps	Brush Slap	808 Claps	808 Claps
40	SN Roll	SN Roll	Piccolo SN	Brush Roll	SN Roll	Natural SN2
41	Verb Tom Lo	Timpani	Verb Tom Lo	Dry Tom Lo	Verb Tom Lo	Verb Tom Lo
42	Cl HiHat 2	Timpani	Cl HiHat 1	Cl HiHat 1	Cl HiHat 1	Cl HiHat 1
43	Dry Tom Lo	Timpani	Verb Tom Lo	Dry Tom Lo	Verb Tom Lo	Verb Tom Lo
44	Pedal HiHat	Timpani	Pedal HiHat	Pedal HiHat	Pedal HiHat	Pedal HiHat
45	Verb Tom Lo	Timpani	Verb Tom Hi	Dry Tom Hi	Verb Tom Lo	Verb Tom Lo
46	Op HiHat	Timpani	Op HiHat	Op HiHat	Op HiHat	Op HiHat
47	Dry Tom Lo	Timpani	Verb Tom Hi	Dry Tom Hi	Verb Tom Lo	Verb Tom Lo
C3 48	Verb Tom Hi	Timpani	Verb Tom Hi	Dry Tom Hi	Verb Tom Hi	Verb Tom Hi
49	Crash 1	Timpani	Crash 1	Crash 1	Crash 1	Crash 1
50	Dry Tom Hi	Timpani	Verb Tom Hi	Dry Tom Hi	Verb Tom Hi	Verb Tom Hi
51	Ride 2	Timpani	Ride 2	Ride 2	Ride 1	Ride 1
52	China Cym	Timpani	China Cym	China Cym	China Cym	China Cym
53	Ride Bell 1	Timpani	Ride Bell 1	Ride Bell 1	Ride Bell 1	Ride Bell 1
54	Tambourine	Tambourine	Tambourine	Tambourine	Tambourine	Tambourine
55	Crash 1	Crash 1	Crash 1	Crash 1	Crash 1	Crash 1
56	Cowbell 1	Cowbell 1	Cowbell 1	Cowbell 1	Cowbell 1	Cowbell 1
57	Crash 1	Crash 1	Crash 1	Crash 1	Crash 1	Crash 1
58	Vibraslap	Ride 1	Vibraslap	Vibraslap	Vibraslap	Vibraslap
59	Ride 2	Ride 2	Ride 2	Ride 2	Ride 1	Ride 1
C4 60	Bongo Hi	Bongo Hi	Bongo Hi	Cga Mute Hi	Bongo Hi	Bongo Hi
61	Bongo Lo	Bongo Lo	Bongo Lo	Cga Mute Lo	Bongo Lo	Bongo Lo
62	Cga Mute Hi	Cga Mute Hi	Cga Mute Hi	Cga Slap	Cga Mute Hi	Cga Mute Hi
63	Cga Open Hi	Cga Open Hi	Cga Open Hi	Cga Open Hi	Cga Open Hi	Cga Open Hi
64	Cga Open Lo	Cga Open Lo	Cga Open Lo	Cga Open Lo	Cga Open Lo	Cga Open Lo
65	Timbale	Timbale	Timbale	Timbale	Timbale	Timbale
66	Timbale	Timbale	Timbale	Timbale	Timbale	Timbale
67	Agogo	Agogo	Agogo	Agogo	Agogo	Agogo
68	Agogo	Agogo	Agogo	Agogo	Agogo	Agogo
69	Cabasa Up	Cabasa Up	Cabasa Up	Cabasa Up	Cabasa Up	Agogo
70	Maracas	Maracas	Maracas	Maracas	Maracas	Maracas
71	Soft Pad A	Soft Pad A	Soft Pad A	Soft Pad A	Soft Pad A	606 HiHat Cl
C5 72	Brush Swish	Soft Pad B	Soft Pad B	Soft Pad B	Soft Pad B	606 HiHat Op
73	Long Guiro	Long Guiro	Long Guiro	Long Guiro	Long Guiro	Long Guiro
74	Long Guiro	Long Guiro	Long Guiro	Long Guiro	Long Guiro	Long Guiro
75	Claves	Claves	Claves	Claves	Claves	Claves
76	Wood Block	Wood Block	Wood Block	Wood Block	Wood Block	Wood Block
77	Metronome 2	Wood Block	Wood Block	Wood Block	Wood Block	Wood Block
78	Cuica	Cuica	Cuica	Cuica	Cuica	Pizz
79	Cuica	Cuica	Cuica	Cuica	Cuica	Syn Vox 1
80	Open Triangl	Open Triangl	Open Triangl	Open Triangl	Open Triangl	Voice Aahs A
81	Open Triangl	Open Triangl	Open Triangl	Open Triangl	Open Triangl	Voice Oohs2A
82	Cabasa Cut	Cabasa Cut	Cabasa Cut	Cabasa Cut	Maracas	Male Ooh A
83	Spectrum	Spectrum	Spectrum	Spectrum	Ice Rain	Ice Rain
C6 84	Wind Chimes	Wind Chimes	Wind Chimes	Wind Chimes	Wind Chimes	808 SN
85	Wood Block	Wood Block	Wood Block	Wood Block	Claves	808 SN
86	Cga Slap	Cga Slap	Cga Slap	Cga Slap	808 SN	808 SN
87	Dry Tom Lo	Dry Tom Lo	Dry Tom Lo	Dry Tom Lo	Verb Tom Hi	Hand Claps
88	Lite Kick	Applause	Lite Kick	Lite Kick	Piccolo SN	Voice Breath
89	Hybrid Kick2	Hybrid Kick2	Hybrid Kick2	Hybrid Kick2	Scratch 3	Scratch 3
90	Old Kick	Cl HiHat 1	Old Kick	Old Kick	Tin Wave	Tin Wave
91	Natural SN2	Round Kick	808 Kick	808 Kick	Spectrum	Crash 1
92	Natural SN1	Pedal HiHat	Natural SN1	Natural SN1	REV Steel DR	Ride Bell 1
93	Brush Swish	Natural SN2	Natural SN2	Natural SN2	REV Tin Wave	REV Tin Wave
94	Brush Roll	Op HiHat	808 SN	SN Roll	REV PiccloSN	DIGI Bell 1
95	Brush Slap	Brush Slap	Brush Slap	Brush Slap	REV Crash 1	Metal Wind
C7 96	Metronome 2	Brush Swish	Brush Swish	Metronome 2	Metronome 2	Applause
97	R8 Click	Brush Roll	Brush Roll	R8 Click	R8 Click	R8 Click
98	Metronome 1	SN Roll	SN Roll	Metronome 1	Metronome 1	Metronome 1

XP-A (WAVE EXPANSION A: Session)

Note No.	001 SessionSet 1	002 SessionSet 2	003 SessionSet 3	004 SessionSet 4	005 SessionSet 5	006 SessionSet 6	007 SessionSet 7	008 Demo Drum
C2 35	Deep Kick 3	Mix Kick	Deep Kick 3	Dance Kick 2	Kick Ghost	Dance Kick 3	Deep Kick 3	Old Kick
36	Mix Kick	Deep Kick 3	TD7 Kick	Dance Kick 3	Dance Kick 3	Dance Kick 2	Mix Kick	Hybrid Kick1
37	Side Stick	Side Stick	Side Stick	909 Rim 2	909 Rim 2	Mute Snr	Side Stick	Side Stick
38	Solo Snr	Loose Snr	Rap Snr	909 Snr 2	909 Snr 3	Jingle Snr	Solo Snr	Loose Snr
39	HC2 Claps 1	HC2 Claps 1	707 Claps	909 Claps 2	HC2 Claps 2	HC2 Claps 2	707 Claps	Tambrin MENU
40	90's Snare	Ring Snr	House Snr	808 Snr 2	Talk Snr	Tiny Snr 2	Ring Snr	Natural SN2
41	Verb Tom Lo	Verb Tom Lo	Verb Tom Lo	909 Tom 2	909 Tom 2	909 Tom 2	909 Tom 2	Verb Tom Lo
42	CI HiHat 1	CI HiHat 1	CI HiHat 1	606 HiHat Cl	606 HiHat Cl	606 HiHat Cl	606 HiHat Cl	CI HiHat 1
43	Verb Tom Lo	Verb Tom Lo	Verb Tom Lo	Verb Tom Lo	Verb Tom Lo	Verb Tom Lo	Verb Tom Lo	Verb Tom Lo
44	CI HiHat 2	CI HiHat 2	CI HiHat 2	606 HiHat Op	606 HiHat Op	606 HiHat Op	606 HiHat Cl	Pedal HiHat
45	Verb Tom Hi	Verb Tom Hi	Verb Tom Hi	909 Tom 2	909 Tom 2	909 Tom 2	909 Tom 2	Verb Tom Hi
46	Op HiHat	Op HiHat	Op HiHat	606 HiHat Op	606 HiHat Op	606 HiHat Op	606 HiHat Op	Op HiHat
47	Verb Tom Hi	Verb Tom Hi	Verb Tom Hi	Verb Tom Hi	Verb Tom Hi	Verb Tom Hi	Verb Tom Hi	Verb Tom Hi
C3 48	Verb Tom Hi	Verb Tom Hi	Verb Tom Hi	909 Tom 2	909 Tom 2	909 Tom 2	909 Tom 2	Verb Tom Hi
49	Crash 1	Crash 1	Crash 1	Crash 1	Crash 1	Crash 1	Crash 1	Crash 1
50	Verb Tom Hi	Verb Tom Hi	Verb Tom Hi	Verb Tom Hi	Verb Tom Hi	Verb Tom Hi	Verb Tom Hi	Verb Tom Hi
51	Ride 2	Ride 2	Ride 2	Ride 2	Ride 2	Ride 2	Ride 2	Ride 1
52	China Cym	China Cym	China Cym	China Cym	China Cym	China Cym	China Cym	China Cym
53	Ride Bell 1	Ride Bell 1	Ride Bell 1	Ride Bell 1	Ride Bell 1	Ride Bell 1	Ride Bell 1	Ride Bell 1
54	Tamb.Long	Tamb.Long	Tamb.Long	CR78 Tamb.	CR78 Tamb.	CR78 Tamb.	CR78 Tamb.	Tamb.Long
55	Crash 1	Crash 1	Crash 1	Crash 1	Crash 1	Crash 1	Crash 1	Crash 1
56	Cowbell 1	Cowbell 1	Cowbell 1	Cowbell 1	Cowbell 1	Cowbell 1	Cowbell 1	Cowbell 1
57	Crash 1	Crash 1	Crash 1	Crash 1	Crash 1	Crash 1	Crash 1	Crash 1
58	Cowbell 1	Cowbell 1	Cowbell 1	Cowbell 1	Cowbell 1	Cowbell 1	Cowbell 1	Vibraslap
59	Ride Bell 1	Ride Bell 1	Ride Bell 1	Ride Bell 1	Ride Bell 1	Ride Bell 1	Ride Bell 1	Ride 2
C4 60	Bongo3 High	Bongo3 High	Bongo3 High	Bongo3 High	Bongo3 High	Bongo3 High	Bongo3 High	Bongo Hi
61	Bongo3 Low	Bongo3 Low	Bongo3 Low	Bongo3 Low	Bongo3 Low	Bongo3 Low	Bongo3 Low	Bongo Lo
62	Cga Slap	Cga Slap	Cga Slap	Cga Slap	Cga Slap	Cga Slap	Cga Slap	Cga Mute Hi
63	Cga Open Hi	Cga Open Hi	Cga Open Hi	Cga Open Hi	Cga Open Hi	Cga Open Hi	Cga Open Hi	Cga Open Hi
64	Cga Open Lo	Cga Open Lo	Cga Open Lo	Cga Open Lo	Cga Open Lo	Cga Open Lo	Cga Open Lo	Cga Open Lo
65	Timbale	Timbale	Timbale	Timbale	Timbale	Timbale	Timbale	Timbale
66	Timbale	Timbale	Timbale	Timbale	Timbale	Timbale	Timbale	Timbale
67	Agogo	Agogo	Agogo	Agogo	Agogo	Agogo	Agogo	Agogo
68	Agogo	Agogo	Agogo	Agogo	Agogo	Agogo	Agogo	Agogo
69	Shaker 4	Shaker 4	Shaker 4	Shaker 4	626 Shaker	626 Shaker	626 Shaker	Cabasa Up
70	Shaker 5	Shaker 5	Shaker 5	Shaker 5	Shaker 4	Shaker 4	Shaker 4	Maracas
71	Soft Pad A	Soft Pad A	Soft Pad A	Soft Pad A	Soft Pad A	Soft Pad A	Soft Pad A	Soft Pad A
C5 72	Soft Pad B	Soft Pad B	Soft Pad B	Soft Pad B	Soft Pad B	Soft Pad B	Soft Pad B	Soft Pad B
73	Long Guiro	Long Guiro	Long Guiro	Long Guiro	Long Guiro	Long Guiro	Long Guiro	Long Guiro
74	Long Guiro	Long Guiro	Long Guiro	Long Guiro	Long Guiro	Long Guiro	Long Guiro	Long Guiro
75	Claves	Claves	Claves	Claves	Claves	Claves	Claves	Claves
76	Wood Block	Wood Block	Wood Block	Wood Block	Wood Block	Wood Block	Wood Block	Wood Block
77	Wood Block	Wood Block	Wood Block	Wood Block	Wood Block	Wood Block	Wood Block	Wood Block
78	Cuica	Cuica	Cuica	Cuica	Cuica	Cuica	Cuica	Shaker 3
79	Cuica	Cuica	Cuica	Cuica	Cuica	Cuica	Cuica	Cuica
80	Open Triangl	Open Triangl	Open Triangl	Open Triangl	Open Triangl	Open Triangl	Open Triangl	606 HiHat Cl
81	Open Triangl	Open Triangl	Open Triangl	Open Triangl	Open Triangl	Open Triangl	Open Triangl	Open Triangl
82	Cabasa Cut	Cabasa Cut	Cabasa Cut	Cabasa Cut	Cabasa Cut	Cabasa Cut	Cabasa Cut	606 HiHat Op
83	Auhvox	Auhvox	REV Gt Scrap	Auhvox	Auhvox	Auhvox	REV Shaker 5	Ride 2
C6 84	Tekno Hit 3	Gtr Feedback	REV Gt SlidNz	Tekno Hit 3	Tekno Hit 3	Tekno Hit 3	REV Shaker 4	Dance Kick 2
85	Tekno Hit 3	Gtr Scrap	REV Gt CutNz	Tekno Hit 3	Tekno Hit 3	Tekno Hit 3	REV Shaker 3	Dance Kick 2
86	Tekno Hit 2	Gtr Slid Nz	REV Gt Slap	Tekno Hit 2	Tekno Hit 2	Tekno Hit 2	REV 626Shakr	House Snr
87	Tekno Hit 2	Gtr Cut Nz	REV TeknHit2	Tekno Hit 2	Tekno Hit 2	Tekno Hit 2	REV CR78Tamb	Tiny Snr 2
88	FX Bell 2fw	Gtr Slap	REV TeknHit3	FX Bell 2fw	REV Dance K3	Tekno Loop	REV Tamb.Lng	Tiny Snr 2
89	FX Bell 1fw	Wah Down 1	REV Dance K3	FX Bell 1fw	REV TeknHit3	REV TeknHit3	REV Tamb.Sht	Hybrid Kick2
90	FX Bomb	Wah Up 1	REV 909 Snr2	FX Bomb	REV TeknHit3	REV TeknHit3	REV Bongo3 H	Old Kick
91	Sm.Club fw	Wah Down 2	REV 909 Snr3	Sm.Club fw	REV TeknHit2	REV TeknHit2	REV Bongo3 L	Dance Kick 2
92	HC2 Claps 2	Wah Up 2	REV Rap Snr	HC2 Claps 2	REV TeknHit2	REV TeknHit2	REV F.Snap 3	Loose Snr
93	Gtr Scrap	Sm.Club	REV Talk Snr	FingerSnaps2	REV 808 Snr2	Blaster A	REV F.Snaps2	Natural SN2
94	707 Claps	Sm.Club fw	REV JnglSnr	707 Claps	REV 909 Snr2	Juno Rave A	REV HC2 Clp2	Tiny Snr 2
95	Gtr Slid Nz	FX Bell 1fw	REV HouseSnr	626 Shaker	REV 909 Snr3	Hard 5ths A	REV 707 Clps	Wind Chimes
C7 96	Gtr Cut Nz	FX Bell 2fw	REV Mute Snr	Tamb.Short	REV HC2 Clp1	CR78 Tamb.	REV HC2 Clp1	Dry Tom Lo
97	R8 Click	R8 Click	R8 Click	R8 Click	R8 Click	R8 Click	R8 Click	Piccolo SN
98	Gtr Slap	REV Snr Buzz	REV 909 Rim2	Tamb.Long	REV 707 Clps	FingerSnap 3	REV 909 Clp2	Dry Tom Lo

Rhythm Set List

XP-C (WAVE EXPANSION C: Techno Collection)

Note No.	001 TR-909 SET	002 TR-808 SET	003 TR-606 SET	004 Techno SET	005 House SET	006 Jungle SET	007 Gabba SET	008 Indust. SET
C2 35	Plastic BD 1	TR808 Kick 1	KICK MENU 1	Plastic BD 1	TR909 Kick 1	Tekno Kick	Amsterdam BD	INDUST. MENU
36	TR909 Kick 1	TR808 Kick 1	TR606 Kick 1	TR909 Kick 1	Tekno Kick	JungleKick 2	TR909 Dst BD	INDUST. MENU
37	TR909 Rim	TR808 Rim	TR808 Rim	TR909 Rim	TR909 Rim	Lo-Fi Snare	TR808 RimLng	Thrill
38	TR909 Snr 5	TR808 Snr 1	TR606 Snr 2	TR909 Snr 5	DJ Snare	Urban Snare	SNR MENU 1	PCM Press
39	TR909 Clap	Clap Stop	HC2 Dry Clap	CLAP MENU	TR909 Clap	SNR MENU 5	Comp Clap	Air Gun
40	TR909 Snr 1	TR808 Snr 3	TR606 Snr 1	TR909 Snr 6	TR909 Snr 5	Jungle Snr 4	SNR MENU 1	PCM Press
41	TR909 DstTom	TR808 Tom	TR606 Tom	TR909 Tom	TR707 Tom	TR606 CmpTom	TR909 DstTom	TekRok Snare
42	TR909 CHH 3	TR808 CHH 1	TR606 CHH	TR909 CHH 1	TR909 CHH 1	CHH MENU 2	TR909 PHH 1	TR909 CHH 3
43	TR909 Tom	TR808 Tom	TR606 Tom	TR909 Tom	TR707 Tom	TR606 CmpTom	TR909 DstTom	TekRok Snare
44	TR909 OHH 3	TR808 CHH 2	PHH MENU	TR909 PHH 2	TR909 PHH 1	Rattle Tamb	TR909 PHH 2	TR909 PHH 1
45	TR909 DstTom	TR808 Tom	TR606 Tom	TR909 Tom	TR707 Tom	TR606 CmpTom	TR909 DstTom	TekRok Snare
46	TR909 OHH 3	OHH MENU	TR606 DstOHH	OHH MENU	OHH MENU	TR909 DstOHH	TR909 DstOHH	TR909 DstOHH
47	TR909 Tom	TR808 Tom	TR606 Tom	TR909 Tom	TR707 Tom	TR606 CmpTom	TR909 DstTom	TekRok Snare
C3 48	TR909 DstTom	TR808 Tom	TR606 Tom	TR909 Tom	TR707 Tom	TR606 CmpTom	TR909 DstTom	TekRok Snare
49	TR909 Crash	TR606 Cym 1	TR606 Cym 2	TR909 Crash	TR909 Crash	R8 OHH	TR909 Crash	Indus Snare
50	TR909 Tom	TR808 Tom	TR606 Tom	TR909 Tom	TR707 Tom	TR606 CmpTom	TR909 DstTom	TekRok Snare
51	TR909 Ride	TR606 Cym 1	TR909 Ride	TR707 Ride	TR909 Ride	TR707 Ride	TR707 Ride	TR909 Ride
52	TR909 Crash	TR909 Crash	TR606 Cym 1	TR909 Crash	TR909 Crash	TR909 Crash	TR909DsCrash	Drill Hit
53	TR909 Ride	TR909 Ride	TR707 Ride	China Cym	Rattle Tamb	China Cym	China Cym	ElectricDunk
54	Tambourine 2	Tambourine 2	Tambourine	Tambourine 2	Tambourine 2	Tambourine 2	CR78 CHH	PCM Press
55	TR909DsCrash	TR909 Crash	TR909 Crash	TR909 Crash	TR909 Crash	TR606 Cym 1	Crash 1	TR606 Cym 1
56	TR808Cowbell	TR808Cowbell	TR808Cowbell	TR707Cowbell	TR707Cowbell	Cowbell 1	TR808Cowbell	PC-2 Machine
57	TR606 Cym 1	TR606 Cym 1	TR909 Crash	TR606 Cym 1	Crash 1	TR909 Crash	TR909DsCrash	TR909 Crash
58	PC-2 Machine	TMB&SKR MENU	TMB&SKR MENU	TR808Cowbell	TR808Cowbell	MachineShout	MachineShout	Crash 1
59	TR707 Ride	TR707 Ride	TR707 Ride	TR606 Cym 1	TR606 Cym 1	TR606 DstOHH	TR606 Cym 2	TR606 DstCym
C4 60	Mental Perc	Mental Perc	Mental Perc	PERCUSS MENU	PERCUSS MENU	PERCUSS MENU	PERCUSS MENU	PERCUSS MENU
61	Dr.Beat	Dr.Beat	Dr.Beat	PERCUSS MENU	PERCUSS MENU	PERCUSS MENU	PERCUSS MENU	PERCUSS MENU
62	Cga Open Hi	Cga Open Hi	Cga Open Hi	PERCUSS MENU	PERCUSS MENU	PERCUSS MENU	PERCUSS MENU	PERCUSS MENU
63	Cga Mute Hi	Cga Mute Hi	Cga Mute Hi	PERCUSS MENU	PERCUSS MENU	PERCUSS MENU	PERCUSS MENU	PERCUSS MENU
64	Cga Open Lo	Cga Open Lo	Cga Open Lo	PERCUSS MENU	PERCUSS MENU	PERCUSS MENU	PERCUSS MENU	PERCUSS MENU
65	Timbale	Timbale	Timbale	PERCUSS MENU	PERCUSS MENU	PERCUSS MENU	PERCUSS MENU	PERCUSS MENU
66	PC-2 Spacers	PC-2 Spacers	PC-2 Spacers	PERCUSS MENU	PERCUSS MENU	PERCUSS MENU	PERCUSS MENU	PERCUSS MENU
67	TR727 Agogo	TR727 Agogo	TR727 Agogo	HIT MENU 1	HIT MENU 1	Surdo open	TR727 Agogo	Analog Bird
68	TR727 Agogo	TR727 Agogo	TR727 Agogo	HIT MENU 1	HIT MENU 1	Surdo mute	TR727 Agogo	Analog Bird
69	TMB&SKR MENU	Cabasa Up	Cabasa Up	TechnoShaker	Cabasa Up	TechnoShaker	TechnoShaker	TechnoShaker
70	TMB&SKR MENU	TMB&SKR MENU	TMB&SKR MENU	Dance Shaker	TechnoShaker	Dance Shaker	Dance Shaker	Dance Shaker
71	Plastic BD 2	TR808 Kick 3	Plastic BD 1	TR909 Kick 2	Wet Kick	KICK MENU 1	TR909 Dst BD	TR909 Dst BD
C5 72	TR909 Kick 2	TR808 Kick 2	Culture Kick	Plastic BD 2	Plastic BD 2	JungleKick 1	KICK MENU 2	Turbo Kick
73	TR808 Rim	TR808 RimLng	TR808 Rim	COW&RIM MENU	TR808 Rim	SideStiker	SideStiker	Drill Hit
74	TR909 Snr 1	TR808 Snr 2	CR78 Snare	TR909 Snr 3	SNR MENU 2	MC Snare	Jungle Snr 4	SNR MENU 3
75	CLAP MENU	Clap Stop	TS Clap	TR909 Clap	CLAP MENU	Comp Clap	CLAP MENU	INDUST. MENU
76	TR909 Snr 6	TR808 Snr 4	TR606 Snr 3	TR909 Snr 4	SNR MENU 1	Ragga Snr 2	TR909 Snr 5	Rage Snare
77	TR707 Tom	TR606 Tom	TR606 CmpTom	TR909 DstTom	TR808 Tom	Jungle Snr 5	TR606 CmpTom	Can Tom
78	TR909 CHH 3	TR808 CHH 2	CR78 CHH	TR909 CHH 3	TR707 CHH	TR909 CHH 3	TR909 CHH 3	HIT MENU 1
79	TR707 Tom	TR606 Tom	TR606 CmpTom	TR909 DstTom	TR808 Tom	Jungle Snr 5	TR606 CmpTom	Can Tom
80	TR909 PHH 2	PHH MENU	TR606 PHH	TR909 PHH 1	TR707 PHH	Tambourine 2	TR909 PHH 1	Beam HiQ
81	TR707 Tom	TR606 Tom	TR606 CmpTom	TR909 DstTom	TR808 Tom	Jungle Snr 5	TR606 CmpTom	Can Tom
82	TR909 OHH 1	OHH MENU	CR78 OHH	TR909 OHH 3	OHH MENU	Cym OHH	TR909 OHH 1	TR909 DstOHH
83	Beam HiQ	Beam HiQ	Beam HiQ	Air Gun	Beam HiQ	Beam HiQ	Beam HiQ	Beam HiQ
C6 84	HIT MENU 1	HIT MENU 1	HIT MENU 1	VOCODER MENU	GTR FX MENU	HIT MENU 1	Air Gun	VOCODER MENU
85	May Day Perc	May Day Perc	May Day Perc	Beam HiQ	Org Chord	Thin Beef	ElectricDunk	TR606 Cym 1
86	Techno Scene	Techno Scene	Techno Scene	VOCODER MENU	GTR FX MENU	Analog Bird	Thin Beef	VOCODER MENU
87	Air Gun	Air Gun	Air Gun	May Day Perc	Noisy 101	HIT MENU 2	Drill Hit	CLAP MENU
88	Tekno Hit	Tekno Hit	Tekno Hit	VOCODER MENU	Claptail	Scratch Clap	TAO Hit	VOCODER MENU
89	Organ Hit 2	White Noise	Organ Hit 2	VOCODER MENU	VOCODER MENU	Emergency	Daft Wave	VOCODER MENU
90	Analog Bird	ElectricDunk	Analog Bird	Techno Scene	VOCODER MENU	TR808Cowbell	Thrill	Roll Kick
91	Retro UFO	TR808 PHH	Retro UFO	VOCODER MENU	VOCODER MENU	Talkbox	Emergency	Organ Hit 2
92	ElectronFall	SNR MENU 2	ElectronFall	Analog Bird	VOCODER MENU	Jungle Beep	Dist TekGtr1	Roll Snare
93	JP8000 FBK	JP8000 FBK	JP8000 FBK	VOCODER MENU	120:House 1	TR808 Kick 1	Dist Synth	TR909 DstOHH
94	SNR MENU 2	VOCODER MENU	SNR MENU 2	144:TeknoHAT	120:House 2	Roll Snare	120:House 1	Roll Kick
95	TR808 Kick 1	TR808 Kick 1	TR808 Kick 1	144:Tekno BD	120:House 3	Roll Kick	120:House 3	TR909DsCrash
C7 96	KICK MENU 2	KICK MENU 2	KICK MENU 2	120:TeknoBNG	120:TeknoBNG	160:Drum'nBs	184:Gabba	CLAP MENU
97	MC500 Beep 1	MC500 Beep 1	MC500 Beep 1	MC500 Beep 1	MC500 Beep 1	MC500 Beep 1	MC500 Beep 1	MC500 Beep 1
98	MC500 Beep 2	MC500 Beep 2	MC500 Beep 2	MC500 Beep 2	MC500 Beep 2	MC500 Beep 2	MC500 Beep 2	MC500 Beep 2

Performance List

USER (User Group)

No.	Name	Key Mode
01	EasternSplit	LAYER
02	Opening Orch	LAYER
03	Feedback EP	LAYER
04	Humming Vox	LAYER
05	Tekno Loop 1	LAYER
06	Fr.Horn Sect	LAYER
07	SpaceCarrier	LAYER
08	Orchestral	LAYER
09	Nebular Vox	LAYER
10	Terminator	LAYER
11	Flying Jazz	LAYER
12	Sweeper	LAYER
13	Rave Split	LAYER
14	Multi Sax	LAYER
15	Cosmic Dawn	LAYER
16	Bass / Lead	LAYER
17	S&H / Pad	LAYER
18	AcPiano+Pad	LAYER
19	Kicks Attack	LAYER
20	Step Brass	LAYER
21	Drone / Pipe	LAYER
22	Chime Dreams	LAYER
23	Tekno Loop 2	LAYER
24	Big Band	LAYER
25	Labyrinth	LAYER
26	White Hole	LAYER
27	Cyber Sweep	LAYER
28	Tekno Asia	LAYER
29	1080 Fantasy	LAYER
30	Pop Ballad	LAYER
31	Rhythmic	LAYER
32	Power JV	LAYER

PR-A (Preset A Group)

No.	Name	Key Mode
01	House Set	SINGLE
02	Analectro	SINGLE
03	Anatronic	SINGLE
04	Tekno Pop 1	SINGLE
05	Tekno Pop 2	SINGLE
06	Hard Core	SINGLE
07	Hi Energy	SINGLE
08	Pop Dance	SINGLE
09	Acid Set	SINGLE
10	Ambient Set	SINGLE
11	Electro Pop	SINGLE
12	Pop Set 1	SINGLE
13	Pop Set 2	SINGLE
14	Pop Set 3	SINGLE
15	Pop Set 4	SINGLE
16	L.A. Ballad	SINGLE
17	Hip Hop Set	SINGLE
18	Funk Rock	SINGLE
19	Funk Fusion	SINGLE
20	Heavy Metal	SINGLE
21	Heavy Kids	LAYER
22	Latin Set	SINGLE
23	BrazilianSet	SINGLE
24	New Age 1	SINGLE
25	New Age 2	SINGLE
26	Orchestra	SINGLE
27	Concerto	SINGLE
28	Film Score 1	SINGLE
29	Film Score 2	SINGLE
30	Symphonic	SINGLE
31	Chamber Set	SINGLE
32	Baroque Set	SINGLE

PR-B (Preset B Group)

No.	Name	Key Mode
01	Africa	SINGLE
02	World Ethnic	SINGLE
03	Asian Ethnic	SINGLE
04	Asian Band	SINGLE
05	60's Set	SINGLE
06	Blues Band	SINGLE
07	Country Band	SINGLE
08	Folk Set	SINGLE
09	Reggae Band	SINGLE
10	FunkWah Band	SINGLE
11	Funkin'Phaze	SINGLE
12	Zydeco Band	SINGLE
13	New Orleans	SINGLE
14	Dixieland	SINGLE
15	Big Band Set	SINGLE
16	Cont.Jazz 1	SINGLE
17	Cont.Jazz 2	SINGLE
18	Ac.Jazz Set	SINGLE
19	Gospel Set	SINGLE
20	All Strings	SINGLE
21	All Brass	SINGLE
22	All Piano 1	SINGLE
23	All Piano 2	SINGLE
24	All Keyboard	SINGLE
25	All Organ	SINGLE
26	All Winds	SINGLE
27	All Bells	LAYER
28	Mlt & Perc	SINGLE
29	All Seq	SINGLE
30	All Bass	SINGLE
31	All Pad	SINGLE
32	All FX	SINGLE

Arpeggio Style List

Style	Motif	Beat Pattern	Accent Rate	Shuffle Rate
1/4	all	1/4	0-100%	50-90%
1/6	all	1/6	0-100%	50-90%
1/8	all	1/8	0-100%	50-90%
1/12	all	1/12	0-100%	50-90%
1/16	all	1/16 1-3	0-100%	50-90%
1/32	SINGLE UP, SINGLE DOWN, SINGLE UP&DOWN, SINGLE RANDOM, DUAL UP, DUAL DOWN, DUAL UP&DOWN, DUAL RANDOM, NOTE ORDER, GLISSANDO, BASS+UP 1-8, BASS+RANDOM 1-3, TOP+UP 1-6	1/32 1-3	0-100%	50-90%
PORTAMENTO A	all	PORTA-A 01-11	0-100%	50-90%
PORTAMENTO B	all	PORTA-B 01-15	0-100%	50-90%
GLISSANDO	GLISSANDO	1/16 1-3, 1/32 1-3	0-100%	50-90%
SEQUENCE A	all	SEQ-A 1-7	0-100%	50-90%
SEQUENCE B	all	SEQ-B 1-5	0-100%	50-90%
SEQUENCE C	SINGLE UP, SINGLE DOWN, SINGLE UP&DOWN, SINGLE RANDOM, DUAL UP, DUAL DOWN, DUAL UP&DOWN, DUAL RANDOM, NOTE ORDER, GLISSANDO, BASS+UP 1-8, BASS+RANDOM 1-3, TOP+UP 1-6	SEQ-C 1-2	0-100%	50-90%
SEQUENCE D	all	SEQ-D 1-8	0-100%	50-90%
ECHO	SINGLE UP, SINGLE DOWN, SINGLE UP&DOWN, SINGLE RANDOM, DUAL UP, DUAL DOWN, DUAL UP&DOWN, DUAL RANDOM, NOTE ORDER	ECHO 1-3	0-100%	50-90%
SYNTH BASS	BASS+UP 2	SEQ-A 1, SEQ-C 1	0-100%	50-90%
SLAP BASS A	BASS+UP 5, TOP+UP 5	MUTE 02, 03	0-100%	50-90%
SLAP BASS B	BASS+UP 5, TOP+UP 5	MUTE 02, 03	0-100%	50-90%
WALK BASS	SINGLE UP, SINGLE DOWN, SINGLE UP&DOWN, SINGLE RANDOM, NOTE ORDER, GLISSANDO	WALKBS, REFRAIN 1	0-100%	50-90%
RHYTHM GTR A	SINGLE UP, SINGLE DOWN, SINGLE UP&DOWN, SINGLE RANDOM, DUAL UP, DUAL DOWN, DUAL UP&DOWN, DUAL RANDOM, NOTE ORDER, BASS+UP 1-8, BASS+RANDOM 1-3, TOP+UP 1-6	MUTE 01,04	0-100%	50-90%
RHYTHM GTR B	CHORD	MUTE 07, 13, 14	0-100%	50-90%
RHYTHM GTR C	CHORD	MUTE 08, 12, 15	0-100%	50-90%
RHYTHM GTR D	CHORD	MUTE 09, 10, 11, 16	0-100%	50-90%
RHYTHM GTR E	SINGLE UP, SINGLE DOWN	STRUM 1-6	0-100%	50-90%
3 FINGER GTR	BASS+UP+TOP	SEQ-A 7	0-100%	50-90%
STRUMMING GTR	SINGLE UP, SINGLE DOWN	STRUM 7, 8	0-100%	50-90%
KBD COMPING A	CHORD	MUTE 12, REFRAIN 2	0-100%	50-90%
KBD COMPING B	BASS+CHORD 4, BASS+CHORD 5	MUTE 05, 06	0-100%	50-90%
KBD COMPING C	BASS+CHORD 2, BASS+UP 2, BASS+RANDOM 2, TOP+UP 2	1/6, 1/12	0-100%	50-90%
KBD COMPING D	BASS+CHORD 2, BASS+UP 2, BASS+RANDOM 2, TOP+UP 2	1/16 1-3	0-100%	50-90%
KBD COMPING E	CHORD, BASS+CHORD 1	REGGAE1-2	0-100%	50-90%
PERCUSSION	SINGLE UP, SINGLE DOWN, SINGLE UP&DOWN, SINGLE RANDOM, DUAL UP, DUAL DOWN, DUAL UP&DOWN, DUAL RANDOM, NOTE ORDER, BASS+UP 1-8, BASS+RANDOM 1-3, TOP+UP 1-6	PERC1-4	0-100%	50-90%
HARP	SINGLE UP, SINGLE DOWN, SINGLE UP&DOWN, GLISSANDO	HARP	0-100%	50-90%
SHAMISEN	TOP+UP 4-6	SEQ-A 2	0-100%	50-90%
BOUND BALL	SINGLE UP, SINGLE DOWN, SINGLE UP&DOWN, SINGLE RANDOM, DUAL UP, DUAL DOWN, DUAL UP&DOWN, DUAL RANDOM, NOTE ORDER, GLISSANDO	BOUND	0-100%	50-90%
RANDOM	SINGLE RANDOM, DUAL RANDOM, BASS+RANDOM 1-3	1/4, 1/6, 1/8, 1/12, 1/16 1-3, 1/32 1-3, RANDOM	0-100%	50-90%
BOSSA NOVA	all	BOSSA NOVA	0-100%	50-90%
SALSA	all	SALSA 1-4	0-100%	50-90%
MAMBO	all	MAMBO 1-2	0-100%	50-90%
LATIN PERCUSSION	SINGLE UP, SINGLE DOWN, SINGLE UP&DOWN, SINGLE RANDOM, DUAL UP, DUAL DOWN, DUAL UP&DOWN, DUAL RANDOM, NOTE ORDER, GLISSANDO	CLAVE, REV CLA, GUIRO, AGOGO	0-100%	50-90%
SAMBA	all	SAMBA	0-100%	50-90%
TANGO	all	TANGO 1-4	0-100%	50-90%
HOUSE	all	HOUSE 1-2	0-100%	50-90%
LIMITLESS	all	all	0-100%	50-90%

all: there is no restriction on the value which can be set

MIDI Implementation

Model: XP-30 (64 Voice Expandable Synthesizer)
Version: 1.00
Date: Jan. 18 1999

1. Data Reception (sound source section)

■ Channel Voice Messages

● Note Off

status	2nd byte	3rd byte
8nH	kkH	vvH
9nH	kkH	00H

n=MIDI channel number: 0H - FH (ch.1 - ch.16)
kk=note number: 00H - 7FH (0 - 127)
vv=Note Off velocity: 00H - 7FH (0 - 127)

- * Not received in Performance mode when the Rx parameter (PERFORM/MIDI/MIDI) is OFF.
- * Not received by the Rhythm Part (Part 10) when the Env Mode parameter (RHYTHM/CONTROL/CONTROL) is NO-SUS.

● Note On

status	2nd byte	3rd byte
9nH	kkH	vvH

n=MIDI channel number: 0H - FH (ch.1 - ch.16)
kk=note number: 00H - 7FH (0 - 127)
vv=Note On velocity: 01H - 7FH (1 - 127)

- * Not received in Performance mode when the Rx parameter (PERFORM/MIDI/MIDI) is OFF.

● Polyphonic Aftertouch

status	2nd byte	3rd byte
AnH	kkH	vvH

n=MIDI channel number: 0H - FH (ch.1 - ch.16)
kk=note number: 00H - 7FH (0 - 127)
vv=Aftertouch: 00H - 7FH (0 - 127)

- * This message is received if the Aftertouch parameter (SYSTEM/CONTROL/CONTROL SOURCE) is POLY or CH&POLY.
- * Not received in Performance mode when the Rx parameter (PERFORM/MIDI/MIDI) is OFF.
- * Not received in GM mode.

● Control Change

- * If the corresponding Controller number is selected for the Control 2 or Control 3 parameter (PATCH/CONTROL/CONTROL SOURCE), the corresponding effect will occur.
- * If a Controller number that corresponds to the Control 1 parameter or Control 2 parameter (SYSTEM/CONTROL/SYS-CTRL ASSIGN) is selected, the specified effect will apply if Control 2 parameter or Control 3 parameter (PATCH/CONTROL/CONTROL SOURCE) is set to SYS-CTRL1 or SYS-CTRL2.
- * Not received in Performance mode when the Rx parameter (PERFORM/MIDI/MIDI) or the Control Change Receive Switch is OFF.

○ Bank Select (Controller number 0,32)

status	2nd byte	3rd byte
BnH	00H	mmH
BnH	20H	llH

n=MIDI channel number: 0H - FH (ch.1 - ch.16)
mm,ll=Bank number: 00 00H - 7F 7FH (bank.1 - bank.16384)

- * Not received when the Program Change parameter or Bank Select parameter (SYSTEM/MIDI/RECEIVE MIDI) is OFF.
- * Not received in GM mode.

* The Patches corresponding to each Bank Select are as follows.

Bank Select	Program No	Group	Patch No.	
MSB LSB				
80	0	0 - 127	User	1 - 128
81	0	0 - 127	PR-A	1 - 128
81	1	0 - 127	PR-B	1 - 128
81	2	0 - 127	PR-C	1 - 128
81	3	0 - 127	GM	1 - 128
81	4	0 - 127	PR-E	1 - 128
84	0	0 - 127	XP-A (Session)	1 - 128
84	1	0 - 126	XP-A	129 - 255
84	2	0 - 127	XP-B (Orchestral)	1 - 128
84	3	0 - 126	XP-B	129 - 255
84	4	0 - 127	XP-C (Techno Collection)	1 - 128
84	5	0 - 127	XP-C	129 - 256
84	6	0 - 127	XP-D	1 - 128
84	7	0 - 127	XP-D	129 - 256
84	8	0 - 127	XP-E	1 - 128
84	9	0 - 127	XP-E	129 - 256

* The Performance corresponding to each Bank Select are as follows.

Bank Select	Program No	Group	Performance No.	
MSB LSB				
80	0	0 - 31	User	1 - 32
81	0	0 - 31	PR-A	1 - 32
81	1	0 - 31	PR-B	1 - 32

* The Rhythm set corresponding to each Bank Select are as follows.

Bank Select	Program No	Group	Rhythm set No.	
MSB LSB				
80	0	0 - 1	User	1 - 2
81	0	0 - 1	PR-A	1 - 2
81	1	0 - 1	PR-B	1 - 2
81	2	0 - 1	PR-C	1 - 2
81	3	0 - 1	GM	1 - 2
81	4	0 - 1	PR-E	1 - 2
84	0	0 - 7	XP-A (Session)	1 - 8
84	4	0 - 7	XP-C (Techno Collection)	1 - 8
84	6	0 - 127	XP-D	1 - 128
84	7	0 - 127	XP-D	129 - 256
84	8	0 - 127	XP-E	1 - 128
84	9	0 - 127	XP-E	129 - 256

○ Modulation (Controller number 1)

status	2nd byte	3rd byte
BnH	01H	vvH

n=MIDI channel number: 0H - FH (ch.1 - ch.16)
vv=Modulation depth: 00H - 7FH (0 - 127)

○ Breath Type (Controller number 2)

status	2nd byte	3rd byte
BnH	02H	vvH

n=MIDI channel number: 0H - FH (ch.1 - ch.16)
vv=control value: 00H - 7FH (0 - 127)

○ Foot Type (Controller number 4)

status	2nd byte	3rd byte
BnH	04H	vvH

n=MIDI channel number: 0H - FH (ch.1 - ch.16)
vv=control value: 00H - 7FH (0 - 127)

○ Portamento Time (Controller number 5)

status	2nd byte	3rd byte
BnH	05H	vvH

n=MIDI channel number: 0H - FH (ch.1 - ch.16)
vv=Portamento Time: 00H - 7FH (0 - 127)

* The Time parameter (PATCH/CONTROL/PORTAMENTO) will change.

○ Data Entry (Controller number 6, 38)

status	2nd byte	3rd byte
BnH	06H	mmH
BnH	26H	llH

n=MIDI channel number: 0H - FH (ch.1 - ch.16)
mm,ll= the value of the parameter specified by RPN/NRPN
mm=MSB, ll=LSB

○ Volume (Controller number 7)

status	2nd byte	3rd byte
BnH	07H	vvH

n=MIDI channel number: 0H - FH (ch.1 - ch.16)
vv=Volume: 00H - 7FH (0 - 127)

MIDI Implementation

○Balance (Controller number 8)

status	2nd byte	3rd byte
BnH	08H	vvH
n=MIDI channel number:	0H - FH (ch.1 - ch.16)	
vv=Balance:	00H - 7FH (0 - 127)	

○Panpot (Controller number 10)

status	2nd byte	3rd byte
BnH	0AH	vvH
n=MIDI channel number:	0H - FH (ch.1 - ch.16)	
vv=Panpot:	00H - 40H - 7FH (left - center - right)	

* Adjust the stereo location over 128 steps, where 0 is far left, 64 is center, and 127 is far right. However this is not received when the Pan parameter (PATCH/CONTROL/RxSWITCH) is OFF.

○Expression (Controller number 11)

status	2nd byte	3rd byte
BnH	0BH	vvH
n=MIDI channel number:	0H - FH (ch.1 - ch.16)	
vv=Expression:	00H - 7FH (0 - 127)	

* If the Volume parameter (SYSTEM/CONTROL/CONTROL SOURCE) is set to VOL&EXP, the volume of the Part corresponding to the MIDI channel of the received message will be adjusted. However this is not received if the Volume parameter (PATCH/CONTROL/RxSWITCH) is OFF.

* In GM mode, the volume can always be controlled.

○Hold 1 (Controller number 64)

status	2nd byte	3rd byte
BnH	40H	vvH
n=MIDI channel number:	0H - FH (ch.1 - ch.16)	
vv=control value:	00H - 7FH (0 - 127) 0-63=OFF, 64-127=ON	

* Not received when the Hold-1 RxSwitch parameter (PATCH/CONTROL/DAMPER) is OFF.

○Portamento (Controller number 65)

status	2nd byte	3rd byte
BnH	41H	vvH
n=MIDI channel number:	0H - FH (ch.1 - ch.16)	
vv=control value:	00H - 7FH (0 - 127) 0-63=OFF, 64-127=ON	

* The Sw parameter (PATCH/CONTROL/PORTAMENTO) will change.

○Sostenuto (Controller number 66)

status	2nd byte	3rd byte
BnH	42H	vvH
n=MIDI channel number:	0H - FH (ch.1 - ch.16)	
vv=control value:	00H - 7FH (0 - 127) 0-63=OFF, 64-127=ON	

○Soft (Controller number 67)

status	2nd byte	3rd byte
BnH	43H	vvH
n=MIDI channel number:	0H - FH (ch.1 - ch.16)	
vv=control value:	00H - 7FH (0 - 127) 0-63=OFF, 64-127=ON	

○Hold 2 (Controller number 69)

status	2nd byte	3rd byte
BnH	45H	vvH
n=MIDI channel number:	0H - FH (ch.1 - ch.16)	
vv=control value:	00H - 7FH (0 - 127)	

* A hold movement isn't done.

○Sound Controller 2 (Controller number 71)

status	2nd byte	3rd byte
BnH	47H	vvH
n=MIDI channel number:	0H - FH (ch.1 - ch.16)	
vv=control value:	00H - 40H - 7FH (-128 - 0 - +126)	

* The Res parameter (PATCH/TVF/FILTER) will change relatively.

○Sound Controller 3 (Controller number 72)

status	2nd byte	3rd byte
BnH	48H	vvH
n=MIDI channel number:	0H - FH (ch.1 - ch.16)	
vv=control value:	00H - 40H - 7FH (-128 - 0 - +126)	

* The T2-4 parameter (PATCH/TVF/TVF ENVELOPE), The T2-4 parameter (PATCH/TVA/TVA ENVELOPE) will change relatively.

○Sound Controller 4 (Controller number 73)

status	2nd byte	3rd byte
BnH	49H	vvH
n=MIDI channel number:	0H - FH (ch.1 - ch.16)	
vv=control value:	00H - 40H - 7FH (-128 - 0 - +126)	

* The T1 parameter (PATCH/TVF/TVF ENVELOPE), The T1 parameter (PATCH/TVA/TVA ENVELOPE) will change relatively.

○Sound Controller 5 (Controller number 74)

status	2nd byte	3rd byte
BnH	4AH	vvH
n=MIDI channel number:	0H - FH (ch.1 - ch.16)	
vv=control value:	00H - 40H - 7FH (-64 - 0 - +63)	

* The Cut parameter (PATCH/TVF/FILTER) will change relatively.

○General Purpose Controller 5 (Controller number 80)

status	2nd byte	3rd byte
BnH	50H	vvH
n=MIDI channel number:	0H - FH (ch.1 - ch.16)	
vv=control value:	00H - 40H - 7FH (-128 - 0 - +126)	

* The L1-3 parameter (PATCH/TVA/TVA ENVELOPE) of Tone 1 will change relatively.

○General Purpose Controller 6 (Controller number 81)

status	2nd byte	3rd byte
BnH	51H	vvH
n=MIDI channel number:	0H - FH (ch.1 - ch.16)	
vv=control value:	00H - 40H - 7FH (-128 - 0 - +126)	

* The L1-3 parameter (PATCH/TVA/TVA ENVELOPE) of Tone 2 will change relatively.

○General Purpose Controller 7 (Controller number 82)

status	2nd byte	3rd byte
BnH	52H	vvH
n=MIDI channel number:	0H - FH (ch.1 - ch.16)	
vv=control value:	00H - 40H - 7FH (-128 - 0 - +126)	

* The L1-3 parameter (PATCH/TVA/TVA ENVELOPE) of Tone 3 will change relatively.

○General Purpose Controller 8 (Controller number 83)

status	2nd byte	3rd byte
BnH	53H	vvH
n=MIDI channel number:	0H - FH (ch.1 - ch.16)	
vv=control value:	00H - 40H - 7FH (-128 - 0 - +126)	

* The L1-3 parameter (PATCH/TVA/TVA ENVELOPE) of Tone 4 will change relatively.

○Portamento Control (Controller number 84)

status	2nd byte	3rd byte
BnH	54H	kkH
n=MIDI channel number:	0H - FH (ch.1 - ch.16)	
kk=source note number:	00H - 7FH (0 - 127)	

* A Note On message received immediately after a Portamento control will be sounded with the pitch changing smoothly from the source note number. If a voice is already sounding at the same note number as the source note number, that voice will change pitch to the pitch of the newly received Note On, and continue sounding (i.e., will be played legato).

* The speed of the pitch change caused by Portamento is determined by the Time parameter (PATCH/CONTROL/PORTAMENTO) value.

○ Effect 1 (Reverb Send Level) (Controller number 91)

status	2nd byte	3rd byte
BnH	5BH	vvH
n=MIDI channel number:	0H - FH (ch.1 - ch.16)	
vv=Reverb Send Level:	00H - 7FH (0 - 127)	

* In Performance mode, the Reverb Send Level parameter of each Part will change.

○ Effect 3 (Chorus Send Level) (Controller number 93)

status	2nd byte	3rd byte
BnH	5DH	vvH
n=MIDI channel number:	0H - FH (ch.1 - ch.16)	
vv=Chorus Send Level:	00H - 7FH (0 - 127)	

* In Performance mode, the Chorus Send Level parameter of each Part will change.

○ RPN MSB/LSB (Controller number 100, 101)

status	2nd byte	3rd byte
BnH	65H	mmH
BnH	64H	llH
n=MIDI channel number:	0H - FH (ch.1 - ch.16)	
mm=MSB of the parameter number specified by RPN		
ll=LSB of the parameter number specified by RPN		

<<< RPN >>>

Control Changes include RPN (Registered Parameter Numbers), which are extended parameters whose function is defined in the MIDI specification. When using RPNs, first the RPN (Controller numbers 100 and 101; they can be sent in any order) is transmitted to specify the parameter you wish to control. Then, Data Entry messages (Controller numbers 6 and 38) are used to set the value of the specified parameter. Once a RPN parameter has been specified, all further Data Entry messages on that channel are considered to apply to that specified parameter. In order to prevent accidents, when the desired setting has been made for the parameter, it is recommended that RPN be set to Null.

This device receives the following RPNs.

RPN	Data entry	Notes
<u>MSB LSB</u> 00H 00H	<u>MSB LSB</u> mmH -	Pitch Bend Sensitivity mm : 00H - 0CH (0 - 12 semitones) ll : ignored (processed as 00H) Up to 1 octave can be specified in semitone steps. *The Bend Range parameter (PATCH/CONTROL/KEY MODE & BENDER) will also be changed. *Not received by the Rhythm Part (Part 10).
00H 01H	mmH llH	Channel Fine Tuning mm, ll : 20 00H - 40 00H - 60 00H (-4096 x 100 / 8192 - 0 - +4096 x 100 / 8192 cent) *In Patch mode, the Master parameter (SYSTEM/TUNE/TUNE) will change. *In Performance mode, the Fine parameter (PERFORM/PART/SETTING) of each Part will change. When received on the Control channel, the Master parameter (SYSTEM/TUNE/TUNE) will change.
00H 02H	mmH -	Channel Coarse Tuning mm : 10H - 40H - 70H (-48 - 0 - +48 semitones) ll : ignored (processed as 00H) *Not received in Patch mode. *In Performance mode, the Coarse parameter (PERFORM/PART/SETTING) of each Part will change.
7FH 7FH	--	RPN null RPN and NRPN will be set as "unspecified." Once this setting has been made, subsequent Data Entry messages will be ignored. (It is not necessary to transmit Data Entry for RPN Null settings. Parameter values that were previously set will not change. mm, ll: ignored

● Program Change

status	2nd byte
CnH	ppH
n=MIDI channel number:	0H - FH (ch.1 - ch.16)
pp=Program number:	00H - 7FH (prog.1 - prog.128)

* Not received when the Program Change parameter (SYSTEM/MIDI/RECEIVE MIDI) is OFF.

* When received on the Control channel, the Performance will change.

* Not received in Performance mode when the Rx parameter (PERFORM/MIDI/MIDI) is OFF.

● Channel Aftertouch

status	2nd byte
DnH	vvH
n=MIDI channel number:	0H - FH (ch.1 - ch.16)
vv=Channel Aftertouch:	00H - 7FH (0 - 127)

* Not received in Performance mode when the Rx parameter (PERFORM/MIDI/MIDI) is OFF.

● Pitch Bend Change

status	2nd byte	3rd byte
EnH	llH	mmH
n=MIDI channel number:	0H - FH (ch.1 - ch.16)	
mm,ll=Pitch Bend value:	00 00H - 40 00H - 7F 7FH (-8192 - 0 - +8191)	

* Not received in Performance mode when the Rx parameter (PERFORM/MIDI/MIDI) is OFF.

■ Channel Mode Messages

● All Sound Off (Controller number 120)

status	2nd byte	3rd byte
BnH	78H	00H
n=MIDI channel:	0H - FH (ch.1 - ch.16)	

* When this message is received, all notes currently sounding on the corresponding channel will be turned off.

* Not received in Performance mode when the Rx parameter (PERFORM/MIDI/MIDI) is OFF.

● Reset All Controllers (Controller number 121)

status	2nd byte	3rd byte
BnH	79H	00H
n=MIDI channel number:	0H - FH (ch.1 - ch.16)	

* Not received in Performance mode when the Rx parameter (PERFORM/MIDI/MIDI) is OFF.

* When this message is received, the following controllers will be set to their reset values.

Controller	Reset value
Pitch Bend Change	[+ -]0 (center)
Polyphonic Key Pressure	0 (off)
Channel Pressure	0 (off)
Modulation	0 (off)
Breath type	0 (minimum)
Expression	127 (maximum) However the controller will be at minimum.
Hold 1	0 (off)
Sostenuto	0 (off)
Soft	0 (off)
Hold 2	0 (off)
RPN	Unset. Previously set data will not change.
NRPN	Unset. Previously set data will not change.
System General purpose controller 10	(minimum)
System General purpose controller 20	(minimum)

MIDI Implementation

● All Note Off (Controller number 123)

status	2nd byte	3rd byte
BnH	7BH	00H

n=MIDI channel number: 0H - FH (ch.1 - ch.16)

- * When All Note Off is received, all currently sounding notes of the corresponding channel will be turned off. However if Hold 1 or Sostenuto are on, the sound will be held until these are turned off.
- * Not received in Performance mode if Rx parameter (PERFORM/MIDI/MIDI) is OFF.

● Omni Off (Controller number 124)

status	2nd byte	3rd byte
BnH	7CH	00H

n=MIDI channel number: 0H - FH (ch.1 - ch.16)

- * The same processing as when All Note Off is received will be done.
- * Not received in Performance mode if Rx parameter (PERFORM/MIDI/MIDI) is OFF.

● Omni On (Controller number 125)

status	2nd byte	3rd byte
BnH	7DH	00H

n=MIDI channel number: 0H - FH (ch.1 - ch.16)

- * The same processing as when All Note Off is received will be done. The instrument will not be set to OMNI ON.
- * Not received in Performance mode if Rx parameter (PERFORM/MIDI/MIDI) is OFF.

● Mono (Controller number 126)

status	2nd byte	3rd byte
BnH	7EH	mmH

n=MIDI channel number: 0H - FH (ch.1 - ch.16)
mm=Mono number: 00H - 10H (0 - 16)

- * The same processing as when All Note Off is received will be done, and the Assign parameter (PATCH/CONTROL/KEY MODE & BENDER) will be set to SOLO.
- * Not received in Performance mode if Rx parameter (PERFORM/MIDI/MIDI) is OFF.

● Poly (Controller number 127)

status	2nd byte	3rd byte
BnH	7FH	00H

n=MIDI channel number: 0H - FH (ch.1 - ch.16)

- * The same processing as when All Note Off is received will be done, and the Assign parameter (PATCH/CONTROL/KEY MODE & BENDER) will be set to POLY.
- * Not received in Performance mode if Rx parameter (PERFORM/MIDI/MIDI) is OFF.

■ System Realtime Messages

● Timing Clock

status
F8H

- * This message will be received if the Clock Source parameter (SYSTEM/SETUP/SYSTEM SETUP) is MIDI (p. 129).

● Active Sensing

status
FEH

- * When an Active Sensing message is received, the unit will begin monitoring the interval at which MIDI messages are received. During monitoring, if more than 420 ms passes without a message being received, the same processing will be done as when All Sound Off, All Note Off, and Reset All Controllers messages are received. Then monitoring will be halted.

■ System Exclusive Messages

status	data byte	status
F0H	iiH, ddH,, eeH	F7H

F0H:	System Exclusive message status
ii = ID number:	This is the ID number (manufacturer ID) that specifies the manufacturer whose exclusive message this is. Roland's manufacturer ID is 41H. ID numbers 7EH and 7FH are defined in an expansion of the MIDI standard as Universal Non-realtime messages (7EH) and Universal Realtime Messages (7FH).
dd, ..., ee = data:	00H - 7FH (0 - 127)
F7H:	EOX (End Of Exclusive)

Of the System Exclusive messages received by this device, the Universal Non-realtime messages and the Universal Realtime messages and the Data Request (RQ1) messages and the Data Set (DT1) messages will be set automatically.

● Universal Non-realtime System Exclusive Messages

○ Identity Request Message

When this message is received, Identity Reply message (p. 189) will be transmitted.

status	data byte	status
F0H	7EH, dev, 06H, 01H	F7H

Byte	Remarks
F0H	Exclusive status
7EH	ID number (Universal Non-realtime message)
dev	device ID (dev: 10H - 1FH)
06H	sub ID#1 (General Information)
01H	sub ID#2 (Identity Request)
F7H	EOX (End Of Exclusive)

- * The "dev" is own device number or 7FH (Broadcast).

○ GM System On

"GM System On" is a command message that resets the internal settings of the instrument to the GM initial state (General MIDI System - Level 1). A GM instrument that receives this message will automatically enter a state in which it can correctly perform a GM score.

status	data byte	status
F0H	7EH, 7FH, 09H, 01H	F7H

Byte	Remarks
F0H	Exclusive status
7EH	ID number (Universal Non-realtime message)
7FH	device ID (Broadcast)
09H	sub ID#1 (General MIDI Message)
01H	sub ID#2 (General MIDI On)
F7H	EOX (End Of Exclusive)

- * Not received when the Rx.GM parameter (SYSTEM/MIDI/SYS-EXC MIDI) is OFF.

○ GM System Off

When this messages is received, this instrument will return to the performance mode.

status	data byte	status
F0H	7EH, 7FH, 09H, 02H	F7H

Byte	Remarks
F0H	Exclusive status
7EH	ID number (Universal Non-realtime message)
7FH	device ID (Broadcast)
09H	sub ID#1 (General MIDI Message)
02H	sub ID#2 (General MIDI Off)
F7H	EOX (End Of Exclusive)

- * Not received when the Rx.GM parameter (SYSTEM/MIDI/SYS-EXC MIDI) is OFF.

● Universal Realtime System Exclusive messages

○ Master Volume

status	data byte	status
F0H	7FH, 7FH, 04H, 01H, 11H, mmH	F7H

Byte	Remarks
F0H	Exclusive status
7FH	ID number (Universal Realtime message)
7FH	device ID (Broadcast)
04H	sub ID#1 (Device Control Message)
01H	sub ID#2 (Master Volume)
11H	LSB of Master Volume
mmH	MSB of Master Volume
F7H	EOX (End Of Exclusive)

- * LSB of Master Volume (11H) is processed as 00H.
- * This message is not received if the Rx.Exc parameter (SYSTEM/MIDI/SYS-EXC MIDI) is OFF.
- * This message is not received in GM mode.

● Data Transmission

This instrument can use exclusive messages to exchange many varieties of internal settings with other devices.

The model ID of the exclusive messages used by this instrument is 6AH.

○ Data Request 1 RQ1

This message requests the other device to transmit data. The address and size indicate the type and amount of data that is requested.

When a Data Request message is received, if the device is in a state in which it is able to transmit data, and if the address and size are appropriate, the requested data is transmitted as a Data Set 1 (DT1) message. If the conditions are not met, nothing is transmitted.

status	data byte	status
F0H	41H, dev, 6AH, 11H, aaH, bbH, ccH, ddH, ssH, ttH, uuH, vvH, sum	F7H

Byte	Remarks
F0H	Exclusive status
41H	ID number (Roland)
dev	device ID (dev: 10H - 1FH)
6AH	model ID (XP-30)
11H	command ID (RQ1)
aaH	address MSB
bbH	address
ccH	address
ddH	address LSB
ssH	size MSB
ttH	size
uuH	size
vvH	size LSB
sum	checksum
F7H	EOX (End Of Exclusive)

- * The size of data that can be transmitted at one time is fixed for each type of data, and data requests must be made with a fixed starting address and size. Refer to the address and size given in "Parameter Address Map" (p. 190).
- * For the checksum, refer to (p. 204).
- * This message is not received if the Rx.Exc parameter (SYSTEM/MIDI/SYS-EXC MIDI) is OFF.
- * This message is not received in GM mode.

○ Data Set 1 DT1

This message transmits the actual data, and is used when you wish to set the data of the receiving device.

status	data byte	status
F0H	41H, dev, 6AH, 12H, aaH, bbH, ccH, ddH, eeH, ... ffH, sum	F7H

Byte	Remarks
F0H	Exclusive status
41H	ID number (Roland)
dev	device ID (dev: 10H - 1FH)
6AH	model ID (XP-30)
12H	command ID (DT1)
aaH	address MSB
bbH	address
ccH	address
ddH	address LSB
eeH	data: The actual data to be transmitted. Multi-byte data is transmitted in the order of the address.
:	:
ffH	data
sum	checksum
F7H	EOX (End Of Exclusive)

- * The amount of data that is transmitted at one time is fixed for the type of data, and only data of the fixed starting address and size will be transmitted. Refer to the address and size given in "Parameter Address Map" (p. 190).
- * Data whose size is greater than 128 bytes should be divided into packets of 128 bytes or less and transmitted. Successive "Data Set 1" messages should have at least 20 ms of time interval between them.
- * For the checksum, refer to (p. 204).
- * This message is not received if Rx.Exc parameter (SYSTEM/MIDI/SYS-EXC MIDI) is OFF.
- * This message is not received in GM mode.

This device is able to receive GS Exclusive messages only for Scale Tune settings.

○ Data Set 1 DT1

This message transmits the actual data, and is used when you wish to set the data of the receiving device.

status	data byte	status
F0H	41H, dev, 42H, 12H, aaH, bbH, ccH, ddH, ... eeH, sum	F7H

Byte	Remarks
F0H	Exclusive status
41H	ID number (Roland)
dev	device ID (dev: 10H - 1FH)
42H	model ID (GS)
12H	command ID (DT1)
aaH	address MSB
bbH	address middle byte
ccH	address LSB
ddH	data: The actual data to be transmitted. Multi-byte data is transmitted in the address order.
:	:
eeH	data
sum	checksum
F7H	EOX (End Of Exclusive)

- * This message is not received when the Rx.Exc parameter (SYSTEM/MIDI/SYS-EXC MIDI) is OFF.
- * This message is not received in GM mode.

2. Data transmission (sound source section)

■ Channel Voice Messages

● Note Off

<u>status</u>	<u>2nd byte</u>	<u>3rd byte</u>
8nH	kkH	vvH
n=MIDI channel:	0H - FH (ch.1 - ch.16)	
kk=Note Number:	00H - 7FH (0 - 127)	
vv=Note Off Velocity:	00H - 7FH (0 - 127)	

● Note On

<u>status</u>	<u>2nd byte</u>	<u>3rd byte</u>
9nH	kkH	vvH
n=MIDI channel number:	0H - FH (ch.1 - ch.16)	
kk=note number:	00H - 7FH (0 - 127)	
vv=Note On velocity:	01H - 7FH (1 - 127)	

● Control Change

* By selecting a controller number that corresponds to the setting of the Assign parameter (SYSTEM/CONTROL/CONTROL PEDAL) or each Assign parameter of C1-4 Slider (SYSTEM/CONTROL/ASSIGN), you can transmit any desired control change.

○Bank Select (Controller number 0,32)

<u>status</u>	<u>2nd byte</u>	<u>3rd byte</u>
BnH	00H	mmH
BnH	20H	llH
n=MIDI channel number:	0H - FH (ch.1 - ch.16)	
mm,ll=Bank number:	00 00H - 7F 7FH (bank.1 - bank.16384)	

* This message is not transmitted if Program parameter (SYSTEM/MIDI/TRANSMIT MIDI) or Bank Sel parameter (SYSTEM/MIDI/TRANSMIT MIDI) is OFF.

* For the Bank Select that corresponds to each Patch, refer to section 1.

* This message is not transmitted in GM mode

○Modulation (Controller number 1)

<u>status</u>	<u>2nd byte</u>	<u>3rd byte</u>
BnH	01H	vvH
n=MIDI channel number:	0H - FH (ch.1 - ch.16)	
vv=Modulation Depth:	00H - 7FH (0 - 127)	

○Breath type (Controller number 2)

<u>status</u>	<u>2nd byte</u>	<u>3rd byte</u>
BnH	02H	vvH
n=MIDI channel number:	0H - FH (ch.1 - ch.16)	
vv=control value:	00H - 7FH (0 - 127)	

○Foot Type (Controller number 4)

<u>status</u>	<u>2nd byte</u>	<u>3rd byte</u>
BnH	04H	vvH
n=MIDI channel number:	0H - FH (ch.1 - ch.16)	
vv=control value:	00H - 7FH (0 - 127)	

○Portamento Time (Controller number 5)

<u>status</u>	<u>2nd byte</u>	<u>3rd byte</u>
BnH	05H	vvH
n=MIDI channel number:	0H - FH (ch.1 - ch.16)	
vv=Portamento Time:	00H - 7FH (0 - 127)	

○Volume (Controller number 7)

<u>status</u>	<u>2nd byte</u>	<u>3rd byte</u>
BnH	07H	vvH
n=MIDI channel number:	0H - FH (ch.1 - ch.16)	
vv=Volume:	00H - 7FH (0 - 127)	

○Balance (Controller number 8)

<u>status</u>	<u>2nd byte</u>	<u>3rd byte</u>
BnH	08H	vvH
n=MIDI channel number:	0H - FH (ch.1 - ch.16)	
vv=Balance:	00H - 7FH (0 - 127)	

○Panpot (Controller number 10)

<u>status</u>	<u>2nd byte</u>	<u>3rd byte</u>
BnH	0AH	vvH
n=MIDI channel number:	0H - FH (ch.1 - ch.16)	
vv=panpot:	00H - 40H - 7FH (left - center - right)	

○Expression (Controller number 11)

<u>status</u>	<u>2nd byte</u>	<u>3rd byte</u>
BnH	0BH	vvH
n=MIDI channel number:	0H - FH (ch.1 - ch.16)	
vv=Expression:	00H - 7FH (0 - 127)	

○Hold 1 (Controller number 64)

<u>status</u>	<u>2nd byte</u>	<u>3rd byte</u>
BnH	40H	vvH
n=MIDI channel number:	0H - FH (ch.1 - ch.16)	
vv=control value:	00H - 7FH (0 - 127) 0-63=OFF, 64-127=ON	

○Portamento (Controller number 65)

<u>status</u>	<u>2nd byte</u>	<u>3rd byte</u>
BnH	41H	vvH
n=MIDI channel number:	0H - FH (ch.1 - ch.16)	
vv=control value:	00H - 7FH (0 - 127) 0-63=OFF, 64-127=ON	

○Sostenuto (Controller number 66)

<u>status</u>	<u>2nd byte</u>	<u>3rd byte</u>
BnH	42H	vvH
n=MIDI channel number:	0H - FH (ch.1 - ch.16)	
vv=control value:	00H - 7FH (0 - 127) 0-63=OFF, 64-127=ON	

○Soft (Controller number 67)

<u>status</u>	<u>2nd byte</u>	<u>3rd byte</u>
BnH	43H	vvH
n=MIDI channel number:	0H - FH (ch.1 - ch.16)	
vv=control value:	00H - 7FH (0 - 127) 0-63=OFF, 64-127=ON	

○ Hold 2 (Controller number 69)

<u>status</u>	<u>2nd byte</u>	<u>3rd byte</u>
BnH	45H	vvH
n=MIDI channel number:	0H - FH (ch.1 - ch.16)	
vv=control value:	00H - 7FH (0 - 127)	

○Sound Controller 2 (Controller number 71)

<u>status</u>	<u>2nd byte</u>	<u>3rd byte</u>
BnH	47H	vvH
n=MIDI channel number:	0H - FH (ch.1 - ch.16)	
vv=control value:	00H - 40H - 7FH (-128 - 0 - +126)	

○Sound Controller 3 (Controller number 72)

<u>status</u>	<u>2nd byte</u>	<u>3rd byte</u>
BnH	48H	vvH
n=MIDI channel number:	0H - FH (ch.1 - ch.16)	
vv=control value:	00H - 40H - 7FH (-128 - 0 - +126)	

○Sound Controller 4 (Controller number 73)

<u>status</u>	<u>2nd byte</u>	<u>3rd byte</u>
BnH	49H	vvH
n=MIDI channel number:	0H - FH (ch.1 - ch.16)	
vv=control value:	00H - 40H - 7FH (-128 - 0 - +126)	

○Sound Controller 5 (Controller number 74)

<u>status</u>	<u>2nd byte</u>	<u>3rd byte</u>
BnH	4AH	vvH
n=MIDI channel number:	0H - FH (ch.1 - ch.16)	
vv=control value:	00H - 40H - 7FH (-64 - 0 - +63)	

○General Purpose Controller 5 (Controller number 80)

<u>status</u>	<u>2nd byte</u>	<u>3rd byte</u>
BnH	50H	vvH
n=MIDI channel number:	0H - FH (ch.1 - ch.16)	
vv=control value:	00H - 40H - 7FH (-128 - 0 - +126)	

○ General Purpose Controller 6 (Controller number 81)

<u>status</u>	<u>2nd byte</u>	<u>3rd byte</u>
BnH	51H	vvH
n=MIDI channel number:	0H - FH (ch.1 - ch.16)	
vv=control value:	00H - 40H - 7FH (-128 - 0 - +126)	

○ General Purpose Controller 7 (Controller number 82)

<u>status</u>	<u>2nd byte</u>	<u>3rd byte</u>
BnH	52H	vvH
n=MIDI channel number:	0H - FH (ch.1 - ch.16)	
vv=control value:	00H - 40H - 7FH (-128 - 0 - +126)	

○ General Purpose Controller 8 (Controller number 83)

<u>status</u>	<u>2nd byte</u>	<u>3rd byte</u>
BnH	53H	vvH
n=MIDI channel number:	0H - FH (ch.1 - ch.16)	
vv=control value:	00H - 40H - 7FH (-128 - 0 - +126)	

○ Portamento Control (Controller number 84)

<u>status</u>	<u>2nd byte</u>	<u>3rd byte</u>
BnH	54H	kkH
n=MIDI channel number:	0H - FH (ch.1 - ch.16)	
kk=source note number:	00H - 7FH (0 - 127)	

○ Effect 1 (Reverb Send Level) (Controller number 91)

<u>status</u>	<u>2nd byte</u>	<u>3rd byte</u>
BnH	5BH	vvH
n=MIDI channel number:	0H - FH (ch.1 - ch.16)	
vv=Reverb Send Level:	00H - 7FH (0 - 127)	

○ Effect 3 (Chorus Send Level) (Controller number 93)

<u>status</u>	<u>2nd byte</u>	<u>3rd byte</u>
BnH	5DH	vvH
n=MIDI channel:	0H - FH (ch.1 - ch.16)	
vv=Chorus Send Level:	00H - 7FH (0 - 127)	

○ RPN MSB/LSB (Controller number 100,101)

<u>status</u>	<u>2nd byte</u>	<u>3rd byte</u>
BnH	65H	mmH
BnH	64H	llH
n=MIDI channel number:	0H - FH (ch.1 - ch.16)	
mm=MSB of the parameter number specified by RPN		
ll=LSB of the parameter number specified by RPN		

This device transmits the following RPNs.

RPN	Data entry	Notes
<u>MSB LSB</u>	<u>MSB LSB</u>	
00H 00H	mmH -	Pitch Bend Sensitivity mm : 00H - 0CH (0 - 12 semitones) ll : 00H
00H 01H	mmH llH	Channel Fine Tuning mm, ll : 20 00H - 40 00H - 60 00H (-4096 x 100 / 8192 - 0 - +4096 x 100 / 8192 cent)
00H 02H	mmH -	Channel Coarse Tuning mm : 10H - 40H - 70H (-48 - 0 - +48 semitones) ll : 00H

● Program Change

<u>status</u>	<u>2nd byte</u>
CnH	ppH
n=MIDI channel:	0H - FH (ch.1 - ch.16)
pp=Program number:	00H - 7FH (prog.1 - prog.128)

* This message is not transmitted when the Program parameter (SYSTEM/MIDI/TRANSMIT MIDI) is OFF.

● Channel Aftertouch

<u>status</u>	<u>2nd byte</u>
DnH	vvH
n=MIDI channel:	0H - FH (ch.1 - ch.16)
vv=Channel Aftertouch:	00H - 7FH (1 - 128)

● Pitch Bend Change

<u>status</u>	<u>2nd byte</u>	<u>3rd byte</u>
EnH	llH	mmH
n=MIDI channel number:	0H - FH (ch.1 - ch.16)	
mm,ll=Pitch Bend value:	00 00H - 40 00H - 7F 7FH (-8192 - 0 - +8191)	

■ System Realtime Messages

● Active Sensing

status
FEH

* Transmitted at intervals of approximately 250ms.

* Not transmitted if the Active Sensing parameter (SYSTEM/MIDI/TRANSMIT MIDI) is OFF.

■ System Exclusive Messages

There is a kind of the Universal Non-realtime messages and the Data Set (DT1) messages in the System Exclusive messages transmitted by this device.

● Universal Non-realtime System Exclusive Messages

○ Identity Reply Message

When Identity Request message (p. 186) is received, this message will be transmitted.

<u>status</u>	<u>data byte</u>	<u>status</u>
F0H	7EH, dev, 06H, 02H, 41H, 6AH, 00H, 04H, 00H, 00H, 01H, 00H, 00H	F7H

Byte	Remarks
F0H	Exclusive status
7EH	ID number (Universal Non-realtime message)
dev	device ID (dev: 10H - 1FH)
06H	sub ID#1 (General Information)
02H	sub ID#2 (Identity Reply)
41H	ID number (Roland)
6AH 00H	Device family code
04H 00H	Device family number code
00H 01H 00H 00H	Software revision level
F7H	EOX (End Of Exclusive)

● Data Transmission

○ Data Set1 DT1

<u>status</u>	<u>data byte</u>	<u>status</u>
F0H	41H, dev, 6AH, 12H, aaH, bbH, ccH, ddH, eeH, ... ffH, sum	F7H

Byte	Remarks
F0H	Exclusive status
41H	ID number (Roland)
dev	device ID (dev: 10H - 1FH)
6AH	model ID (XP-30)
12H	command ID (DT1)
aaH	address MSB
bbH	address
ccH	address
ddH	address LSB
eeH	data: The actual data to be transmitted. Multi-byte data is transmitted in the address order.
:	:
ffH	data
sum	checksum
F7H	EOX (End Of Exclusive)

* The amount of data transmitted at one time is fixed for the type of data, and the data will be transmitted with the fixed starting address and size. Refer to the address and size given in "Parameter Address Map" (p. 190).

* Large amounts of data must be divided into packets of 128 bytes or less, and transmitted at intervals of approximately 20 ms.

* For the checksum, refer to (p. 204).

MIDI Implementation

3. Parameter Address Map

1. XP-30 (Model ID=6AH)

* For addresses marked by a #, the data must be divided into 2 parts for transmission. For example, data with the hexadecimal value ABH would be divided into 0AH and 0BH, and transmitted in that order.

* Parameter values enclosed in <> are for the JV-1010 / JV-1080 / JV-2080 / XP-50 / XP-60 / XP-80, and will be ignored if received by the XP-30.

Start Address	Description	
00 00 00 00	System	1-1
01 00 00 00	Temporary Performance	1-2
02 00 00 00	Performance Mode Temporary Patch(part 1)	1-3
02 01 00 00	Performance Mode Temporary Patch(part 2)	:
:	:	:
02 08 00 00	Performance Mode Temporary Patch(part 9)	:
02 09 00 00	Temporary Rhythm Setup	1-4
02 0A 00 00	Performance Mode Temporary Patch(part 11)	1-3
:	:	:
02 0F 00 00	Performance Mode Temporary Patch(part 16)	:
03 00 00 00	Patch Mode Temporary Patch	1-3
10 00 00 00	User Performance USER:01	1-2
10 01 00 00	User Performance USER:02	:
:	:	:
10 1F 00 00	User Performance USER:32	:
10 40 00 00	User Rhythm Setup USER:1	1-4
10 41 00 00	User Rhythm Setup USER:2	:
11 00 00 00	User Patch USER:001	1-3
11 01 00 00	User Patch USER:002	:
:	:	:
11 7F 00 00	User Patch USER:128	:

● 1-1.System

Offset Address	Description	
00 00	System Common	1-1-1
10 00	Part 1 Scale Tune	1-1-2
11 00	Part 2 Scale Tune	:
:	:	:
1F 00	Part 16 Scale Tune	:
20 00	Patch Mode Scale Tune	1-1-2

● 1-1-1.System Common

Offset Address	Size	Description	Data (Value)
00 00	0000 00aa	Sound Mode	0 - 2 *1
00 01	0aaa aaaa	Performance Number	0 - 127 *2
00 02	0000 00aa	Patch Group Type	0 - 2 *3 -->
00 03	0aaa aaaa	Patch Group ID	0 - 127 -->
# 00 04	0000 aaaa	Patch Number	0 - 255 -->
	0000 bbbb		(001 - 256)
00 06	0aaa aaaa	Master Tune	0 - 126 *4
00 07	0000 000a	Scale Tune Switch	0 - 1 (OFF, ON)
00 08	0000 000a	EFX Switch	0 - 1 (OFF, ON)
00 09	0000 000a	Chorus Switch	0 - 1 (OFF, ON)
00 0A	0000 000a	Reverb Switch	0 - 1 (OFF, ON)
00 0B	0000 000a	Patch Remain	0 - 1 (OFF, ON)
00 0C	0000 000a	Clock Source	0 - 1 (INT, MIDI)
00 0D	0000 0aaa	TAP Control Source	0 - 4 *5
00 0E	0000 0aaa	Hold Control Source	0 - 4 *6
00 0F	0000 0aaa	Peak Control Source	0 - 4 *6
00 10	0000 000a	Volume Control Source	0 - 1 *7
00 11	0000 00aa	Aftertouch Source	0 - 2 *8
00 12	0aaa aaaa	System Control Source 1	1 - 97 *9
00 13	0aaa aaaa	System Control Source 2	1 - 97 *9
00 14	0000 000a	Receive Program Change	0 - 1 (OFF, ON)
00 15	0000 000a	Receive Bank Select	0 - 1 (OFF, ON)
00 16	0000 000a	Receive Control Change	0 - 1 (<OFF, ON>)
00 17	0000 000a	Receive Modulation	0 - 1 (<OFF, ON>)
00 18	0000 000a	Receive Volume	0 - 1 (<OFF, ON>)
00 19	0000 000a	Receive Hold-1	0 - 1 (<OFF, ON>)
00 1A	0000 000a	Receive Pitch Bend	0 - 1 (<OFF, ON>)
00 1B	0000 000a	Receive Aftertouch	0 - 1 (<OFF, ON>)
00 1C	000a aaaa	Control Channel	0 - 16 (1 - 16, OFF)
00 1D	0000 aaaa	Patch Receive Channel	0 - 15 (1 - 16)
00 1E	0000 000a	Rhythm Edit Source	0 - 1 *10
00 1F	0000 00aa	Preview Sound Mode	0 - 2 *11
00 20	0aaa aaaa	Preview Note Set 1	0 - 127 (C-1 - G9)
00 21	0aaa aaaa	Preview Velocity Set 1	0 - 127 *12
00 22	0aaa aaaa	Preview Note Set 2	0 - 127 (C-1 - G9)
00 23	0aaa aaaa	Preview Velocity Set 2	0 - 127 *12
00 24	0aaa aaaa	Preview Note Set 3	0 - 127 (C-1 - G9)
00 25	0aaa aaaa	Preview Velocity Set 3	0 - 127 *12
00 26	0aaa aaaa	Preview Note Set 4	0 - 127 (C-1 - G9)
00 27	0aaa aaaa	Preview Velocity Set 4	0 - 127 *12
00 28	0000 000a	Transmit Program Change	0 - 1 (OFF, ON)
00 29	0000 000a	Transmit Bank Select	0 - 1 (OFF, ON)
00 2A	000a aaaa	Patch Transmit Channel	0 - 17 *13
00 2B	0000 000a	Transpose Switch	0 - 1 (OFF, ON)
00 2C	0000 aaaa	Transpose Value	0 - 11 (-5 - +6)
00 2D	0000 0aaa	Octave Shift	0 - 6 (-3 - +3)
00 2E	0aaa aaaa	Keyboard Velocity	0 - 127 *14
00 2F	0000 00aa	Keyboard Sens	0 - 2 *15
00 30	0aaa aaaa	Aftertouch Sens	0 - 100
00 31	0aaa aaaa	Pedal(1) Assign	1 - 104 *16
00 32	0000 00aa	Pedal(1) Output Mode	0 - 3 *18

Patch Group	Group Type	Group ID	Number (value)
USER	0	1	0 - 127 (001 - 128)
<CARD	0	2	0 - 127 (001 - 128) >
PR-A	0	3	0 - 127 (001 - 128)
PR-B	0	4	0 - 127 (001 - 128)
PR-C	0	5	0 - 127 (001 - 128)
PR-D	0	6	0 - 127 (001 - 128)
PR-E	0	7	0 - 127 (001 - 128)
<PCM	1	1 - 127	0 - 127 (001 - 128) >
XP-A(Session)	2	9	0 - 254 (001 - 255)
XP-B(Orch.)	2	2	0 - 254 (001 - 255)
XP-C(Techno)	2	11	0 - 255 (001 - 256)
XP-D	2	1 - 127	0 - 255 (001 - 256)
XP-E	2	1 - 127	0 - 255 (001 - 256)

00 33	0000 000a	Pedal(1) Polarity	0 - 1	*20
00 34	0aaa aaaa	Pedal2 Assign	1 - 104	*17
00 35	0000 00aa	Pedal2 Output Mode	0 - 3	*19
00 36	0000 000a	Pedal2 Polarity	0 - 1	*21
00 37	0aaa aaaa	C1 Assign	1 - 97	*9
00 38	0000 00aa	C1 Output Mode	0 - 3	*18
00 39	0aaa aaaa	C2 Assign	1 - 97	*9
00 3A	0000 00aa	C2 Output Mode	0 - 3	*18
00 3B	0000 00aa	Hold Pedal Output Mode	0 - 3	*18
00 3C	0000 000a	Hold Pedal Polarity	0 - 1	*20
<hr/>				
00 3D	0000 000a	Bank Select Group1 Switch	0 - 1	(OFF,ON)
00 3E	0aaa aaaa	Bank Select Group1 MSB	0 - 127	
00 3F	0aaa aaaa	Bank Select Group1 LSB	0 - 127	
00 40	0000 000a	Bank Select Group2 Switch	0 - 1	(OFF,ON)
00 41	0aaa aaaa	Bank Select Group2 MSB	0 - 127	
00 42	0aaa aaaa	Bank Select Group2 LSB	0 - 127	
00 43	0000 000a	Bank Select Group3 Switch	0 - 1	(OFF,ON)
00 44	0aaa aaaa	Bank Select Group3 MSB	0 - 127	
00 45	0aaa aaaa	Bank Select Group3 LSB	0 - 127	
00 46	0000 000a	Bank Select Group4 Switch	0 - 1	(OFF,ON)
00 47	0aaa aaaa	Bank Select Group4 MSB	0 - 127	
00 48	0aaa aaaa	Bank Select Group4 LSB	0 - 127	
00 49	0000 000a	Bank Select Group5 Switch	0 - 1	(OFF,ON)
00 4A	0aaa aaaa	Bank Select Group5 MSB	0 - 127	
00 4B	0aaa aaaa	Bank Select Group5 LSB	0 - 127	
00 4C	0000 000a	Bank Select Group6 Switch	0 - 1	(OFF,ON)
00 4D	0aaa aaaa	Bank Select Group6 MSB	0 - 127	
00 4E	0aaa aaaa	Bank Select Group6 LSB	0 - 127	
00 4F	0000 000a	Bank Select Group7 Switch	0 - 1	(OFF,ON)
00 50	0aaa aaaa	Bank Select Group7 MSB	0 - 127	
00 51	0aaa aaaa	Bank Select Group7 LSB	0 - 127	
<hr/>				
00 52	0aaa aaaa	Pedal3 Assign	1 - 104	*17
00 53	0000 00aa	Pedal3 Output Mode	0 - 3	*19
00 54	0000 000a	Pedal3 Polarity	0 - 1	*21
00 55	0aaa aaaa	Pedal4 Assign	1 - 104	*17
00 56	0000 00aa	Pedal4 Output Mode	0 - 3	*19
00 57	0000 000a	Pedal4 Polarity	0 - 1	*21
<hr/>				
00 58	00aa aaaa	Arpeggio Style	0 - 42	(1 - 43)
00 59	00aa aaaa	Arpeggio Motif	0 - 37	(1 - 38)
00 5A	0aaa aaaa	Arpeggio Beat Pattern	0 - 114	(1 - 115)
00 5B	0aaa aaaa	Arpeggio Accent Rate	0 - 100	
00 5C	0aaa aaaa	Arpeggio Shuffle Rate	50 - 90	
00 5D	0aaa aaaa	Arpeggio Keyboard Velocity	0 - 127	*14
00 5E	0000 0aaa	Arpeggio Octave Range	0 - 6	(-3 - +3)
00 5F	0000 aaaa	Arpeggio Part Number	0 - 15	*22
<hr/>				
#	00 60	0000 aaaa 0000 bbbb	System Tempo	20 - 250
<hr/>				
	00 62	0aaa aaaa	C3 Assign	1 - 97 *9
	00 63	0000 00aa	C3 Output Mode	0 - 3 *18
	00 64	0aaa aaaa	C4 Assign	1 - 97 *9
	00 65	0000 00aa	C4 Output Mode	0 - 3 *18
<hr/>				
Total size	00 00 00 66			

- *1 PERFORMANCE, PATCH, GM
- *2 USER:01-USER:32, <CARD:01-CARD:32>, PR-A:01-PR-A:32, PR-B:01-PR-B:32
- *3 USER&PRESET, <PCM>, EXP
- *4 427.4-452.6
- *5 <OFF, HOLD-1, SOSTENUTO, SOFT, HOLD-2>
- *6 OFF, HOLD-1, SOSTENUTO, SOFT, HOLD-2
- *7 VOLUME, VOLUME&EXPRESSION
- *8 CHANNEL, POLY, CH&POLY
- *9 CC01-CC05, CC07-CC31, CC64-CC95, PITCH BEND, AFTERTOUC
- *10 <PANEL, PANEL&MIDI>
- *11 SINGLE, CHORD, PHRASE
- *12 OFF, 1-127
- *13 1-16, RX-CH, OFF
- *14 REAL, 1-127
- *15 LIGHT, MEDIUM, HEAVY
- *16 CC01-CC05, CC07-CC31, CC64-CC95, PITCH BEND, AFTERTOUC, PROG-UP, PROG-DOWN, <START/STOP>, <PUNCH-IN/OUT>, TAP-TEMPO, OCTAVE-UP, OCTAVE-DOWN
- *17 <CC01-CC05, CC07-CC31, CC64-CC95, PITCH BEND, AFTERTOUC, PROG-UP, PROG-DOWN, <START/STOP>, <PUNCH-IN/OUT>, TAP-TEMPO, OCTAVE-UP, OCTAVE-DOWN>
- *18 OFF, INT, MIDI, INT&MIDI
- *19 <OFF, INT, MIDI, INT&MIDI>
- *20 STANDARD, REVERSE
- *21 <STANDARD, REVERSE>
- *22 PART1-PART16

● 1-1-2.Scale Tune

Offset	Address	Size	Description	Data (Value)
	00 00	0aaa aaaa	Scale Tune for C	0 - 127 (-64 - +63)
	00 01	0aaa aaaa	Scale Tune for C#	0 - 127 (-64 - +63)
	00 02	0aaa aaaa	Scale Tune for D	0 - 127 (-64 - +63)
	00 03	0aaa aaaa	Scale Tune for D#	0 - 127 (-64 - +63)
	00 04	0aaa aaaa	Scale Tune for E	0 - 127 (-64 - +63)
	00 05	0aaa aaaa	Scale Tune for F	0 - 127 (-64 - +63)
	00 06	0aaa aaaa	Scale Tune for F#	0 - 127 (-64 - +63)
	00 07	0aaa aaaa	Scale Tune for G	0 - 127 (-64 - +63)
	00 08	0aaa aaaa	Scale Tune for G#	0 - 127 (-64 - +63)
	00 09	0aaa aaaa	Scale Tune for A	0 - 127 (-64 - +63)
	00 0A	0aaa aaaa	Scale Tune for A#	0 - 127 (-64 - +63)
	00 0B	0aaa aaaa	Scale Tune for B	0 - 127 (-64 - +63)
<hr/>				
Total size	00 00 00 0C			

MIDI Implementation

● 1-2.Performance

Offset Address	Description	
00 00	Performance Common	1-2-1
10 00	Performance Part 1	1-2-2
11 00	Performance Part 2	
:		
1F 00	Performance Part 16	

● 1-2-1.Performance Common

Offset Address	Size	Description	Data (Value)
00 00	0aaa aaaa	Performance Name 1	32 - 127
00 01	0aaa aaaa	Performance Name 2	32 - 127
00 02	0aaa aaaa	Performance Name 3	32 - 127
00 03	0aaa aaaa	Performance Name 4	32 - 127
00 04	0aaa aaaa	Performance Name 5	32 - 127
00 05	0aaa aaaa	Performance Name 6	32 - 127
00 06	0aaa aaaa	Performance Name 7	32 - 127
00 07	0aaa aaaa	Performance Name 8	32 - 127
00 08	0aaa aaaa	Performance Name 9	32 - 127
00 09	0aaa aaaa	Performance Name 10	32 - 127
00 0A	0aaa aaaa	Performance Name 11	32 - 127
00 0B	0aaa aaaa	Performance Name 12	32 - 127
00 0C	0000 aaaa	EFX Source	0 - 15 *1
00 0D	00aa aaaa	EFX Type	0 - 39 (1 - 40)
00 0E	0aaa aaaa	EFX Parameter 1	0 - 127
00 0F	0aaa aaaa	EFX Parameter 2	0 - 127
00 10	0aaa aaaa	EFX Parameter 3	0 - 127
00 11	0aaa aaaa	EFX Parameter 4	0 - 127
00 12	0aaa aaaa	EFX Parameter 5	0 - 127
00 13	0aaa aaaa	EFX Parameter 6	0 - 127
00 14	0aaa aaaa	EFX Parameter 7	0 - 127
00 15	0aaa aaaa	EFX Parameter 8	0 - 127
00 16	0aaa aaaa	EFX Parameter 9	0 - 127
00 17	0aaa aaaa	EFX Parameter 10	0 - 127
00 18	0aaa aaaa	EFX Parameter 11	0 - 127
00 19	0aaa aaaa	EFX Parameter 12	0 - 127
00 1A	0000 00aa	EFX Output Assign	0 - 2 *2
00 1B	0aaa aaaa	EFX Mix Out Send Level	0 - 127
00 1C	0aaa aaaa	EFX Chorus Send Level	0 - 127
00 1D	0aaa aaaa	EFX Reverb Send Level	0 - 127
00 1E	0000 aaaa	EFX Control Source 1	0 - 10 *3
00 1F	0aaa aaaa	EFX Control Depth 1	0 - 126 (-63 - +63)
00 20	0000 aaaa	EFX Control Source 2	0 - 10 *3
00 21	0aaa aaaa	EFX Control Depth 2	0 - 126 (-63 - +63)
00 22	0aaa aaaa	Chorus Level	0 - 127
00 23	0aaa aaaa	Chorus Rate	0 - 127
00 24	0aaa aaaa	Chorus Depth	0 - 127
00 25	0aaa aaaa	Chorus Pre-Delay	0 - 127
00 26	0aaa aaaa	Chorus Feedback	0 - 127
00 27	0000 00aa	Chorus Output	0 - 2 *4
00 28	0000 0aaa	Reverb Type	0 - 7 *5
00 29	0aaa aaaa	Reverb Level	0 - 127
00 2A	0aaa aaaa	Reverb Time	0 - 127
00 2B	000a aaaa	Reverb HF Damp	0 - 17 *6
00 2C	0aaa aaaa	Delay Feedback	0 - 127
# 00 2D	0000 aaaa	Performance Tempo	20 - 250
00 2F	0000 000a	Keyboard Range Switch	0 - 1 (OFF,ON)
00 30	0aaa aaaa	Voice Reserve 1	0 - 64
00 31	0aaa aaaa	Voice Reserve 2	0 - 64
00 32	0aaa aaaa	Voice Reserve 3	0 - 64
00 33	0aaa aaaa	Voice Reserve 4	0 - 64
00 34	0aaa aaaa	Voice Reserve 5	0 - 64
00 35	0aaa aaaa	Voice Reserve 6	0 - 64
00 36	0aaa aaaa	Voice Reserve 7	0 - 64
00 37	0aaa aaaa	Voice Reserve 8	0 - 64
00 38	0aaa aaaa	Voice Reserve 9	0 - 64
00 39	0aaa aaaa	Voice Reserve 10	0 - 64
00 3A	0aaa aaaa	Voice Reserve 11	0 - 64
00 3B	0aaa aaaa	Voice Reserve 12	0 - 64
00 3C	0aaa aaaa	Voice Reserve 13	0 - 64
00 3D	0aaa aaaa	Voice Reserve 14	0 - 64
00 3E	0aaa aaaa	Voice Reserve 15	0 - 64
00 3F	0aaa aaaa	Voice Reserve 16	0 - 64
00 40	0000 000a	Keyboard Mode	0 - 1 *7
00 41	0000 000a	Clock Source	0 - 1 *8
Total size	00 00 00 42		

*1 PERFORM, 1-9, 11-16

*2 MIX, <DIRECT-1>, <DIRECT-2>

*3 OFF, SYS-CTRL1, SYS-CTRL2, MODULATION, BREATH, FOOT, VOLUME, PAN, EXPRESSION, PITCH BEND, AFTERTOUCH

*4 MIX, REV, MIX+REV

*5 ROOM1, ROOM2, STAGE1, STAGE2, HALL1, HALL2, DELAY, PAN-DLY

*6 200, 250, 315, 400, 500, 630, 800, 1000, 1250, 1600, 2000, 2500, 3150, 4000, 5000, 6300, 8000, BYPASS

*7 LAYER, SINGLE

*8 PERFORMANCE, SYSTEM

● 1-2-2. Performance Part

Offset Address	Size	Description	Data (Value)
00 00	0000 000a	Receive Switch	0 - 1 (OFF,ON)
00 01	0000 aaaa	MIDI Channel	0 - 15 (1 - 16)
# 00 02	0000 00aa	Patch Group Type	0 - 2 *1 ->
00 03	0aaa aaaa	Patch Group ID	0 - 127 ->
00 04	0000 aaaa	Patch Number	0 - 255 ->
	0000 bbbb		(001 - 256)
00 06	0aaa aaaa	Part Level	0 - 127
00 07	0aaa aaaa	Part Pan	0 - 127 (L64 - 63R)
00 08	0aaa aaaa	Part Coarse Tune	0 - 96 (-48 - +48)
00 09	0aaa aaaa	Part Fine Tune	0 - 100 (-50 - +50)
00 0A	0000 0aaa	Output Assign	0 - 4 *2
00 0B	0aaa aaaa	Mix/EFX Send Level	0 - 127
00 0C	0aaa aaaa	Chorus Send Level	0 - 127
00 0D	0aaa aaaa	Reverb Send Level	0 - 127
00 0E	0000 000a	Receive Program Change Switch	0 - 1 (OFF,ON)
00 0F	0000 000a	Receive Volume Switch	0 - 1 (OFF,ON)
00 10	0000 000a	Receive Hold-1 Switch	0 - 1 (OFF,ON)
00 11	0aaa aaaa	Keyboard Range Lower	0 - 127 *3
00 12	0aaa aaaa	Keyboard Range Upper	0 - 127 *4
00 13	0000 0aaa	Octave Shift	0 - 6 (-3 - +3)
00 14	0000 000a	Local Switch	0 - 1 (OFF,ON)
00 15	0000 000a	Transmit Switch	0 - 1 (OFF,ON)
00 16	0000 0aaa	Transmit Bank Select Group	0 - 7 *5
# 00 17	0000 aaaa	Transmit Volume	0 - 128
	0000 bbbb		(0 - 127,OFF)
Total size	00 00 00 19		

Patch Group	Group Type	Group ID	Number (value)
USER	0	1	0 - 127 (001 - 128)
<CARD	0	2	0 - 127 (001 - 128)>
PR-A	0	3	0 - 127 (001 - 128)
PR-B	0	4	0 - 127 (001 - 128)
PR-C	0	5	0 - 127 (001 - 128)
PR-D	0	6	0 - 127 (001 - 128)
PR-E	0	7	0 - 127 (001 - 128)
<PCM	1	1 - 127	0 - 127 (001 - 128)>
XP-A(Session)	2	9	0 - 254 (001 - 255)
XP-B(Orch.)	2	2	0 - 254 (001 - 255)
XP-C(Techno)	2	11	0 - 255 (001 - 256)
XP-D	2	1 - 127	0 - 255 (001 - 256)
XP-E	2	1 - 127	0 - 255 (001 - 256)

- *1 USER&PRESET, <PCM>, EXP
- *2 MIX, EFX, <DIRECT-1>, <DIRECT-2>, PATCH
- *3 C-1-Upper
- *4 Lower-G9
- *5 PATCH, GROUP1-GROUP7

● 1-3. Patch

Offset Address	Description
00 00	Patch Common 1-3-1
10 00	Patch Tone 1 1-3-2
12 00	Patch Tone 2
14 00	Patch Tone 3
16 00	Patch Tone 4

● 1-3-1. Patch Common

Offset Address	Size	Description	Data (Value)
00 00	0aaa aaaa	Patch Name 1	32 - 127
00 01	0aaa aaaa	Patch Name 2	32 - 127
00 02	0aaa aaaa	Patch Name 3	32 - 127
00 03	0aaa aaaa	Patch Name 4	32 - 127
00 04	0aaa aaaa	Patch Name 5	32 - 127
00 05	0aaa aaaa	Patch Name 6	32 - 127
00 06	0aaa aaaa	Patch Name 7	32 - 127
00 07	0aaa aaaa	Patch Name 8	32 - 127
00 08	0aaa aaaa	Patch Name 9	32 - 127
00 09	0aaa aaaa	Patch Name 10	32 - 127
00 0A	0aaa aaaa	Patch Name 11	32 - 127
00 0B	0aaa aaaa	Patch Name 12	32 - 127
00 0C	00aa aaaa	EFX Type	0 - 39 (1 - 40)
00 0D	0aaa aaaa	EFX Parameter 1	0 - 127
00 0E	0aaa aaaa	EFX Parameter 2	0 - 127
00 0F	0aaa aaaa	EFX Parameter 3	0 - 127
00 10	0aaa aaaa	EFX Parameter 4	0 - 127
00 11	0aaa aaaa	EFX Parameter 5	0 - 127
00 12	0aaa aaaa	EFX Parameter 6	0 - 127
00 13	0aaa aaaa	EFX Parameter 7	0 - 127
00 14	0aaa aaaa	EFX Parameter 8	0 - 127
00 15	0aaa aaaa	EFX Parameter 9	0 - 127
00 16	0aaa aaaa	EFX Parameter 10	0 - 127
00 17	0aaa aaaa	EFX Parameter 11	0 - 127
00 18	0aaa aaaa	EFX Parameter 12	0 - 127
00 19	0000 00aa	EFX Output Assign	0 - 2 *1
00 1A	0aaa aaaa	EFX Mix Out Send Level	0 - 127
00 1B	0aaa aaaa	EFX Chorus Send Level	0 - 127
00 1C	0aaa aaaa	EFX Reverb Send Level	0 - 127
00 1D	0000 aaaa	EFX Control Source 1	0 - 10 *2
00 1E	0aaa aaaa	EFX Control Depth 1	0 - 126 (-63 - +63)
00 1F	0000 aaaa	EFX Control Source 2	0 - 10
00 20	0aaa aaaa	EFX Control Depth 2	0 - 126 (-63 - +63)
00 21	0aaa aaaa	Chorus Level	0 - 127
00 22	0aaa aaaa	Chorus Rate	0 - 127
00 23	0aaa aaaa	Chorus Depth	0 - 127
00 24	0aaa aaaa	Chorus Pre-Delay	0 - 127
00 25	0aaa aaaa	Chorus Feedback	0 - 127
00 26	0000 00aa	Chorus Output	0 - 2 *3
00 27	0000 0aaa	Reverb Type	0 - 7 *4
00 28	0aaa aaaa	Reverb Level	0 - 127
00 29	0aaa aaaa	Reverb Time	0 - 127
00 2A	000a aaaa	Reverb HF Damp	0 - 17 *5
00 2B	0aaa aaaa	Delay Feedback	0 - 127

MIDI Implementation

#	00 2C	0000 aaaa	Patch Tempo	20 - 250
		0000 bbbb		
	00 2E	0aaa aaaa	Patch Level	0 - 127
	00 2F	0aaa aaaa	Patch Pan	0 - 127 (L64 - 63R)
	00 30	0aaa aaaa	Analog Feel	0 - 127
	00 31	0000 aaaa	Bend Range Up	0 - 12
	00 32	00aa aaaa	Bend Range Down	0 - 48 (0 - -48)
	00 33	0000 000a	Key Assign Mode	0 - 1 (POLY, SOLO)
	00 34	0000 000a	Solo Legato	0 - 1 (OFF, ON)
	00 35	0000 000a	Portamento Switch	0 - 1 (OFF, ON)
	00 36	0000 000a	Portamento Mode	0 - 1 *6
	00 37	0000 000a	Portamento Type	0 - 1 (RATE, TIME)
	00 38	0000 000a	Portamento Start	0 - 1 *7
	00 39	0aaa aaaa	Portamento Time	0 - 127
	00 3A	0000 aaaa	Patch Control Source 2	0 - 15 *8
	00 3B	0000 aaaa	Patch Control Source 3	0 - 15 *8
	00 3C	0000 00aa	AFX Control Hold/Peak	0 - 2 *9
	00 3D	0000 00aa	Control 1 Hold/Peak	0 - 2 *9
	00 3E	0000 00aa	Control 2 Hold/Peak	0 - 2 *9
	00 3F	0000 00aa	Control 3 Hold/Peak	0 - 2 *9
	00 40	0000 000a	Velocity Range Switch	0 - 1 (OFF, ON)
	00 41	0000 0aaa	Octave Shift	0 - 6 (-3 - +3)
	00 42	0000 00aa	Stretch Tune Depth	0 - 3 (OFF, 1 - 3)
	00 43	0000 000a	Voice Priority	0 - 1 *10
	00 44	0000 aaaa	Structure Type 1&2	0 - 9 (1 - 10)
	00 45	0000 00aa	Booster 1&2	0 - 3 *11
	00 46	0000 aaaa	Structure Type 3&4	0 - 9 (1 - 10)
	00 47	0000 00aa	Booster 3&4	0 - 3 *11
	00 48	0000 000a	Clock Source	0 - 1 *12
	00 49	0aaa aaaa	Patch Category	0 - 127 *13
Total size	00 00 00 4A			

- *1 MIX, <DIRECT-1>, <DIRECT-2>
- *2 OFF, SYS-CTRL1, SYS-CTRL2, MODULATION, BREATH, FOOT, VOLUME, PAN, EXPRESSION, PITCH BEND, AFTERTOUCH
- *3 MIX, REV, MIX+REV
- *4 ROOM1, ROOM2, STAGE1, STAGE2, HALL1, HALL2, DELAY, PAN-DLY
- *5 200, 250, 315, 400, 500, 630, 800, 1000, 1250, 1600, 2000, 2500, 3150, 4000, 5000, 6300, 8000, BYPASS
- *6 NORMAL, LEGATO
- *7 PITCH, NOTE
- *8 OFF, SYS-CTRL1, SYS-CTRL2, MODULATION, BREATH, FOOT, VOLUME, PAN, EXPRESSION, PITCH BEND, AFTERTOUCH, LFO1, LFO2, VELOCITY, KEYFOLLOW, PLAYMATE
- *9 OFF, HOLD, PEAK
- *10 LAST, LOUDEST
- *11 0, +6, +12, +18
- *12 PATCH, SYSTEM
- *13 NO ASSIGN, AC.PIANO, EL.PIANO, KEYBOARDS, BELL, MALLET, ORGAN, ACCORDION, HARMONICA, AC.GUITAR, EL.GUITAR, DIST.GUITAR, BASS, SYNTH BASS, STRINGS, ORCHESTRA, HIT&STAB, WIND, FLUTE, AC.BRASS, SYNTH BRASS, SAX, HARD LEAD, SOFT LEAD, TECHNO SYNTH, PULSATING, SYNTH FX, OTHER SYNTH, BRIGHT PAD, SOFT PAD, VOX, PLUCKED, ETHNIC, FRETTEED, PERCUSSION, SOUND FX, BEAT&GROOVE, DRUMS, COMBINATION (0-38)

● 1-3-2.Patch Tone

Offset	Address	Size	Description	Data (Value)
	00 00	0000 000a	Tone Switch	0 - 1 (OFF, ON)
	00 01	0000 00aa	Wave Group Type	0 - 2 *1 -->
	00 02	0aaa aaaa	Wave Group ID	0 - 127 -->
#	00 03	0000 aaaa	Wave Number	0 - 254 -->
		0000 bbbb		(001 - 255)
	00 05	0000 00aa	Wave Gain	0 - 3 *2
	00 06	0000 000a	FXM Switch	0 - 1 (OFF, ON)
	00 07	0000 00aa	FXM Color	0 - 3 (1 - 4)
	00 08	0000 aaaa	FXM Depth	0 - 15 (1 - 16)
	00 09	0000 0aaa	Tone Delay Mode	0 - 7 *3
	00 0A	0aaa aaaa	Tone Delay Time	0 - 127
	00 0B	0aaa aaaa	Velocity Cross Fade	0 - 127
	00 0C	0aaa aaaa	Velocity Range Lower	1 - 127 *4
	00 0D	0aaa aaaa	Velocity Range Upper	1 - 127 *5
	00 0E	0aaa aaaa	Keyboard Range Lower	0 - 127 *6
	00 0F	0aaa aaaa	Keyboard Range Upper	0 - 127 *7
	00 10	0000 000a	Redamper Control Switch	0 - 1 (OFF, ON)
	00 11	0000 000a	Volume Control Switch	0 - 1 (OFF, ON)
	00 12	0000 000a	Hold-1 Control Switch	0 - 1 (OFF, ON)
	00 13	0000 000a	Pitch Bend Control Switch	0 - 1 (OFF, ON)
	00 14	0000 00aa	Pan Control Switch	0 - 2 *8
	00 15	000a aaaa	Controller 1 Destination 1	0 - 18 *9
	00 16	0aaa aaaa	Controller 1 Depth 1	0 - 126 (-63 - +63)
	00 17	000a aaaa	Controller 1 Destination 2	0 - 18 *9
	00 18	0aaa aaaa	Controller 1 Depth 2	0 - 126 (-63 - +63)
	00 19	000a aaaa	Controller 1 Destination 3	0 - 18 *9
	00 1A	0aaa aaaa	Controller 1 Depth 3	0 - 126 (-63 - +63)
	00 1B	000a aaaa	Controller 1 Destination 4	0 - 18 *9
	00 1C	0aaa aaaa	Controller 1 Depth 4	0 - 126 (-63 - +63)
	00 1D	000a aaaa	Controller 2 Destination 1	0 - 18 *9
	00 1E	0aaa aaaa	Controller 2 Depth 1	0 - 126 (-63 - +63)
	00 1F	000a aaaa	Controller 2 Destination 2	0 - 18 *9
	00 20	0aaa aaaa	Controller 2 Depth 2	0 - 126 (-63 - +63)
	00 21	000a aaaa	Controller 2 Destination 3	0 - 18 *9
	00 22	0aaa aaaa	Controller 2 Depth 3	0 - 126 (-63 - +63)
	00 23	000a aaaa	Controller 2 Destination 4	0 - 18 *9
	00 24	0aaa aaaa	Controller 2 Depth 4	0 - 126 (-63 - +63)
	00 25	000a aaaa	Controller 3 Destination 1	0 - 18 *9
	00 26	0aaa aaaa	Controller 3 Depth 1	0 - 126 (-63 - +63)
	00 27	000a aaaa	Controller 3 Destination 2	0 - 18 *9
	00 28	0aaa aaaa	Controller 3 Depth 2	0 - 126 (-63 - +63)
	00 29	000a aaaa	Controller 3 Destination 3	0 - 18 *9
	00 2A	0aaa aaaa	Controller 3 Depth 3	0 - 126 (-63 - +63)
	00 2B	000a aaaa	Controller 3 Destination 4	0 - 18 *9
	00 2C	0aaa aaaa	Controller 3 Depth 4	0 - 126 (-63 - +63)

Wave Group	Group Type	Group ID	Number (value)
INT-A	0	1	0 - 254 (001 - 255)
INT-B	0	2	0 - 192 (001 - 193)
<PCM	1	1 - 127	0 - 254 (001 - 255) >
XP-A(Session)	2	9	0 - 205 (001 - 206)
XP-B(Orch.)	2	2	0 - 173 (001 - 174)
XP-C(Techno)	2	11	0 - 254 (001 - 255)
XP-D	2	1 - 127	0 - 254 (001 - 255)
XP-E	2	1 - 127	0 - 254 (001 - 255)

00 2D	0000 0aaa	LFO1 Waveform	0 - 7	*10
00 2E	0000 000a	LFO1 Key Sync	0 - 1	(OFF, ON)
00 2F	0aaa aaaa	LFO1 Rate	0 - 127	
00 30	0000 0aaa	LFO1 Offset	0 - 4	*11
00 31	0aaa aaaa	LFO1 Delay Time	0 - 127	
00 32	0000 00aa	LFO1 Fade Mode	0 - 3	*12
00 33	0aaa aaaa	LFO1 Fade Time	0 - 127	
00 34	0000 00aa	LFO1 External Sync	0 - 2	*13
00 35	0000 0aaa	LFO2 Waveform	0 - 7	*10
00 36	0000 000a	LFO2 Key Sync	0 - 1	(OFF, ON)
00 37	0aaa aaaa	LFO2 Rate	0 - 127	
00 38	0000 0aaa	LFO2 Offset	0 - 4	*11
00 39	0aaa aaaa	LFO2 Delay Time	0 - 127	
00 3A	0000 00aa	LFO2 Fade Mode	0 - 3	*12
00 3B	0aaa aaaa	LFO2 Fade Time	0 - 127	
00 3C	0000 00aa	LFO2 External Sync	0 - 2	*13
00 3D	0aaa aaaa	Coarse Tune	0 - 96	(-48 - +48)
00 3E	0aaa aaaa	Fine Tune	0 - 100	(-50 - +50)
00 3F	000a aaaa	Random Pitch Depth	0 - 30	*14
00 40	0000 0aaa	Pitch Keyfollow	0 - 15	*15
00 41	000a aaaa	Pitch Envelope Depth	0 - 24	(-12 - +12)
00 42	0aaa aaaa	Pitch Envelope Velocity Sens	0 - 125	*16
00 43	0000 0aaa	Pitch Envelope Velocity Time1	0 - 14	*17
00 44	0000 0aaa	Pitch Envelope Velocity Time4	0 - 14	*17
00 45	0000 0aaa	Pitch Envelope Time Keyfollow	0 - 14	*17
00 46	0aaa aaaa	Pitch Envelope Time 1	0 - 127	
00 47	0aaa aaaa	Pitch Envelope Time 2	0 - 127	
00 48	0aaa aaaa	Pitch Envelope Time 3	0 - 127	
00 49	0aaa aaaa	Pitch Envelope Time 4	0 - 127	
00 4A	0aaa aaaa	Pitch Envelope Level 1	0 - 126	(-63 - +63)
00 4B	0aaa aaaa	Pitch Envelope Level 2	0 - 126	(-63 - +63)
00 4C	0aaa aaaa	Pitch Envelope Level 3	0 - 126	(-63 - +63)
00 4D	0aaa aaaa	Pitch Envelope Level 4	0 - 126	(-63 - +63)
00 4E	0aaa aaaa	Pitch LFO1 Depth	0 - 126	(-63 - +63)
00 4F	0aaa aaaa	Pitch LFO2 Depth	0 - 126	(-63 - +63)
00 50	0000 0aaa	Filter Type	0 - 4	*18
00 51	0aaa aaaa	Cutoff Frequency	0 - 127	
00 52	0000 0aaa	Cutoff Keyfollow	0 - 15	*15
00 53	0aaa aaaa	Resonance	0 - 127	
00 54	0aaa aaaa	Resonance Velocity Sens	0 - 125	*16
00 55	0aaa aaaa	Filter Envelope Depth	0 - 126	(-63 - +63)
00 56	0000 0aaa	Filter Envelope Velocity Curve	0 - 6	(1 - 7)
00 57	0aaa aaaa	Filter Envelope Velocity Sens	0 - 125	*16
00 58	0000 0aaa	Filter Envelope Velocity Time1	0 - 14	*17
00 59	0000 0aaa	Filter Envelope Velocity Time4	0 - 14	*17
00 5A	0000 0aaa	Filter Envelope Time Keyfollow	0 - 14	*17
00 5B	0aaa aaaa	Filter Envelope Time 1	0 - 127	
00 5C	0aaa aaaa	Filter Envelope Time 2	0 - 127	
00 5D	0aaa aaaa	Filter Envelope Time 3	0 - 127	
00 5E	0aaa aaaa	Filter Envelope Time 4	0 - 127	
00 5F	0aaa aaaa	Filter Envelope Level 1	0 - 127	
00 60	0aaa aaaa	Filter Envelope Level 2	0 - 127	
00 61	0aaa aaaa	Filter Envelope Level 3	0 - 127	
00 62	0aaa aaaa	Filter Envelope Level 4	0 - 127	
00 63	0aaa aaaa	Filter LFO1 Depth	0 - 126	(-63 - +63)
00 64	0aaa aaaa	Filter LFO2 Depth	0 - 126	(-63 - +63)
00 65	0aaa aaaa	Tone Level	0 - 127	
00 66	0000 00aa	Bias Direction	0 - 3	*19
00 67	0aaa aaaa	Bias Position	0 - 127	(C-1 - G9)
00 68	0000 0aaa	Bias Level	0 - 14	*17
00 69	0000 0aaa	Level Envelope Velocity Curve	0 - 6	(1 - 7)
00 6A	0aaa aaaa	Level Envelope Velocity Sens	0 - 125	*16
00 6B	0000 0aaa	Level Envelope Velocity Time1	0 - 14	*17
00 6C	0000 0aaa	Level Envelope Velocity Time4	0 - 14	*17
00 6D	0000 0aaa	Level Envelope Time Keyfollow	0 - 14	*17
00 6E	0aaa aaaa	Level Envelope Time 1	0 - 127	
00 6F	0aaa aaaa	Level Envelope Time 2	0 - 127	
00 70	0aaa aaaa	Level Envelope Time 3	0 - 127	
00 71	0aaa aaaa	Level Envelope Time 4	0 - 127	
00 72	0aaa aaaa	Level Envelope Level 1	0 - 127	
00 73	0aaa aaaa	Level Envelope Level 2	0 - 127	
00 74	0aaa aaaa	Level Envelope Level 3	0 - 127	
00 75	0aaa aaaa	Level LFO1 Depth	0 - 126	(-63 - +63)
00 76	0aaa aaaa	Level LFO2 Depth	0 - 126	(-63 - +63)
00 77	0aaa aaaa	Tone Pan	0 - 127	(L64 - 63R)
00 78	0000 0aaa	Pan KeyFollow	0 - 14	*17
00 79	00aa aaaa	Random Pan Depth	0 - 63	
00 7A	0aaa aaaa	Alternate Pan Depth	1 - 127	(L63 - 63R)
00 7B	0aaa aaaa	Pan LFO1 Depth	0 - 126	(L63 - 63R)
00 7C	0aaa aaaa	Pan LFO2 Depth	0 - 126	(L63 - 63R)
00 7D	0000 00aa	Output Assign	0 - 3	*20
00 7E	0aaa aaaa	Mix/EFX Send Level	0 - 127	
00 7F	0aaa aaaa	Chorus Send Level	0 - 127	
01 00	0aaa aaaa	Reverb Send Level	0 - 127	
Total size	00 00 01 01			

- *1 INT, <PCM>, EXP
- *2 -6, 0, +6, +12
- *3 NORMAL, HOLD, PLAYMATE, CLOCK-SYNC, <TAP-SYNC>, KEY-OFF-N, KEY-OFF-D, TEMPO-SYNC
- *4 1-Upper
- *5 Lower-127
- *6 C-1-Upper
- *7 Lower-G9
- *8 OFF, CONTINUOUS, KEY-ON
- *9 OFF, PCH, CUT, RES, LEV, PAN, MIX, CHO, REV, PL1, PL2, FL1, FL2, AL1, AL2, pL1, pL2, LIR, L2R
- *10 TRI, SIN, SAW, SQR, TRP, S&H, RND, CHS
- *11 -100, -50, 0, +50, +100
- *12 KEY-ON-IN, KEY-ON-OUT, KEY-OFF-IN, KEY-OFF-OUT
- *13 OFF, CLOCK, <TAP>
- *14 0, 1, 2, 3, 4, 5, 6, 7, 8, 9, 10, 20, 30, 40, 50, 60, 70, 80, 90, 100, 200, 300, 400, 500, 600, 700, 800, 900, 1000, 1100, 1200
- *15 -100, -70, -50, -30, -10, 0, +10, +20, +30, +40, +50, +70, +100, +120, +150, +200

MIDI Implementation

*16 -100+150

*17 -100, -70, -50, -40, -30, -20, -10, 0, +10, +20, +30, +40, +50, +70, +100

*18 OFF, LPF, BPF, HPF, PKG

*19 LOWER, UPPER, LOWER&UPPER, ALL

*20 MIX, EFX, <DIRECT-1>, <DIRECT-2>

1-4.Rhythm Setup

Offset Address	Description	
00 00	Rhythm Common	1-4-1
23 00	Rhythm Note for Key# 35	1-4-2
24 00	Rhythm Note for Key# 36	
:		
62 00	Rhythm Note for Key# 98	

1-4-1.Rhythm Common

Offset Address	Size	Description	Data (Value)
00 00	0aaa aaaa	Rhythm Name 1	32 - 127
00 01	0aaa aaaa	Rhythm Name 2	32 - 127
00 02	0aaa aaaa	Rhythm Name 3	32 - 127
00 03	0aaa aaaa	Rhythm Name 4	32 - 127
00 04	0aaa aaaa	Rhythm Name 5	32 - 127
00 05	0aaa aaaa	Rhythm Name 6	32 - 127
00 06	0aaa aaaa	Rhythm Name 7	32 - 127
00 07	0aaa aaaa	Rhythm Name 8	32 - 127
00 08	0aaa aaaa	Rhythm Name 9	32 - 127
00 09	0aaa aaaa	Rhythm Name 10	32 - 127
00 0A	0aaa aaaa	Rhythm Name 11	32 - 127
00 0B	0aaa aaaa	Rhythm Name 12	32 - 127
Total size	00 00 00 0C		

1-4-2.Rhythm Note

Offset Address	Size	Description	Data (Value)
00 00	0000 000a	Tone Switch	0 - 1 (OFF,ON)
00 01	0000 00aa	Wave Group Type	0 - 2 *1 ->
00 02	0aaa aaaa	Wave Group ID	0 - 127 ->
00 03	0000 aaaa	Wave Number	0 - 254 ->
	0000 bbbb		001 - 255)
00 05	0000 00aa	Wave Gain	0 - 3 *2
00 06	0000 aaaa	Bend Range	0 - 12
00 07	000a aaaa	Mute Group	0 - 31 (OFF,1 - 31)
00 08	0000 000a	Envelope Mode	0 - 1 *3
00 09	0000 000a	Volume Control Switch	0 - 1 (OFF,ON)
00 0A	0000 000a	Hold-1 Control Switch	0 - 1 (OFF,ON)
00 0B	0000 00aa	Pan Control Switch	0 - 2 *4
00 0C	0aaa aaaa	Coarse Tune	0 - 127 (C-1 - G9)
00 0D	0aaa aaaa	Fine Tune	0 - 100 (-50 - +50)
00 0E	000a aaaa	Random Pitch Depth	0 - 30 *5
00 0F	000a aaaa	Pitch Envelope Depth	0 - 24 (-12 - +12)
00 10	0aaa aaaa	Pitch Envelope Velocity Sens	0 - 125 *6
00 11	0000 aaaa	Pitch Envelope Velocity Time	0 - 14 *7
00 12	0aaa aaaa	Pitch Envelope Time 1	0 - 127
00 13	0aaa aaaa	Pitch Envelope Time 2	0 - 127
00 14	0aaa aaaa	Pitch Envelope Time 3	0 - 127
00 15	0aaa aaaa	Pitch Envelope Time 4	0 - 127
00 16	0aaa aaaa	Pitch Envelope Level 1	0 - 126 (-63 - +63)
00 17	0aaa aaaa	Pitch Envelope Level 2	0 - 126 (-63 - +63)
00 18	0aaa aaaa	Pitch Envelope Level 3	0 - 126 (-63 - +63)
00 19	0aaa aaaa	Pitch Envelope Level 4	0 - 126 (-63 - +63)
00 1A	0000 0aaa	Filter Type	0 - 4 *8
00 1B	0aaa aaaa	Cutoff Frequency	0 - 127
00 1C	0aaa aaaa	Resonance	0 - 127
00 1D	0aaa aaaa	Resonance Velocity Sens	0 - 125 *6
00 1E	0aaa aaaa	Filter Envelope Depth	0 - 126 (-63 - +63)
00 1F	0aaa aaaa	Filter Envelope Velocity Sens	0 - 125 *6
00 20	0000 aaaa	Filter Envelope Velocity Time	0 - 14 *7
00 21	0aaa aaaa	Filter Envelope Time 1	0 - 127
00 22	0aaa aaaa	Filter Envelope Time 2	0 - 127
00 23	0aaa aaaa	Filter Envelope Time 3	0 - 127
00 24	0aaa aaaa	Filter Envelope Time 4	0 - 127
00 25	0aaa aaaa	Filter Envelope Level 1	0 - 127
00 26	0aaa aaaa	Filter Envelope Level 2	0 - 127
00 27	0aaa aaaa	Filter Envelope Level 3	0 - 127
00 28	0aaa aaaa	Filter Envelope Level 4	0 - 127
00 29	0aaa aaaa	Tone Level	0 - 127
00 2A	0aaa aaaa	Level Envelope Velocity Sens	0 - 125 *6
00 2B	0000 aaaa	Level Envelope Velocity Time	0 - 14 *7
00 2C	0aaa aaaa	Level Envelope Time 1	0 - 127
00 2D	0aaa aaaa	Level Envelope Time 2	0 - 127
00 2E	0aaa aaaa	Level Envelope Time 3	0 - 127
00 2F	0aaa aaaa	Level Envelope Time 4	0 - 127
00 30	0aaa aaaa	Level Envelope Level 1	0 - 127
00 31	0aaa aaaa	Level Envelope Level 2	0 - 127
00 32	0aaa aaaa	Level Envelope Level 3	0 - 127
00 33	0aaa aaaa	Tone Pan	0 - 127 (L64 - 63R)
00 34	00aa aaaa	Random Pan Depth	0 - 63
00 35	0aaa aaaa	Alternate Pan Depth	1 - 127 (L63 - 63R)
00 36	0000 00aa	Output Assign	0 - 3 *9
00 37	0aaa aaaa	Mix/EFX Send Level	0 - 127
00 38	0aaa aaaa	Chorus Send Level	0 - 127
00 39	0aaa aaaa	Reverb Send Level	0 - 127
Total size	00 00 00 3A		

Wave Group	Group Type	Group ID	Number (value)
INT-A	0	1	0 - 254 (001 - 255)
INT-B	0	2	0 - 192 (001 - 193)
<PCM	1	1 - 127	0 - 254 (001 - 255)>
XP-A(Session)	2	9	0 - 205 (001 - 206)
XP-B(Orch.)	2	2	0 - 173 (001 - 174)
XP-C(Techno)	2	11	0 - 254 (001 - 255)
XP-D	2	1 - 127	0 - 254 (001 - 255)
XP-E	2	1 - 127	0 - 254 (001 - 255)

- *1 INT, <PCM>, EXP
- *2 -6, 0, +6, +12
- *3 NO-SUS, SUSTAIN
- *4 OFF, CONTINUOUS, KEY-ON
- *5 0, 1, 2, 3, 4, 5, 6, 7, 8, 9, 10, 20, 30, 40, 50, 60, 70, 80, 90, 100, 200, 300, 400, 500, 600, 700, 800, 900, 1000, 1100, 1200
- *6 -100+150
- *7 -100, -70, -50, -40, -30, -20, -10, 0, +10, +20, +30, +40, +50, +70, +100
- *8 OFF, LPF, BPF, HPF, PKG
- *9 MIX, EFX, <DIRECT-1>, <DIRECT-2>

■ Address Block Map

The following is an outline of the address map for Exclusive messages.

Address(H)	Block	Sub Block	Reference
00 00 00 00	System common		1-1-1
	Scale tune	Part 1	1-1-2
		:	
		Part 16	
		Patch	
01 00 00 00	Temporary performance	Common	1-2-1
		Part 1	1-2-2
		:	
		Part 16	
02 00 00 00	Performance mode temporary patch	Part 1	Common 1-3-1
		:	Tone 1 1-3-2
		Part 9	:
			Tone 4
02 09 00 00	Temporary rhythm setup	Common	1-4-1
		Note# 35	1-4-2
		:	
		Note# 98	
02 0A 00 00	Performance mode temporary patch	Part 11	Common 1-3-1
		:	Tone 1 1-3-2
		Part 16	:
			Tone 4
03 00 00 00	Patch mode temporary patch	Common	1-3-1
		Tone 1	1-3-2
		:	
		Tone 4	
10 00 00 00	User performance	USER:01	Common 1-2-1
		:	Part 1 1-2-2
		USER:32	:
			Part 16
10 40 00 00	User rhythm setup	USER:1	Common 1-4-1
		USER:2	Note# 35 1-4-2
		:	
			Note# 98
11 00 00 00	User patch	USER:001	Common 1-3-1
		:	Tone 1 1-3-2
		USER:128	:
			Tone 4

MIDI Implementation

2. GS (Model ID = 42H)

Start address	Description
40 10 00	Scale Tune Part10 2-1
40 11 00	: Part1
40 12 00	: Part2
40 13 00	: Part3
40 14 00	: Part4
40 15 00	: Part5
40 16 00	: Part6
40 17 00	: Part7
40 18 00	: Part8
40 19 00	: Part9
40 1A 00	: Part11
40 1B 00	: Part12
40 1C 00	: Part13
40 1D 00	: Part14
40 1E 00	: Part15
40 1F 00	: Part16

● 2-1.Scale Tune

Offset Address	Description
40	0aaa aaaa Scale Tune for C 0 - 127 (-64 - +63)
41	0aaa aaaa Scale Tune for C# 0 - 127 (-64 - +63)
42	0aaa aaaa Scale Tune for D 0 - 127 (-64 - +63)
43	0aaa aaaa Scale Tune for D# 0 - 127 (-64 - +63)
44	0aaa aaaa Scale Tune for E 0 - 127 (-64 - +63)
45	0aaa aaaa Scale Tune for F 0 - 127 (-64 - +63)
46	0aaa aaaa Scale Tune for F# 0 - 127 (-64 - +63)
47	0aaa aaaa Scale Tune for G 0 - 127 (-64 - +63)
48	0aaa aaaa Scale Tune for G# 0 - 127 (-64 - +63)
49	0aaa aaaa Scale Tune for A 0 - 127 (-64 - +63)
4A	0aaa aaaa Scale Tune for A# 0 - 127 (-64 - +63)
4B	0aaa aaaa Scale Tune for B 0 - 127 (-64 - +63)
Total Size	00 00 0C

* In order for a GS Exclusive message to be correctly received by the XP-30, the starting address of the message must be the Start address of each Part (the address of Scale Tune C, i.e., offset 40).

4. Supplementary Material

■ Correspondence of the EFX Algorithm and Exclusive Address (EFX Parameter 1–12)

EFX	Parameter	Value
-----	-----------	-------

● Type01: STEREO-EQ

prm1	Low Frequency	0 - 1
prm2	Low Gain	0 - 30
prm3	High Frequency	0 - 1
prm4	High Gain	0 - 30
prm5	Peaking1 Frequency	0 - 16
prm6	Peaking1 Q	0 - 4
prm7	Peaking1 Gain	0 - 30
prm8	Peaking2 Frequency	0 - 16
prm9	Peaking2 Q	0 - 4
prm10	Peaking2 Gain	0 - 30
prm11	Level	0 - 127

● Type02: OVERDRIVE

prm1	Drive	0 - 127
prm2	Output Pan	0 - 127
prm3	Amp Simulator Type	0 - 3
prm4	Low Gain	0 - 30
prm5	High Gain	0 - 30
prm6	Output Level	0 - 127

● Type03: DISTORTION

prm1	Drive	0 - 127
prm2	Output Pan	0 - 127
prm3	Amp Simulator Type	0 - 3
prm4	Low Gain	0 - 30
prm5	High Gain	0 - 30
prm6	Output Level	0 - 127

● Type04: PHASER

prm1	Manual	0 - 125
prm2	Rate	0 - 125
prm3	Depth	0 - 127
prm4	Resonance	0 - 127
prm5	Mix Level	0 - 127
prm6	Output Pan	0 - 127
prm7	Output Level	0 - 127

● Type05: SPECTRUM

prm1	Band1 Gain	0 - 30
prm2	Band2 Gain	0 - 30
prm3	Band3 Gain	0 - 30
prm4	Band4 Gain	0 - 30
prm5	Band5 Gain	0 - 30
prm6	Band6 Gain	0 - 30
prm7	Band7 Gain	0 - 30
prm8	Band8 Gain	0 - 30
prm9	Q	0 - 4
prm10	Output Pan	0 - 127
prm11	Output Level	0 - 127

● Type06: ENHANCER

prm1	Sens	0 - 127
prm2	Mix Level	0 - 127
prm3	Low Gain	0 - 30
prm4	High Gain	0 - 30
prm5	Output Level	0 - 127

● Type07: AUTO-WAH

prm1	Filter Type	0 - 1
prm2	Rate	0 - 125
prm3	Depth	0 - 127
prm4	Sens	0 - 127
prm5	Manual	0 - 127
prm6	Peak	0 - 127
prm7	Output Level	0 - 127

● Type08: ROTARY

prm1	High Frequency Slow Rate	0 - 125
prm2	Low Frequency Slow Rate	0 - 125
prm3	High Frequency Fast Rate	0 - 125
prm4	Low Frequency Fast Rate	0 - 125
prm5	Speed	0 - 1
prm6	High Frequency Acceleration	0 - 15
prm7	Low Frequency Acceleration	0 - 15
prm8	High Frequency Level	0 - 127
prm9	Low Frequency Level	0 - 127
prm10	Separation	0 - 127
prm11	Output Level	0 - 127

● Type09: COMPRESSOR

prm1	Sustain	0 - 127
prm2	Attack	0 - 127
prm3	Output Pan	0 - 127
prm4	Post Gain	0 - 3
prm5	Low Gain	0 - 30
prm6	High Gain	0 - 30
prm7	Output Level	0 - 127

● Type10: LIMITER

prm1	Threshold Level	0 - 127
prm2	Release Time	0 - 127
prm3	Compression Ratio	0 - 3
prm4	Output Pan	0 - 127
prm5	Post Gain	0 - 3
prm6	Low Gain	0 - 30
prm7	High Gain	0 - 30
prm8	Output Level	0 - 127

● Type11: HEXA-CHORUS

prm1	Pre Delay Time	0 - 125
prm2	Rate	0 - 125
prm3	Depth	0 - 127
prm4	Pre Delay Deviation	0 - 20
prm5	Depth Deviation	0 - 40
prm6	Pan Deviation	0 - 20
prm7	Effect Balance	0 - 100
prm8	Output Level	0 - 127

● Type12: TREMOLO-CHORUS

prm1	Pre Delay Time	0 - 125
prm2	Chorus Rate	0 - 125
prm3	Chorus Depth	0 - 127
prm4	Tremolo Rate	0 - 125
prm5	Tremolo Separation	0 - 127
prm6	Tremolo Phase	0 - 90
prm7	Effect Balance	0 - 100
prm8	Output Level	0 - 127

● Type13: SPACE-D

prm1	Pre Delay Time	0 - 125
prm2	Rate	0 - 125
prm3	Depth	0 - 127
prm4	Phase	0 - 90
prm5	Low Gain	0 - 30
prm6	High Gain	0 - 30
prm7	Effect Balance	0 - 100
prm8	Output Level	0 - 127

● Type14: STEREO-CHORUS

prm1	Filter Type	0 - 2
prm2	Cutoff Frequency	0 - 16
prm3	Pre Delay Time	0 - 125
prm4	Rate	0 - 125
prm5	Depth	0 - 127
prm6	Phase	0 - 90
prm7	(not used)	
prm8	Low Gain	0 - 30
prm9	High Gain	0 - 30
prm10	Effect Balance	0 - 100
prm11	Output Level	0 - 127

● Type15: STEREO-FLANGER

prm1	Filter Type	0 - 2
prm2	Cutoff Frequency	0 - 16
prm3	Pre Delay Time	0 - 125
prm4	Rate	0 - 125
prm5	Depth	0 - 127
prm6	Phase	0 - 90
prm7	Feedback Level	0 - 98
prm8	Low Gain	0 - 30
prm9	High Gain	0 - 30
prm10	Effect Balance	0 - 100
prm11	Output Level	0 - 127

● Type16: STEP-FLANGER

prm1	Pre Delay Time	0 - 125
prm2	Rate	0 - 125
prm3	Depth	0 - 127
prm4	Feedback Level	0 - 98
prm5	Step Rate	0 - 125
prm6	Phase	0 - 90
prm7	Low Gain	0 - 30
prm8	High Gain	0 - 30
prm9	Effect Balance	0 - 100
prm10	Output Level	0 - 127

MIDI Implementation

● Type17: STEREO-DELAY

prm1	Feedback Mode	0 - 1
prm2	Delay Time Left	0 - 126
prm3	Delay Time Right	0 - 126
prm4	Feedback Phase Left	0 - 1
prm5	Feedback Phase Right	0 - 1
prm6	Feedback Level	0 - 98
prm7	HF Damp	0 - 17
prm8	Low Gain	0 - 30
prm9	High Gain	0 - 30
prm10	Effect Balance	0 - 100
prm11	Output Level	0 - 127

● Type18: MODULATION-DELAY

prm1	Feedback Mode	0 - 1
prm2	Delay Time Left	0 - 126
prm3	Delay Time Right	0 - 126
prm4	Feedback Level	0 - 98
prm5	HF Damp	0 - 17
prm6	Rate	0 - 125
prm7	Depth	0 - 127
prm8	Phase	0 - 90
prm9	Low Gain	0 - 30
prm10	High Gain	0 - 30
prm11	Effect Balance	0 - 100
prm12	Output Level	0 - 127

● Type19: TRIPLE-TAP-DELAY

prm1	Delay Time Left	0 - 125
prm2	Delay Time Right	0 - 125
prm3	Delay Time Center	0 - 125
prm4	Feedback Level	0 - 98
prm5	HF Damp	0 - 17
prm6	Left Level	0 - 127
prm7	Right Level	0 - 127
prm8	Center Level	0 - 127
prm9	Low Gain	0 - 30
prm10	High Gain	0 - 30
prm11	Effect Balance	0 - 100
prm12	Output Level	0 - 127

● Type20: QUADRUPLE-TAP-DELAY

prm1	Delay Time 1	0 - 125
prm2	Delay Time 2	0 - 125
prm3	Delay Time 3	0 - 125
prm4	Delay Time 4	0 - 125
prm5	Level 1	0 - 127
prm6	Level 2	0 - 127
prm7	Level 3	0 - 127
prm8	Level 4	0 - 127
prm9	Feedback Level	0 - 98
prm10	HF Damp	0 - 17
prm11	Effect Balance	0 - 100
prm12	Output Level	0 - 127

● Type21: TIME-CONTROL-DELAY

prm1	Delay Time	0 - 120
prm2	Feedback Level	0 - 98
prm3	Acceleration	0 - 15
prm4	HF Damp	0 - 17
prm5	Output Pan	0 - 127
prm6	Low Gain	0 - 30
prm7	High Gain	0 - 30
prm8	Effect Balance	0 - 100
prm9	Output Level	0 - 127

● Type22: 2VOICE-PITCH-SHIFTER

prm1	Pitch Shifter Mode	0 - 4
prm2	Coarse Pitch A	0 - 36
prm3	Coarse Pitch B	0 - 36
prm4	Fine Pitch A	0 - 100
prm5	Fine Pitch B	0 - 100
prm6	Pre Delay Time A	0 - 126
prm7	Pre Delay Time B	0 - 126
prm8	Output Pan A	0 - 127
prm9	Output Pan B	0 - 127
prm10	Level Balance	0 - 100
prm11	Effect Balance	0 - 100
prm12	Output Level	0 - 127

● Type23: FBK-PITCH-SHIFTER

prm1	Pitch Shifter Mode	0 - 4
prm2	Coarse Pitch	0 - 36
prm3	Fine Pitch	0 - 100
prm4	Pre Delay Time	0 - 126
prm5	Feedback Level	0 - 98
prm6	Output Pan	0 - 127
prm7	Low Gain	0 - 30
prm8	High Gain	0 - 30
prm9	Effect Balance	0 - 100
prm10	Output Level	0 - 127

● Type24: REVERB

prm1	Reverb Type	0 - 5
prm2	Pre Delay Time	0 - 125
prm3	Gate Time	0 - 127
prm4	HF Damp	0 - 17
prm5	Low Gain	0 - 30
prm6	High Gain	0 - 30
prm7	Effect Balance	0 - 100
prm8	Output Level	0 - 127

● Type25: GATE-REVERB

prm1	Gate-Reverb Type	0 - 3
prm2	Pre Delay Time	0 - 125
prm3	Gate Time	0 - 99
prm4	Low Gain	0 - 30
prm5	High Gain	0 - 30
prm6	Effect Balance	0 - 100
prm7	Output Level	0 - 127

● Type26: OVERDRIVE→CHORUS

prm1	Drive	0 - 127
prm2	Over Drive Pan	0 - 127
prm3	Chorus Pre Delay Time	0 - 125
prm4	Chorus Rate	0 - 125
prm5	Chorus Depth	0 - 127
prm6	(not used)	
prm7	Chorus Balance	0 - 100
prm8	Output Level	0 - 127

● Type27: OVERDRIVE→FLANGER (serial)

prm1	Drive	0 - 127
prm2	Over Drive Pan	0 - 127
prm3	Flanger Pre Delay Time	0 - 125
prm4	Flanger Rate	0 - 125
prm5	Flanger Depth	0 - 127
prm6	Flanger Feedback Level	0 - 98
prm7	Flanger Balance	0 - 100
prm8	Output Level	0 - 127

● Type28: OVERDRIVE→DELAY (serial)

prm1	Drive	0 - 127
prm2	Over Drive Pan	0 - 127
prm3	Delay Time	0 - 126
prm4	Delay Feedback Level	0 - 98
prm5	Delay HF Damp	0 - 17
prm6	Delay Balance	0 - 100
prm7	Output Level	0 - 127

● Type29: DISTORTION→CHORUS (serial)

prm1	Distortion Drive	0 - 127
prm2	Distortion Pan	0 - 127
prm3	Chorus Pre Delay Time	0 - 125
prm4	Chorus Rate	0 - 125
prm5	Chorus Depth	0 - 127
prm6	(not used)	
prm7	Chorus Balance	0 - 100
prm8	Output Level	0 - 127

● Type30: DISTORTION→FLANGER (serial)

prm1	Distortion Drive	0 - 127
prm2	Distortion Pan	0 - 127
prm3	Flanger Pre Delay Time	0 - 125
prm4	Flanger Rate	0 - 125
prm5	Flanger Depth	0 - 127
prm6	Flanger Feedback Level	0 - 98
prm7	Flanger Balance	0 - 100
prm8	Output Level	0 - 127

● Type31: DISTORTION→DELAY (serial)

prm1	Distortion Drive	0 - 127
prm2	Distortion Pan	0 - 127
prm3	Delay Time	0 - 126
prm4	Delay Feedback Level	0 - 98
prm5	Delay HF Damp	0 - 17
prm6	Delay Balance	0 - 100
prm7	Output Level	0 - 127

● Type32: ENHANCER→CHORUS (serial)

prm1	Enhancer Sens	0 - 127
prm2	Enhancer Mix Level	0 - 127
prm3	Chorus Pre Delay Time	0 - 125
prm4	Chorus Rate	0 - 125
prm5	Chorus Depth	0 - 127
prm6	(not used)	
prm7	Chorus Balance	0 - 100
prm8	Output Level	0 - 127

● **Type33: ENHANCER→FLANGER (serial)**

prm1	Enhancer Sens	0 - 127
prm2	Enhancer Mix Level	0 - 127
prm3	Flanger Pre Delay Time	0 - 125
prm4	Flanger Rate	0 - 125
prm5	Flanger Depth	0 - 127
prm6	Flanger Feedback Level	0 - 98
prm7	Flanger Balance	0 - 100
prm8	Output Level	0 - 127

● **Type34: ENHANCER→DELAY (serial)**

prm1	Enhancer Sens	0 - 127
prm2	Enhancer Mix Level	0 - 127
prm3	Delay Time	0 - 126
prm4	Delay Feedback Level	0 - 98
prm5	Delay HF Damp	0 - 17
prm6	(not used)	
prm7	Delay Balance	0 - 100
prm8	Output Level	0 - 127

● **Type35: CHORUS→DELAY (serial)**

prm1	Chorus Pre Delay Time	0 - 125
prm2	Chorus Rate	0 - 125
prm3	Chorus Depth	0 - 127
prm4	(not used)	
prm5	Chorus Balance	0 - 100
prm6	Delay Time	0 - 126
prm7	Delay Feedback Level	0 - 98
prm8	Delay HF Damp	0 - 17
prm9	Delay Balance	0 - 100
prm10	Output Level	0 - 127

● **Type36: FLANGER→DELAY (serial)**

prm1	Flanger Pre Delay Time	0 - 125
prm2	Flanger Rate	0 - 125
prm3	Flanger Depth	0 - 127
prm4	Flanger Feedback Level	0 - 98
prm5	Flanger Balance	0 - 100
prm6	Delay Time	0 - 126
prm7	Delay Feedback Level	0 - 98
prm8	Delay HF Damp	0 - 17
prm9	Delay Balance	0 - 100
prm10	Output Level	0 - 127

● **Type37: CHORUS→FLANGER (serial)**

prm1	Chorus Pre Delay Time	0 - 125
prm2	Chorus Rate	0 - 125
prm3	Chorus Depth	0 - 127
prm4	Chorus Balance	0 - 100
prm5	Flanger Pre Delay Time	0 - 125
prm6	Flanger Rate	0 - 125
prm7	Flanger Depth	0 - 127
prm8	Flanger Feedback Level	0 - 98
prm9	Flanger Balance	0 - 100
prm10	Output Level	0 - 127

● **Type38: CHORUS/DELAY (parallel)**

prm1	Chorus Pre Delay Time	0 - 125
prm2	Chorus Rate	0 - 125
prm3	Chorus Depth	0 - 127
prm4	(not used)	
prm5	Chorus Balance	0 - 100
prm6	Delay Time	0 - 126
prm7	Delay Feedback Level	0 - 98
prm8	Delay HF Damp	0 - 17
prm9	Delay Balance	0 - 100
prm10	Output Level	0 - 127

● **Type39: FLANGER/DELAY (parallel)**

prm1	Flanger Pre Delay Time	0 - 125
prm2	Flanger Rate	0 - 125
prm3	Flanger Depth	0 - 127
prm4	Flanger Feedback Level	0 - 98
prm5	Flanger Balance	0 - 100
prm6	Delay Time	0 - 126
prm7	Delay Feedback Level	0 - 98
prm8	Delay HF Damp	0 - 17
prm9	Delay Balance	0 - 100
prm10	Output Level	0 - 127

● **Type40: CHORUS/FLANGER (parallel)**

prm1	Chorus Pre Delay Time	0 - 125
prm2	Chorus Rate	0 - 125
prm3	Chorus Depth	0 - 127
prm4	Chorus Balance	0 - 100
prm5	Flanger Pre Delay Time	0 - 125
prm6	Flanger Rate	0 - 125
prm7	Flanger Depth	0 - 127
prm8	Flanger Feedback Level	0 - 98
prm9	Flanger Balance	0 - 100
prm10	Output Level	0 - 127

MIDI Implementation

■ List of the Arpeggio Parameter

● Arpeggio Style

value	parameter	value	parameter	value	parameter
0	1/ 4	15	RHYTHM GTR A	30	BOUND BOLL
1	1/ 6	16	RHYTHM GTR B	31	RANDOM
2	1/ 8	17	RHYTHM GTR C	32	LIMITLESS
3	1/12	18	RHYTHM GTR D	33	PORTAMENTO A
4	1/16	19	RHYTHM GTR E	34	PORTAMENTO B
5	1/32	20	3 FINGER GTR	35	SEQUENCE D
6	GLISSANDO	21	STRUMMING GTR	36	BOSSA NOVA
7	SEQUENCE A	22	KBD COMPING A	37	SALSA
8	SEQUENCE B	23	KBD COMPING B	38	MAMBO
9	SEQUENCE C	24	KBD COMPING C	39	LATIN PERCUSSION
10	ECHO	25	KBD COMPING D	40	SAMBA
11	SYNTH BASS	26	KBD COMPING E	41	TANGO
12	SLAP BASS A	27	PERCUSSION	42	HOUSE
13	SLAP BASS B	28	HARP		
14	WALK BASS	29	SHAMISEN		

● Arpeggio Motif

value	parameter	value	parameter	value	parameter
0	SINGLE UP	13	BASS+CHORD 3	26	BASS+RANDOM 3
1	SINGLE DOWN	14	BASS+CHORD 4	27	TOP+UP 1
2	SINGLE UP&DOWN	15	BASS+CHORD 5	28	TOP+UP 2
3	SINGLE RANDOM	16	BASS+UP 1	29	TOP+UP 3
4	DUAL UP	17	BASS+UP 2	30	TOP+UP 4
5	DUAL DOWN	18	BASS+UP 3	31	TOP+UP 5
6	DUAL UP&DOWN	19	BASS+UP 4	32	TOP+UP 6
7	DUAL RANDOM	20	BASS+UP 5	33	BASS+UP+TOP
8	NOTE ORDER	21	BASS+UP 6	34	TRIPLE UP
9	GLISSANDO	22	BASS+UP 7	35	TRIPLE DOWN
10	CHORD	23	BASS+UP 8	36	TRIPLE UP&DOWN
11	BASS+CHORD 1	24	BASS+RANDOM 1	37	TRIPLE RANDOM
12	BASS+CHORD 2	25	BASS+RANDOM 2		

● Arpeggio Beat Pattern

value	parameter	value	parameter	value	parameter
0	1/ 4	40	MUTE 15	80	PORTA-B 09
1	1/ 6	41	MUTE 16	81	PORTA-B 10
2	1/ 8	42	STRUM 1	82	PORTA-B 11
3	1/12	43	STRUM 2	83	PORTA-B 12
4	1/16 1	44	STRUM 3	84	PORTA-B 13
5	1/16 2	45	STRUM 4	85	PORTA-B 14
6	1/16 3	46	STRUM 5	86	PORTA-B 15
7	1/32 1	47	STRUM 6	87	SEQ-B 5
8	1/32 2	48	STRUM 7	88	SEQ-D 1
9	1/32 3	49	STRUM 8	89	SEQ-D 2
10	SEQ-A 1	50	REGGAE1	90	SEQ-D 3
11	SEQ-A 2	51	REFRAIN1	91	SEQ-D 4
12	SEQ-A 3	52	REFRAIN2	92	SEQ-D 5
13	SEQ-A 4	53	PERC1	93	SEQ-D 6
14	SEQ-A 5	54	PERC2	94	SEQ-D 7
15	SEQ-A 6	55	PERC3	95	SEQ-D 8
16	SEQ-A 7	56	PERC4	96	REGGAE2
17	SEQ-B 1	57	WALKBS	97	BOSSA NOVA
18	SEQ-B 2	58	HARP	98	SALSA 1
19	SEQ-B 3	59	BOUND	99	SALSA 2
20	SEQ-B 4	60	RANDOM	100	SALSA 3
21	SEQ-C 1	61	PORTA-A 01	101	SALSA 4
22	SEQ-C 2	62	PORTA-A 02	102	MAMBO 1
23	ECHO 1	63	PORTA-A 03	103	MAMBO 2
24	ECHO 2	64	PORTA-A 04	104	CLAVE
25	ECHO 3	65	PORTA-A 05	105	REV CLA
26	MUTE 01	66	PORTA-A 06	106	GUIRO
27	MUTE 02	67	PORTA-A 07	107	AGOGO
28	MUTE 03	68	PORTA-A 08	108	SAMBA
29	MUTE 04	69	PORTA-A 09	109	TANGO 1
30	MUTE 05	70	PORTA-A 10	110	TANGO 2
31	MUTE 06	71	PORTA-A 11	111	TANGO 3
32	MUTE 07	72	PORTA-B 01	112	TANGO 4
33	MUTE 08	73	PORTA-B 02	113	HOUSE 1
34	MUTE 09	74	PORTA-B 03	114	HOUSE 2
35	MUTE 10	75	PORTA-B 04		
36	MUTE 11	76	PORTA-B 05		
37	MUTE 12	77	PORTA-B 06		
38	MUTE 13	78	PORTA-B 07		
39	MUTE 14	79	PORTA-B 08		

Decimal/Hexadecimal Table (hexadecimal values are indicated by a following “H”)

MIDI uses 7-bit hexadecimal values to indicate data values and the address and size of exclusive messages. The following table shows the correspondence between decimal and hexadecimal numbers.

D	H	D	H	D	H	D	H
0	00H	32	20H	64	40H	96	60H
1	01H	33	21H	65	41H	97	61H
2	02H	34	22H	66	42H	98	62H
3	03H	35	23H	67	43H	99	63H
4	04H	36	24H	68	44H	100	64H
5	05H	37	25H	69	45H	101	65H
6	06H	38	26H	70	46H	102	66H
7	07H	39	27H	71	47H	103	67H
8	08H	40	28H	72	48H	104	68H
9	09H	41	29H	73	49H	105	69H
10	0AH	42	2AH	74	4AH	106	6AH
11	0BH	43	2BH	75	4BH	107	6BH
12	0CH	44	2CH	76	4CH	108	6CH
13	0DH	45	2DH	77	4DH	109	6DH
14	0EH	46	2EH	78	4EH	110	6EH
15	0FH	47	2FH	79	4FH	111	6FH
16	10H	48	30H	80	50H	112	70H
17	11H	49	31H	81	51H	113	71H
18	12H	50	32H	82	52H	114	72H
19	13H	51	33H	83	53H	115	73H
20	14H	52	34H	84	54H	116	74H
21	15H	53	35H	85	55H	117	75H
22	16H	54	36H	86	56H	118	76H
23	17H	55	37H	87	57H	119	77H
24	18H	56	38H	88	58H	120	78H
25	19H	57	39H	89	59H	121	79H
26	1AH	58	3AH	90	5AH	122	7AH
27	1BH	59	3BH	91	5BH	123	7BH
28	1CH	60	3CH	92	5CH	124	7CH
29	1DH	61	3DH	93	5DH	125	7DH
30	1EH	62	3EH	94	5EH	126	7EH
31	1FH	63	3FH	95	5FH	127	7FH

D: decimal
H: hexadecimal

- * Decimal expressions such as used for MIDI channel, Bank Select, and Program Change will be the value 1 greater than the decimal value given in the above table.
- * Since each MIDI byte carries 7 significant data bits, each byte can express a maximum of 128 different values. Data for which higher resolution is required must be transmitted using two or more bytes. For example a value indicated as a two-byte value of aa bbH would have a value of $aa \times 128 + bb$.
- * For a signed number (+/-), 00H = -64, 40H = +/-0, and 7FH = +63. I.e., the decimal equivalent will be 64 less than the decimal value given in the above table. For a two-byte signed number, 00 00H = -8192, 40 00H = +/-0, and 7F 7FH = +8191. For example the decimal expression of aa bbH would be $aa \times 128 + bb - 40 \times 128 = (aa \times 128 + bb) - 64 \times 128$.
- * Hexadecimal notation in two 4-bit units is used for data indicated as “nibbled”. The nibbled two-byte value of 0a 0b H would be $a \times 16 + b$.

<Example 1> What is the decimal equivalent of 5AH?

From the above table, 5AH = 90.

<Example 2> What is the decimal equivalent of the 7-bit hexadecimal values 12 34H?

From the above table, 12H = 18 and 34H = 52

Thus, $18 \times 128 + 52 = 2356$

<Example 3> What is the decimal equivalent of the nibbled expression 0A 03 09 0DH?

From the above table, 0AH = 10, 03H = 3, 09H = 9, 0DH = 13

Thus, the result is $((10 \times 16 + 3) \times 16 + 9) \times 16 + 13 = 41885$

<Example 4> What is the nibbled equivalent of the decimal number 1258?

```

16 ) 1258
   ) 78...10
16 ) 4...14
   ) 0...4

```

From the above table, 0=00H, 4=04H, 14=0EH, 10=0AH

Thus the result is 00 04 0E 0AH

Examples of Actual MIDI Messages

<Example 1> 92 3E 5F

9n is the Note On status and ‘n’ is the MIDI channel number. Since 2H = 2, 3EH = 62, and 5FH = 95, this is a Note On message of MIDI CH = 3, note number 62 (note name D4) and velocity 95.

<Example 2> CE 49

CnH is the Program Change status and ‘n’ is the MIDI channel number. Since EH = 14, and 49H = 73, this is a Program Change message of MIDI CH = 15, Program number 74 (in the GS sound map, Flute).

<Example 3> EA 00 28

EnH is the Pitch Bend Change status and ‘n’ is the MIDI channel number. The 2nd byte (00H=0) is the LSB of the Pitch Bend value, and the 3rd byte (28H=40) is the MSB. However since the Pitch Bend is a signed number with 0 at 40 00H ($= 64 \times 128 + 0 = 8192$), the Pitch Bend value in this case is

$$28 \text{ 00H} - 40 \text{ 00H} = 40 \times 128 + 0 - (64 \times 128 + 0) = 5120 - 8192 = -3072$$

If we assume that the Pitch Bend Sensitivity is set to two semitones, the pitch will change only -200 cents for a Pitch Bend value of -8192 (00 00H). Thus, this message is specifying a Pitch Bend of $-200 \times (-3072) / (-8192) = -75$ cents on MIDI CH = 11.

<Example 4> B3 64 00 65 00 06 0C 26 00 64 7F 65 7F

BnH is the Control Change status, and ‘n’ is the MIDI channel number. In Control Change messages, the 2nd byte is the controller number, and the 3rd byte is the parameter value. MIDI allows what is known as “running status,” when if messages of the the same status follow each other, it is permitted to omit the second and following status bytes. In the message above, running status is being used, meaning that the message has the following content.

```

B3 64 00      MIDI CH = 4, RPN parameter number LSB: 00H
(B3) 65 00    MIDI CH = 4, RPN parameter number MSB: 00H
(B3) 06 0C    MIDI CH = 4, parameter value MSB: 0CH
(B3) 26 00    MIDI CH = 4, parameter value LSB: 00H
(B3) 64 7F    MIDI CH = 4, RPN parameter number LSB: 7FH
(B3) 65 7F    MIDI CH = 4, RPN parameter number MSB: 7FH

```

Thus, this message transmits a parameter value of 0C 00H to RPN parameter number 00 00H on MIDI CH = 4, and then sets the RPN parameter number to 7F 7FH.

The function assigned to RPN parameter number 00 00H is Pitch Bend Sensitivity, and the MSB of the parameter value indicates semitone steps. Since the MSB of this parameter value is 0CH = 12, the maximum width of pitch bend is being set to [+]-12 semitones (1 octave) (GS sound sources ignore the LSB of Pitch Bend Sensitivity, but it is best to transmit the LSB (parameter value 0) as well, so that the message can be correctly received by any device.

Once the parameter number has been set for RPN or NRPN, all subsequent Data Entry messages on that channel will be effective. Thus, it is recommended that after you have made the change you want, you set the parameter number to 7F 7FH (an “unset” or “null” setting). The final (B3) 64 7F (B3) 65 7F is for this purpose.

It is not a good idea to store many events within the data of a song (e.g., a Standard MIDI File song) using running status as shown in <Example 4>. When the song is paused, fast-forwarded or rewound, the sequencer may not be able to transmit the proper status, causing the sound source to misinterpret the data. It is best to attach the proper status byte to all events.

It is also important to transmit RPN or NRPN parameter number settings and parameter values in the correct order. In some sequencers, data events recorded in the same clock (or a nearby clock) can sometimes be transmitted in an order other than the order in which they were recorded. It is best to record such events at an appropriate interval (1 tick at TPQN=96, or 5 ticks at TPQN=480).

* TPQN: Ticks Per Quarter Note (i.e., the time resolution of the sequencer)

MIDI Implementation

Examples of Exclusive Messages and Calculating the Checksum

Roland exclusive messages (RQ1, DT1) are transmitted with a checksum at the end of the data (before F7) to check that the data was received correctly. The value of the checksum is determined by the address and data (or size) of the exclusive message.

How to Calculate the Checksum (hexadecimal values are indicated by a "H")

The checksum consists of a value whose lower 7 bits are 0 when the address, size and checksum itself are added.

The following formula shows how to calculate the checksum when the exclusive message to be transmitted has an address of aa bb cc ddH, and data or size of ee ffH.

$$aa + bb + cc + dd + ee + ff = \text{total}$$

$$\text{total} / 128 = \text{quotient} \dots \text{remainder}$$

$$128 - \text{remainder} = \text{checksum}$$

Example 1> Setting the Performance Common REVERB TYPE to DELAY (DT1)

The "Parameter address map" indicates that the starting address of the Temporary Performance is 01 00 00 00H, that the Performance Common offset address is 00 00H, and that the REVERB TYPE address is 00 28H. Thus, the address is:

$$\begin{array}{r} 01\ 00\ 00\ 00\text{H} \\ \quad \quad 00\ 00\text{H} \\ +) \quad \quad 00\ 28\text{H} \\ \hline 01\ 00\ 00\ 28\text{H} \end{array}$$

Since DELAY is parameter value 06H,

F0	41	10	6A	12	01 00 00 28	06	??	F7
(1)	(2)	(3)	(4)	(5)	address	data	checksum	(6)

- (1) Exclusive status
- (2) ID number (Roland)
- (3) Device ID (17)
- (4) Model ID (XP-30)
- (5) Command ID (DT1)
- (6) EOX

Next we calculate the checksum.

$$01\text{H} + 00\text{H} + 00\text{H} + 28\text{H} + 06\text{H} = 1 + 0 + 0 + 40 + 6 = 47 \text{ (sum)}$$

$$47 \text{ (total)} / 128 = 0 \text{ (quotient)} \dots 47 \text{ (remainder)}$$

$$\text{checksum} = 128 - 47 \text{ (quotient)} = 81 = 51\text{H}$$

This means that the message transmitted will be F0 41 10 6A 12 01 00 00 28 06 51 F7.

Example 2> Retrieving data for USER:03 Performance Part 3 (RQ1)

The "Parameter Address Map" indicates that the starting address of USER:03 is 10 02 00 00H, and that the offset address of Performance Part 3 is 12 00H. Thus, the address is:

$$\begin{array}{r} 10\ 02\ 00\ 00\text{H} \\ \quad \quad 12\ 00\text{H} \\ +) \quad \quad 00\ 00\text{H} \\ \hline 10\ 02\ 12\ 00\text{H} \end{array}$$

Since the size of the Performance Part is 00 00 00 19H,

F0	41	10	6A	11	10 02 12 00	00 00 00 19	??	F7
(1)	(2)	(3)	(4)	(5)	address	size	checksum	(6)

- (1) Exclusive status
- (2) ID number (Roland)
- (3) Device ID (17)
- (4) Model ID (XP-30)
- (5) Command ID (RQ1)
- (6) EOX

Next we calculate the checksum.

$$10\text{H} + 02\text{H} + 12\text{H} + 00\text{H} + 00\text{H} + 00\text{H} + 00\text{H} + 19\text{H} =$$

$$16 + 2 + 18 + 0 + 0 + 0 + 0 + 25 = 61 \text{ (sum)}$$

$$61 \text{ (total)} / 128 = 0 \text{ (product)} \dots 61 \text{ (remainder)}$$

$$\text{checksum} = 128 - 61 \text{ (remainder)} = 67 = 43\text{H}$$

Thus, a message of F0 41 10 6A 11 10 02 12 00 00 00 00 19 43 F7 would be transmitted.

Example 3> Retrieving data for Temporary Performance (RQ1)

* When a data transfer is executed in Utility mode, data that is accessed will be the same as that which is transmitted when the Type parameter is set to PERFORM and the Source parameter is set to TEMP: -PATCH

The "Parameter Address Map" gives the following start addresses for Temporary Performance data.

01 00 00 00H	Temporary Performance Common
01 00 10 00H	Temporary Performance Part 1
:	
01 00 1F 00H	Temporary Performance Part 16

Since Performance Part has a size of 00 00 00 19H, we add that size to the start address of the Temporary Performance Part 16, resulting in:

$$\begin{array}{r} 01\ 00\ 1F\ 00\text{H} \\ +) 00\ 00\ 00\ 19\text{H} \\ \hline 01\ 00\ 1F\ 19\text{H} \end{array}$$

Thus, the Size for the retrieved data will be:

$$\begin{array}{r} 01\ 00\ 1F\ 19\text{H} \\ -) 01\ 00\ 00\ 00\text{H} \\ \hline 00\ 00\ 1F\ 19\text{H} \end{array}$$

F0	41	10	6A	11	01 00 00 00	00 00 1F 19	??	F7
(1)	(2)	(3)	(4)	(5)	address	size	checksum	(6)

- (1) Exclusive status
- (2) ID number (Roland)
- (3) Device ID (17)
- (4) Model ID (XP-30)
- (5) Command ID (RQ1)
- (6) EOX

Calculating the checksum as shown in <Example 2>, we get a message of F0 41 10 6A 11 01 00 00 00 00 1F 19 47 F7 to be transmitted.

Example 4> Retrieving the Temporary Performance data together with all Temporary Part and Rhythm Set data (RQ1)

* When a data transfer is executed in Utility mode, the data that is accessed will be the same as that which is transmitted when the Type parameter is set to PERFORM and the Source parameter is set to TEMP: +PATCH

The "Parameter Address Map" gives the following start addresses for Temporary Performance, Performance Mode Temporary Patch and Performance Mode Temporary Rhythm.

01 00 00 00H	Temporary Performance
02 00 00 00H	Performance Mode Temporary Patch(part 1)
:	
02 08 00 00H	Performance Mode Temporary Patch(part 9)
02 09 00 00H	Temporary Rhythm Setup
02 0A 00 00H	Performance Mode Temporary Patch(part 11)
:	
02 0F 00 00H	Performance Mode Temporary Patch(part 16)

The Patch offset addresses are as follows.

00 00H	Patch Common
10 00H	Patch Tone 1
:	
16 00H	Patch Tone 4

Since Patch Tone has a size of 00 00 01 01H, we add this size to the start address of Performance Mode Temporary Patch (Part 16) Tone 4, to get:

$$\begin{array}{r} 02\ 0F\ 00\ 00\text{H} \\ \quad \quad 16\ 00\text{H} \\ +) 00\ 00\ 01\ 01\text{H} \\ \hline 02\ 0F\ 17\ 01\text{H} \end{array}$$

Thus, the size of the retrieved data will be:

$$\begin{array}{r} 02\ 0F\ 17\ 01\text{H} \\ -) 01\ 00\ 00\ 00\text{H} \\ \hline 01\ 0F\ 17\ 01\text{H} \end{array}$$

F0	41	10	6A	11	01 00 00 00	01 0F 17 01	??	F7
(1)	(2)	(3)	(4)	(5)	address	size	checksum	(6)

- (1) Exclusive status
- (2) ID number (Roland)
- (3) Device ID (17)
- (4) Model ID (XP-30)
- (5) Command ID (RQ1)
- (6) EOX

Calculating the checksum as shown in <Example 2>, we get a message of F0 41 10 6A 11 01 00 00 00 01 0F 17 01 57 F7 to be transmitted.

■ Scale Tune Function

(Model ID : 42H (GS), address: 40 1x 40H)

Scale Tune is a function that makes fine adjustments to the pitch of each note C-B. Settings are made for one octave, and applied to the notes of all octaves. By making Scale Tune settings you can use tunings and temperaments other than the standard Equal Temperament. Here we give three types of settings as examples.

* Scale tune messages for any parts are recognized in the patch mode.

○Equal Temperament

This temperament divides the octave into 12 equal steps, and is the temperament most frequently used today, especially in western music. Initially, the Scale Tune function of this instrument is set to Equal Temperament.

○Just Intonation (tonic of C)

The primary triads sound more beautiful in just intonation than in equal temperament. However, this applies only in one key, and chords will be discordant if you play in a different key. The settings here are for a tonic of C.

○Arabian-type Scale

The Scale Tune function allow you to use various tunings of ethnic music. Here is one of the Arabian scales.

Setting Examples

Note	Equal Temp.	Just (in C)	Arabian-type Scale
C	0	0	-6
C#	0	-8	+45
D	0	+4	-2
Eb	0	+16	-12
E	0	-14	-51
F	0	-2	-8
F#	0	-10	+43
G	0	+2	-4
G#	0	+14	+47
A	0	-16	0
Bb	0	+14	-10
B	0	-12	-49

The values in the above table are in units of 1 cent. Convert these values to hexadecimal, and transmit them as exclusive data. For example to set the Scale Tune of Part 1 to an Arabian-type scale, transmit the following data.

F0 41 10 42 12 40 11 40 3A 6D 3E 34 0D 38 6B 3C 6F 40 36 0F 76 F7

■ ASCII Code Table

On the XP-30, the following ASCII code set is used for processing data such as the Patch Name and the Performance Name.

D	H	Char	D	H	Char	D	H	Char
32	20H	SP	64	40H	@	96	60H	`
33	21H	!	65	41H	A	97	61H	a
34	22H	"	66	42H	B	98	62H	b
35	23H	#	67	43H	C	99	63H	c
36	24H	\$	68	44H	D	100	64H	d
37	25H	%	69	45H	E	101	65H	e
38	26H	&	70	46H	F	102	66H	f
39	27H	^	71	47H	G	103	67H	g
40	28H	(72	48H	H	104	68H	h
41	29H)	73	49H	I	105	69H	i
42	2AH	*	74	4AH	J	106	6AH	j
43	2BH	+	75	4BH	K	107	6BH	k
44	2CH	,	76	4CH	L	108	6CH	l
45	2DH	-	77	4DH	M	109	6DH	m
46	2EH	.	78	4EH	N	110	6EH	n
47	2FH	/	79	4FH	O	111	6FH	o
48	30H	0	80	50H	P	112	70H	p
49	31H	1	81	51H	Q	113	71H	q
50	32H	2	82	52H	R	114	72H	r
51	33H	3	83	53H	S	115	73H	s
52	34H	4	84	54H	T	116	74H	t
53	35H	5	85	55H	U	117	75H	u
54	36H	6	86	56H	V	118	76H	v
55	37H	7	87	57H	W	119	77H	w
56	38H	8	88	58H	X	120	78H	x
57	39H	9	89	59H	Y	121	79H	y
58	3AH	:	90	5AH	Z	122	7AH	z
59	3BH	;	91	5BH	[123	7BH	{
60	3CH	<	92	5CH	\	124	7CH	}
61	3DH	=	93	5DH]	125	7DH	~
62	3EH	>	94	5EH	^			
63	3FH	?	95	5FH	_			

D: decimal

H: hexadecimal

Note: SP indicates "space".

Specifications

XP-30: 64 Voice Expandable Synthesizer (Conforms to General MIDI System)

● Keyboard

61 keys (with velocity, channel aftertouch)

● Number of Parts

16 (Part 10 is Rhythm Part)

● Maximum Polyphony

64 voices

● Effects

EFX: 40 sets

Reverb: 1 set (8 types)

Chorus: 1 set

● Preset Memory

Patches: 1406 (640 same as the JV-2080 + 766 from "Session," "Orchestral" and "Techno Collection")

Performances: 64

Rhythm Sets: 26 (10 same as the JV-2080 + 16 from "Session" and "Techno Collection")

● User Memory

Patches: 128

Performances: 32

Rhythm Sets: 2

● Wave Expansion Boards (sold separately)

Max. 2 Boards (D, E)

* Each Wave Expansion Board includes Patches / Rhythm Sets that make use of the waves on the board.

● Arpeggiator

43 Styles

● Display

40 characters, 2 lines (backlit LCD)

● Connectors

Output Jacks (L (MONO), R)

Headphones Jack

MIDI Connectors (IN, OUT, THRU)

Computer Connector (Mac, PC-1, PC-2, MIDI)

Hold Pedal Jack

Control Pedal Jack

Memory Card Slot

● Power Supply

AC 117 V, AC 230 V, AC 240 V

● Power Consumption

10 W (AC 117 V), 10 W (AC 230 V), 10 W (AC 240 V)

● Dimensions

1011 (W) x 289 (D) x 88 (H) mm

39-13/16 (W) x 11-7/16 (D) x 3-1/2 (H) inches

● Weight

7.8 kg / 17 lbs 4 oz (except Power cord)

● Accessories

Owner's Manual

Power Cable (Not included with XP-30 designed for 117 V power supply)

CD-ROM (SoundDiver JV/XP)

● Options

Wave Expansion Boards: SR-JV80 series

SmartMedia: S2M-5 (2M bytes), S4M-5 (4M bytes)

**In the interest of product improvement, the specifications and/or appearance of this unit are subject to change without prior notice.*

Computer Cable Wiring Diagrams

For Apple Macintosh (Sold separately: RSC-15APL)

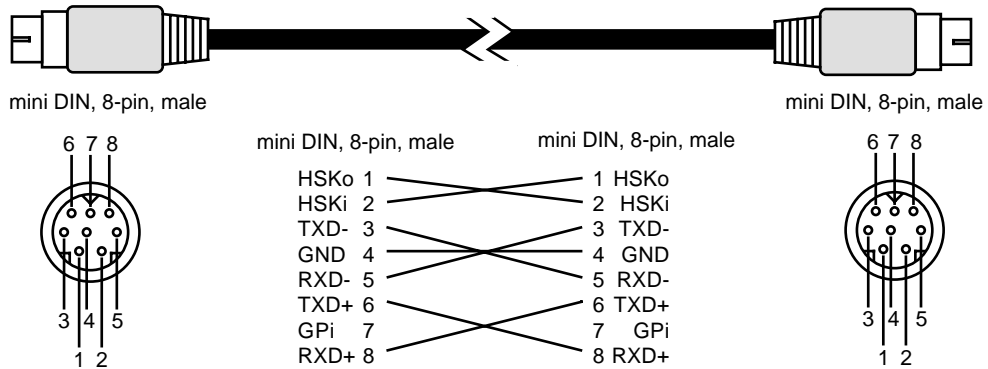

For PC (9-pin) (Sold separately: RSC-15AT)

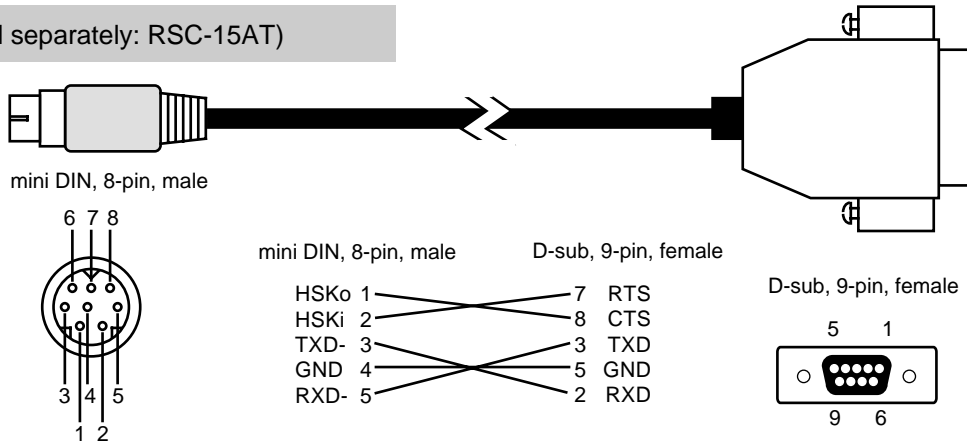

For PC (25-pin)

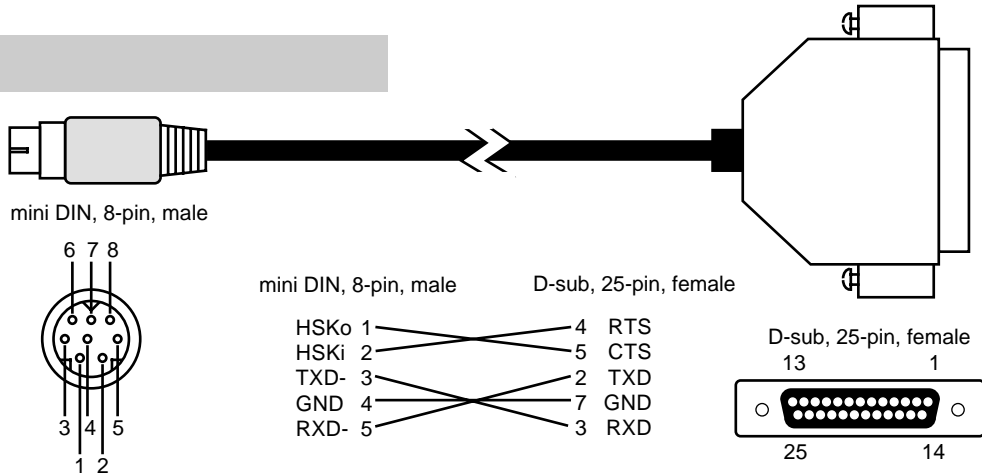

Index

Symbols

[+OCT] 12, 59
[-OCT] 12, 59

Numerics

[1–8/9–16] 13
2VOICE-PITCH-SHIFTER 102

A

AC inlet 14
AC power cable 25
Accent rate 109
Aftertouch 34
Aftertouch control source 111
Aftertouch information 87, 127
Aftertouch sens 110
Alternate pan depth 82, 92
Analog feel depth 69
Arabian scale 114
ARP SELECT display 37, 56
Arpeggiator 36, 56
[ARPEGGIO] 12, 36, 56
Arpeggio 36, 108
arpeggio 56
ARPEGGIO display 59
Arpeggio part 110
Arpeggio style 182
Audio cable 25
AUTO-WAH 95

B

Back select transmit switch 113
Bank select group number 113
Bank select LSB 113
Bank select MSB 113
Battery check 114
Beat pattern 109
Bend range 73, 90
Bender information 87
Bias direction 82
Bias level 82
Bias point 82
Booster gain 71
Breath information 87, 127
Bulk dump 119

C

C1/C2/C3/C4 slider assign 111
C1/C2/C3/C4 slider output 111
C1–C4 slider 34
Card 115
[CATEGORY] 13, 32, 48
Category 32, 48–49
Category group 32
Category select mode 108
Chorus 61
Chorus depth 72, 85, 89, 126
Chorus feedback level 72, 85, 89, 126
Chorus level 72, 85, 89, 126
Chorus output assign 72, 85, 89, 126
Chorus pre delay 72, 85, 89, 126
Chorus rate 72, 85, 89, 126
Chorus send level 71–72, 84, 88, 125
CHORUS/DELAY 107
CHORUS/FLANGER 107
CHORUS→DELAY 106
CHORUS→FLANGER 107
Clock source 108
Coarse tune 79, 87, 91, 127
Compare function 116, 118
COMPRESSOR 96
Computer 134
Computer cable 134, 208
COMPUTER connector 14, 135
COMPUTER switch 14, 134–135
Connection 24, 134
Control 1 peak/hold 75
Control 2 peak/hold 75
Control 3 peak/hold 75
CONTROL PEDAL jack 14
Control source 2 75
Control source 3 75
[CONTROLLER] 12, 34
Controller 40
Copy 115
Copying 117, 128
Current part 53
Cursor 45
Cursor button 13, 44
Cutoff frequency 80, 91
Cutoff frequency key follow 80

D

Data transfer 115
 Data type 120
 [DEC] 13, 45
 Delay feedback level 73, 86, 90, 126
 [DEMO] 13
 Demo play 28
 DEMO PLAY display 28
 Demo song 28
 Depth 1–4 75
 Desktop music 134
 Destination 120–121
 Destination 1–4 75
 [DIGIT HOLD] 13
 Digit hold 48
 DISTORTION 93
 DISTORTION→CHORUS 104
 DISTORTION→DELAY 105
 DISTORTION→FLANGER 105

E

[EDIT] 13
 Effects 61
 [EFFECTS ON/OFF] 12, 62
 EFFECTS ON/OFF display 62
 EFX control depth 1, 2 72, 85, 89
 EFX control peak/hold 75
 EFX control source 1, 2 72, 85, 89
 EFX output level 72, 84, 88, 125
 EFX parameter 93, 154
 EFX source 84, 88
 EFX type 71, 84, 88
 ENHANCER 94
 ENHANCER→CHORUS 105
 ENHANCER→DELAY 106
 ENHANCER→FLANGER 105
 [ENTER] 13
 Envelope mode 90
 Equal temperament 114
 Error message 142
 Exclusive device ID number 113
 Exclusive protect 121
 [EXIT] 13
 [EXP A] 13, 31
 [EXP B] 13, 31
 [EXP C] 13, 31
 [EXP D] 13, 31
 [EXP E] 13, 31
 Expression information 87, 127
 Expression pedal 25, 35
 External MIDI device 131–132

F

Factory default settings 123
 Factory reset 27, 115, 123
 FACTORY RESET display 27
 FBK-PITCH-SHIFTER 102
 Filter type 80, 91
 [FILTER/ENV] 12, 36, 51, 54
 Fine tune 79, 87, 91, 127
 FLANGER/DELAY 107
 FLANGER→DELAY 106
 Foot information 87, 127
 Format 122
 Front panel 12
 Function button 13, 43
 FXM color 76
 FXM depth 76
 FXM switch 76

G

GATE-REVERB 103
 General MIDI system 11
 [GM] 12
 GM initialize 128
 GM mode 43, 124
 GM mode parameter 153
 GM patch number 127
 GM PLAY display 124
 GM score data 124
 GM sound module 124
 GM system on message 124

H

Headphones 25
 HEXA-CHORUS 96
 Hold 1 information 87, 127
 Hold control source 111
 Hold pedal 35, 58
 HOLD PEDAL jack 14

I

[INC] 13, 45
 Initial data 119
 Initialize 115
 Initialize mode 119
 Initializing 119, 128
 Internal write protect 68, 116, 121

K

Key assign mode	73
KEY EFFECTS section	12
Key mode	83
Key range lower	70, 83
Key range switch	83
Key range upper	70, 83
Key scale	114
Key shift	113
Key switch	90
Key velocity	109
Keyboard sensitivity	110
Keyboard velocity	110

L

Layer	52
Layer performance	51
LCD contrast	108
[LEVEL]	12, 36, 51, 54
Level	68, 81, 87, 92
LFO	78
LFO delay time	79
LFO external sync	78
LFO fade mode	78
LFO fade time	79
LFO form	78
LFO key sync	78
LFO offset	79
LFO rate	78
LIMITER	96
Load	115
Local OFF	137
Local switch	86, 112
Looped	64

M

Master tune	113
Memory	67, 115
Memory card	67, 115, 121
MEMORY CARD slot	14
MIDI	112
MIDI cable	25
MIDI channel	86
MIDI connectors (IN, OUT, THRU)	14
MIDI information	127
MIDI interface	135
MODE section	12
Modulation	34
Modulation information	87, 127
MODULATION-DELAY	99
Motif	109
Multi-effects	61, 93
Multitimbral sound source	41, 53
Mute group	90

N

Name	46
Number of simultaneous voices	42
Numeric Key	13, 45

O

Octave range	109
Octave shift	59, 69, 83
One-shot	64
Operating environment	108
Orchestral	31, 47
Output assign/Output level	71, 84, 88, 125
OUTPUT jacks (L (MONO), R)	14
OVERDRIVE	93
OVERDRIVE→DELAY	104
OVERDRIVE→FLANGER	104

P

Page button	13
Palette display	63, 65
[PALETTE EDIT]	13, 63, 65
PALETTE section	12
Pan	69, 81, 87, 92, 127
Pan information	87, 127
Pan key follow	82
Pan LFO depth 1, 2	79
[PANIC]	13
Panic	60
Parameter	147
[PART]	12
Part	41
Part button	43
[PATCH]	12, 30, 47
Patch	30, 41, 47, 168
Patch category	68
Patch clock source	68
Patch copy	117
Patch effects copy	117
Patch group	87
Patch initialize	119
Patch mode	42, 47
Patch mode receive channel	112
Patch mode transmit channel	112
Patch name	68
Patch name copy	118
Patch number	87
Patch parameter	68, 147
PATCH PLAY display	30, 47
Patch remain switch	108
Patch scale	114
Patch search function	32, 48
Patch tempo	68
Patch tone copy	117
Patch write	116
Peak control source	111
Pedal assign	110
Pedal output	110
Pedal polarity	110-111

Pedal switch 25, 131
 [PERFORM] 12, 51
 PERFORM NAME 83
 PERFORM PLAY display 51
 Performance 41, 51, 181
 Performance clock source 83
 Performance control channel 112
 Performance copy 117
 Performance effects copy 117
 Performance initialize 119
 Performance mode 42, 51
 Performance name 83
 Performance name copy 117
 Performance parameter 83, 150
 Performance part copy 117
 Performance tempo 83
 Performance write 116
 PHASER 94
 PHONES jack 14
 [PHRASE PREVIEW] 12, 33, 49
 Phrase preview 33, 49, 113
 Pitch bend 34
 Pitch bend information 127
 Pitch bend/Modulation lever 13, 34
 Pitch envelope depth 79, 91
 Pitch envelope level 1–4 80, 91
 Pitch envelope time 1 velocity sensitivity 80
 Pitch envelope time 1–4 80, 91
 Pitch envelope time 4 velocity sensitivity 80
 Pitch envelope time key follow 80
 Pitch envelope time velocity sensitivity 91
 Pitch envelope velocity sensitivity 80, 91
 Pitch key follow 79
 Pitch LFO depth 1, 2 79
 [PORTAMENTO] 12, 35, 50
 Portamento 35, 50
 Portamento mode 73
 Portamento start pitch 74
 Portamento switch 73
 Portamento time 73
 Portamento type 73
 Power switch 14, 26
 Power up mode 108
 Preset memory 67
 Preview note set 1–4 113
 PREVIEW SELECT display 49
 Preview sound mode 49, 113
 Preview velocity 113
 Program change 114
 Pure temperament 114

Q

QUADRUPLE-TAP-DELAY 101

R

Random pan depth 82, 92
 Random pitch depth 79, 91
 Rear panel 14
 Receive bank select switch 112
 Receive exclusive switch 113
 Receive GM exclusive switch 113
 Receive hold 1 switch 74, 86, 90
 Receive pan control switch 74, 90
 Receive pitch bend switch 74
 Receive program change switch 86, 112
 Receive switch 86, 90
 Receive volume switch 74, 86, 90
 Redamper switch 74
 Remote keyboard switch 112
 Resonance 80, 91
 Resonance velocity sensitivity 81, 92
 REVERB 103
 Reverb 61
 Reverb send level 71–72, 84, 88, 125–126
 Reverb/Delay HF damp 73, 86, 90, 126
 Reverb/Delay level 73, 86, 90, 126
 Reverb/Delay time 73, 85, 89, 126
 Reverb/Delay type 73, 85, 89, 126
 [RHYTHM] 12, 38, 55
 Rhythm key copy 118
 RHYTHM PLAY display 38, 55
 Rhythm set 38, 41, 55, 177
 Rhythm set copy 118
 Rhythm set initialize 119
 Rhythm set mode 42, 55
 Rhythm set name 88
 Rhythm set name copy 118
 Rhythm set parameter 88, 151
 Rhythm set write 116
 Ring modulator 71
 ROTARY 95

S

Save	115
Scale tune switch	113
Session	31, 47, 55
[SHIFT]	13
Shuffle rate	109
Single performance	51
Slots EXP-D and E	16, 114
SmartMedia	67
[SOLO]	12, 35, 50
Solo	35, 50
Solo legato switch	73
Sound palette	36
Sound palette function	50, 54
Sound source	40, 42
Source block	120–121
SPACE-D	97
SPECTRUM	94
Split	52
SR-JV80 series	16, 67
STEP-FLANGER	98
STEREO-CHORUS	97
STEREO-DELAY	99
STEREO-EQ	93
STEREO-FLANGER	98
Storing	116
Stretch tuning depth	69
Stretched tuning	69
Structure	70
Structure type	70
Style	108
[SYSTEM]	12
System control assign 1/2	111
System controller 1 information	87
System controller 2 information	87
System memory	67
System mode	43
System parameter	108, 158
System tempo	108

T

Techno	47
Techno Collection	31, 47, 55
Tempo	110
Temporary area	67
Thru function	137
TIME-CONTROL-DELAY	101
Tone	40, 50
Tone delay mode	76
Tone delay time	77
[TONE SELECT]	44
Tone select button	44
[TONE SWITCH]	44
Tone switch	76
Tone switch button	44
Transmit active sensing switch	113
Transmit bank select group	86
Transmit bank select LSB	114
Transmit bank select MSB	114
Transmit bank select switch	112
Transmit edit data switch	113
Transmit MIDI channel	114
Transmit program change	114
Transmit program change switch	112
Transmit switch	86
Transmit volume	87
Transmitting	119, 128
[TRANPOSE]	12, 60
Transpose	60
Transpose switch/value	110
TREMOLO-CHORUS	97
TRIPLE-TAP-DELAY	100
Tuning	113
TVA	81, 92
TVA envelope 1–3	82
TVA envelope 1–4	82
TVA envelope level 1–3	92
TVA envelope time 1–4	92
TVA envelope time 4 velocity sensitivity	82
TVA envelope time key follow	82
TVA envelope time velocity sensitivity	92
TVA envelope velocity curve	81
TVA envelope velocity sensitivity	81, 92
TVA LFO depth 1, 2	79
TVF	80, 91
TVF envelope depth	80, 91
TVF envelope level 1–4	81, 92
TVF envelope time 1 velocity sensitivity	81–82
TVF envelope time 1–4	81, 92
TVF envelope time 4 velocity sensitivity	81
TVF envelope time key follow	81
TVF envelope time velocity sensitivity	92
TVF envelope velocity curve	81
TVF envelope velocity sensitivity	81, 92
TVF LFO depth 1, 2	79

U

Undo	45
[UNDO/COMPARE]	13, 45, 116, 118
User memory	67–68, 116
User memory protect	115
UTIL 1 display	27, 68
UTIL 2 display	27
[UTIL/CARD]	12, 27, 68, 115
Utility/Card mode	43, 115

V

VALUE dial	13, 45
Velocity	34
Velocity cross fade	69
Velocity range lower	69
Velocity range switch	69
Velocity range upper	69
Voice information	87, 127
Voice priority	69
Voice reserve	42, 87
Volume	127
Volume control source	111
Volume information	87, 127
VOLUME slider	26
Volume slider	12

W

Wave	47
Wave expansion board	16, 47, 55, 67, 114
WAVE EXPANSION section	13
Wave gain	76, 90
Wave group	76, 90
Wave number	76, 90
Waveform	160
Write	115
WRITE display	68

For EU Countries

Apparatus containing Lithium batteries

ADVARSEL!

Lithiumbatteri - Eksplosionsfare ved fejlagtig håndtering.
Udskiftning må kun ske med batteri af samme fabrikat og type.
Levér det brugte batteri tilbage til leverandøren.

ADVARSEL

Eksplosjonsfare ved feilaktig skifte av batteri.
Benytt samme batteritype eller en tilsvarende type anbefalt av apparatfabrikanten.
Brukte batterier kasseres i henhold til fabrikantens instruksjoner.

CAUTION

Danger of explosion if battery is incorrectly replaced.
Replace only with the same or equivalent type recommended by the manufacturer.
Discard used batteries according to the manufacturer's instructions.

VARNING

Explosionsfara vid felaktigt batteribyte.
Använd samma batterityp eller en ekvivalent typ som rekommenderas av apparattillverkaren.
Kassera använt batteri enligt fabrikantens instruktion.

VAROITUS

Paristo voi räjähtää, jos se on virheellisesti asennettu.
Vaihda paristo ainoastaan laitevalmistajan suosittelemaan tyyppiin. Hävitä käytetty paristo valmistajan ohjeiden mukaisesti.

For EU Countries



This product complies with the requirements of European Directives EMC 89/336/EEC and LVD 73/23/EEC.

For the USA

FEDERAL COMMUNICATIONS COMMISSION RADIO FREQUENCY INTERFERENCE STATEMENT

This equipment has been tested and found to comply with the limits for a Class B digital device, pursuant to Part 15 of the FCC Rules. These limits are designed to provide reasonable protection against harmful interference in a residential installation. This equipment generates, uses, and can radiate radio frequency energy and, if not installed and used in accordance with the instructions, may cause harmful interference to radio communications. However, there is no guarantee that interference will not occur in a particular installation. If this equipment does cause harmful interference to radio or television reception, which can be determined by turning the equipment off and on, the user is encouraged to try to correct the interference by one or more of the following measures:

- Reorient or relocate the receiving antenna.
- Increase the separation between the equipment and receiver.
- Connect the equipment into an outlet on a circuit different from that to which the receiver is connected.
- Consult the dealer or an experienced radio/TV technician for help.

Unauthorized changes or modification to this system can void the users authority to operate this equipment.
This equipment requires shielded interface cables in order to meet FCC class B Limit.

For Canada

NOTICE

This Class B digital apparatus meets all requirements of the Canadian Interference-Causing Equipment Regulations.

AVIS

Cet appareil numérique de la classe B respecte toutes les exigences du Règlement sur le matériel brouilleur du Canada.

AFRICA

EUROPE

AUSTRALIA/
NEW ZEALAND

ASIA

CENTRAL/LATIN
AMERICA

NORTH AMERICA

MIDDLE EAST

II

II